

3810 in-furrow TM

P

R



JOHN DEERE

PARTS CATALOG

3810 in-furrow TM

F

PC12336 (Feb-16) English

Revision 06/2017

P

R

O

O

South Africa Portfolio Extension Group

South Africa Edition
Printed in U.S.A. (Revised)
COPYRIGHT © 2016
DEERE & COMPANY
Moline, Illinois
All rights reserved

P R O O F P R O O F

Introduction and Product Information

NP27017 A.1



NP27017

John Deere 3810 in-furrow / on-land Plow
(Manufactured 2014 -)

(Specifications and Design Subject to Change Without Notice.)

To The Customer

The part numbers in this Parts Catalog were correct at the time of publication. Per John Deere policy, we continuously improve our products. Therefore, when ordering parts verify the part numbers with your dealer.

SI Units of Measure

Metric dimensions are provided as applicable throughout this parts catalog.

Bolt And Cap Screw Strength Identification

Bolts and cap screws required to have high-strength qualities equivalent to metric property class 10.9 (SAE grade 8) or higher are identified throughout this catalog by the description 10.9, 12.9 or 14.9. All standard bolts and cap screws are metric property class 8.8 (SAE grade 5) or lower.

Box-Enclosed Illustration

Box-enclosed keyed parts in the illustration are available as a service assembly or an attachment. These assemblies may also include parts not available for service separately. The illustrations may not show all individual parts of an attachment. A box not keyed includes non-current parts.

Direction Arrow

Arrows are used with illustrations to indicate the front of the unit. "Right-Hand" and "Left-Hand" sides are determined by facing in direction of machine forward travel.

Orientation Of Product

An arrow shown with an illustration is to indicate the direction of product forward travel. Right Hand (RH) and Left Hand (LH) sides are determined by product forward travel.

Ag and Turf Crop Solution — Trademarks

AccuDepth™	Quick Fill™	STS™
AutoTrac™	Refuge Ready™	TouchSet™
BoomTrac™	Row-Trak™	Nothing Runs Like a Deere™
CCS™	RowCommand™	Tru-Depth™
FieldVision™	SeedStar™	TruPosition™
Flex-Fold™	CommandARM™	TwinFluid GreenStar™
CommandCenter™	VacuMeter™	Hi-Cycle™
John Deere™	VRS™ (VariRow System)	HillMaster™
Level-lift™	Funk™	PRO-12™
Load Command™	iTorque™	PRO-16™
MaxEmerge™	Phoenix™	ProDrive™
Maximizer™	PowerTech™	PRO-SERIES™
Service ADVISOR™	TMII™	Pro-Series XP™
SprayMaster™	TMIII™	Pro-Shaft™
StarFire™		

P
R
O
F
E
S
S
I
O
N
A
L

Ag and Turf Crop Solution — Terms and Abbreviations

Phrase	Meaning	Phrase	Meaning
A/C	Air Conditioning	NLA	No Longer Available
ALSO ORDER	Also Order	NSEP	Not Supplied Separately
APPL	This Application Only	OD	Outside Diameter
AR	As Required	OPTION	Option
ASSY	Complete Assembly	OPTIONAL	Optional
BCU	Basic Control Unit	OR	Or
CNLA	Complete No Longer Available (Order Individual Parts)	ORD	Order
ECU	Engine Control Unit	ORD W/	Order With
ETC	Electronic Temperature Control	OS	Oversize
FI	Field Installation Kit	PKG	Package of
FIP	Fuel Injection Pump	RATIO	Ratio
FOR	For	RCU	Reverser Control Unit
FRONT	Front	REAR	Rear
GSD	GreenStar™ Display	REMAN	Remanufactured
HTC	Heater Control Unit	RH	Right Hand
ID	Inside Diameter	STD	Standard
INCL	Includes	SUB	Replaced by
INCL KEYS	Including Keys	SUB FOR	Substitute for
JDL	JDLink™ Control Unit	TK	Thickness
KIT	Kit	UIC	User Interface Control Unit
LGTH	Length	UIM	User Interface Module
LH	Left Hand	UP	Upper
LOW	Lower	USE WITH	Use With
MARKED	Marked	W/	With
MF	Make From	W/O	Without
NA	Not Applicable	Z	Gear and Sprocket Teeth Number
L	Number of Links to Chain		

Введение и информация об изделии

NP27017 A.1



NP27017

Плуг для работы в борозде / вне борозды 3810 компании John Deere
(Год выпуска 2014–)

(Спецификации и конструкция могут изменяться без уведомления.)

Уведомление для заказчика

Номера деталей в этом каталоге запасных частей верны на момент его публикации. Политика компании John Deere заключается в непрерывном совершенствовании выпускаемых продуктов. Поэтому при заказе запасных частей проверяйте их номера по каталогу у своего дилера.

Единицы измерения по системе СИ

В этом каталоге запасных частей размеры даны в метрических единицах измерения по мере применимости.

Определение прочности болтов и винтов с головками

Для болтов и винтов с головками, имеющих высокий класс прочности, эквивалентный категории изделия 10.9 в метрических единицах (SAE 8) или выше, в этом каталоге приняты обозначения 10.9, 12.9 или 14.9. Все стандартные болты и винты с головками относятся к категории изделия 8.8 в метрических единицах (SAE 5) или ниже.

Иллюстрация, заключенная в рамку

Детали, снабженные кодом и заключенные в рамку на иллюстрации, доступны в качестве обслуживаемого узла либо навесного оборудования. В состав этих деталей могут также входить необслуживаемые детали. Полнота перечня отдельных комплектующих деталей навесного оборудования, представленного на иллюстрациях, не гарантируется. В рамке без кода указаны устаревшие детали.

Стрелка направления

На иллюстрациях стрелками обозначена передняя часть блока. Левую и правую стороны определяют по направлению переднего хода машины.

Ориентация машины

Стрелка на иллюстрации служит для обозначения направления переднего хода машины. Левую и правую стороны определяют по направлению переднего хода машины.

Решения для уборки урожая подразделения Ag and Turf — товарные знаки

AccuDepth™	Quick Fill™	STS™
AutoTrac™	Refuge Ready™	TouchSet™
BoomTrac™	Row-Trak™	Nothing Runs Like a Deere™
CCS™	RowCommand™	Tru-Depth™
FieldVision™	SeedStar™	TruPosition™
Flex-Fold™	CommandARM™	TwinFluid GreenStar™
CommandCenter™	VacuMeter™	Hi-Cycle™
John Deere™	VRS™ (система VariRow)	HillMaster™
Level-lift™	Funk™	PRO-12™
Load Command™	iTorque™	PRO-16™
MaxEmerge™	Phoenix™	ProDrive™
Maximizer™	PowerTech™	PRO-SERIES™
Service ADVISOR™	TMII™	Pro-Series XP™
SprayMaster™	TMIII™	Pro-Shaft™
StarFire™		

Решения для уборки урожая подразделения Ag and Turf — термины и сокращения

Фраза	Значение	Фраза	Значение
A/C	Система кондиционирования воздуха	NLA	Выпуск прекращен
ALSO ORDER	Также закажите	NSEP	Недоступно по отдельности
APPL	Только для этой машины	OD	Наружный диаметр
AR	По мере необходимости	OPTION	Опция
ASSY	Узел в сборе	OPTIONAL	Дополнительное оборудование
BCU	Основной блок управления	OR	Или
CNLA	Выпуск в сборе прекращен (заказывать отдельные детали)	ORD	Заказ
ECU	Блок управления двигателем	ORD W/	Заказ с
ETC	Электронный регулятор температуры	OS	Увеличенный размер
FI	Комплект для установки в полевых условиях	PKG	Упаковка
FIP	Топливный насос высокого давления	RATIO	Соотношение
FOR	Для	RCU	Блок управления реверсом
FRONT	Передний	REAR	Задний
GSD	Дисплей GreenStar™	REMAN	Восстановленный
HTC	Блок управления нагревателем	RH	Правый
ID	Внутренний диаметр	STD	Стандартный
INCL	Содержит	SUB	Заменен на
INCL KEYS	Включая ключи	SUB FOR	Замена для
JDL	Блок управления JDLink™	TK	Толщина
KIT	Комплект	UIC	Блок управления интерфейсом пользователя
LGTH	Длина	UIM	Блок пользовательского интерфейса
LH	Левый	UP	Верхний
LOW	Нижний	USE WITH	Использовать с
MARKED	Маркированный	W/	С
MF	Сделайте из	W/O	Без
NA	Не применимо	Z	Номер шестерни и зубьев звездочки
L	Количество звеньев цепи		

P
R
O
O
F
P
R
O
O
F

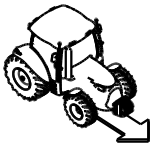

Palonnier fixe 4N-D3 Std
Fixed hitched 4N D3 Std

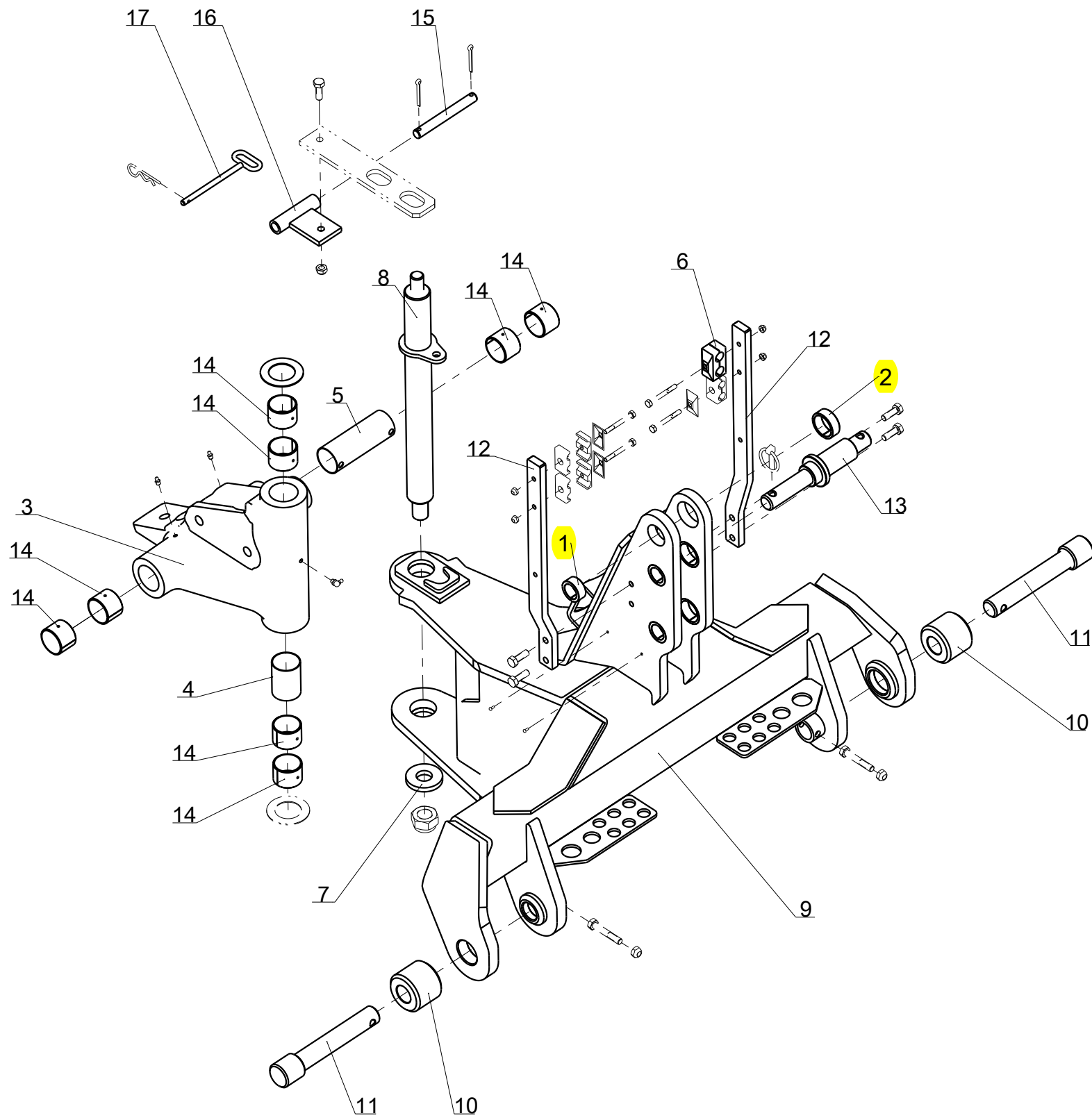

<i>Index</i>	<i>Quantite</i>	<i>Reference</i>	<i>Designation</i>
1	3	5GB122 198	Steel bush 45x32, Lg:20
2	3	5GB122 199	Steel bush 55x45, Lg : 20
3	1	5GB1 223 210 U	Cast iron cardan joint 110°
4	1	5GB1 223 221	Grease casing for cardan joint (front)
5	1	5GB1 223 222	Grease casing for cardan joint (rear)
6	1	5GB1 235 106	Double hose fixation 2x20 cpl.
7	1	5GB122 106	Special washer - 30.5x70x10
8	1	5GB122 128	Vertical pin SP 110°- Dia 50, lg. : 605 mm, thread 2.00
9	1	5GB122 191	Hitch point SP fixed 3N / 4N
10	2	5GB122 193	Coupling
11	2	5GB122 194	Coupling
12	2	5GB122 195	Hose support / Headstock
13	1	5GB122 197	3 point hitch top link pin Cat III / IV
14	8	5GB122 246	Bronze bushing - Dia50x55, lg. : 40 mm
15	1	5GB122 249	Bracket parking latch pin - Dia 18, lu. : 140 mm
16	1	5GB122 273	Rear parking latch bracket
17	1	5GB122 292	Pin parking latch - Dia 10, lg. : 158 mm

Palonnier fixe 4N-D3 Std
Fixed hitched 4N D3 Std

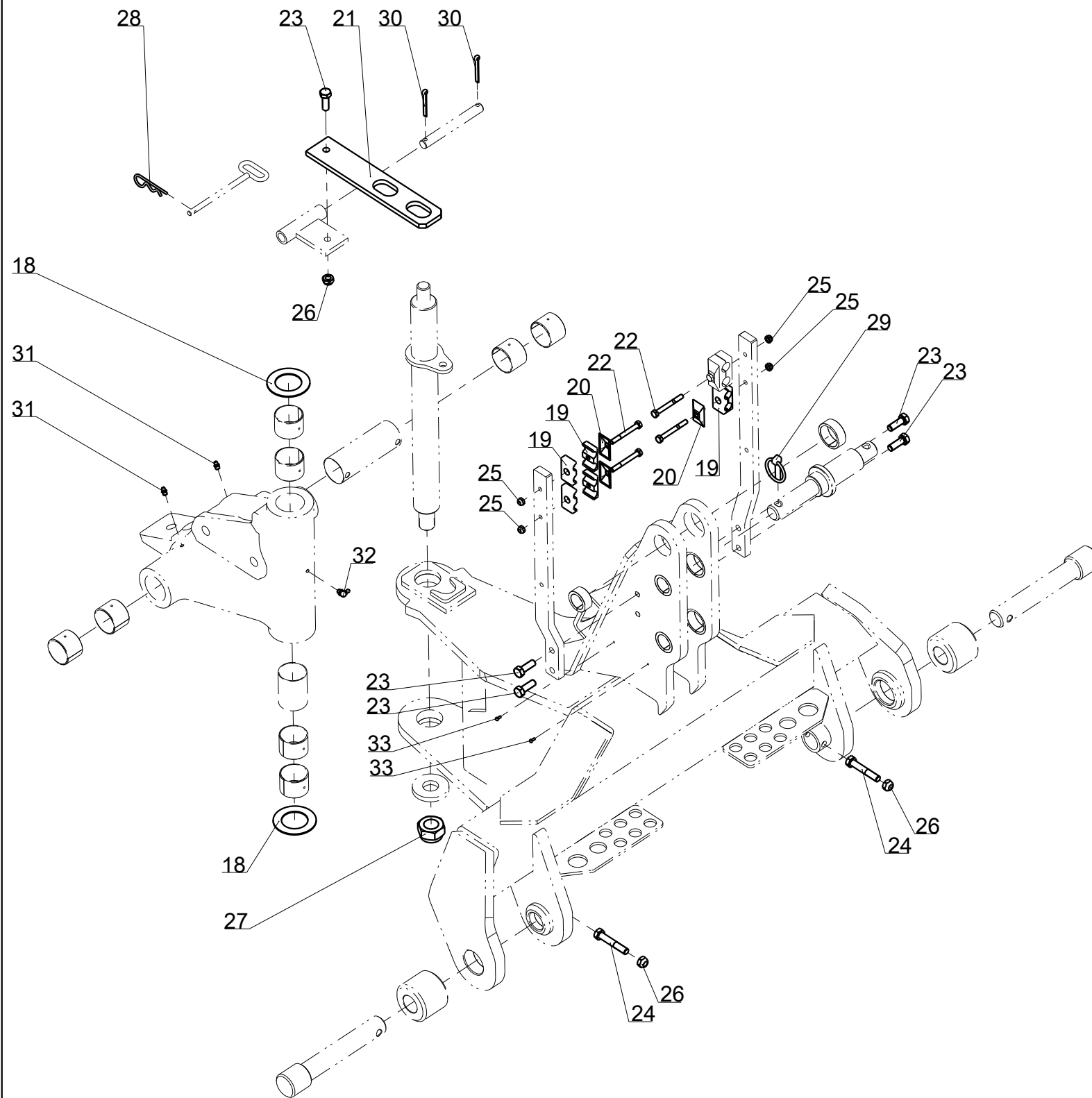
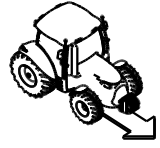

<i>Index</i>	<i>Quantite</i>	<i>Reference</i>	<i>Designation</i>
18	2	5GB122 295	Special washer - 50.5x82x2
19	6	5GB122 360	Double hose fixation 2x16
20	3	5GB122 361	Upper plate convex - hose fixation 2x16 28x49
21	1	5GB122 373	Front parking latch bracket - lg. : 315 mm
22	4	5GBVI 27 12	Screw H M8x 70 - 8.8 ZNBL
23	5	5GBVI 29 05	Screw H M12x 35 - 8.8 ZNBL
24	2	5GBVI 29 16	Screw H M12x 70 - 8.8 ZNBL
25	4	5GBVJ 320	Nyloc nut std H M 8 - 8 ZNBL
26	3	5GBVJ 322	Nyloc nut std H M 12 - 8 ZNBL
27	1	5GBVJ 335	Nyloc nut std H M 30 - 8 ZNBL - thread 200
28	1	5GBVL 002	R Clip - 4, Z
29	1	5GBVL 103	Lynch pin "Clips" Dia10 Z
30	2	5GBVL 414	Split pin V 6.3x50
31	2	5GBVM 201	Grease nipple - M8, thread125
32	1	5GBVM 203	Grease nipple 90° M8x125
33	2	5GBVM 410	Fluted round head nail4x9

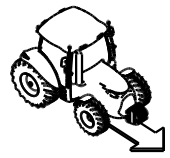

Kit key 36/46

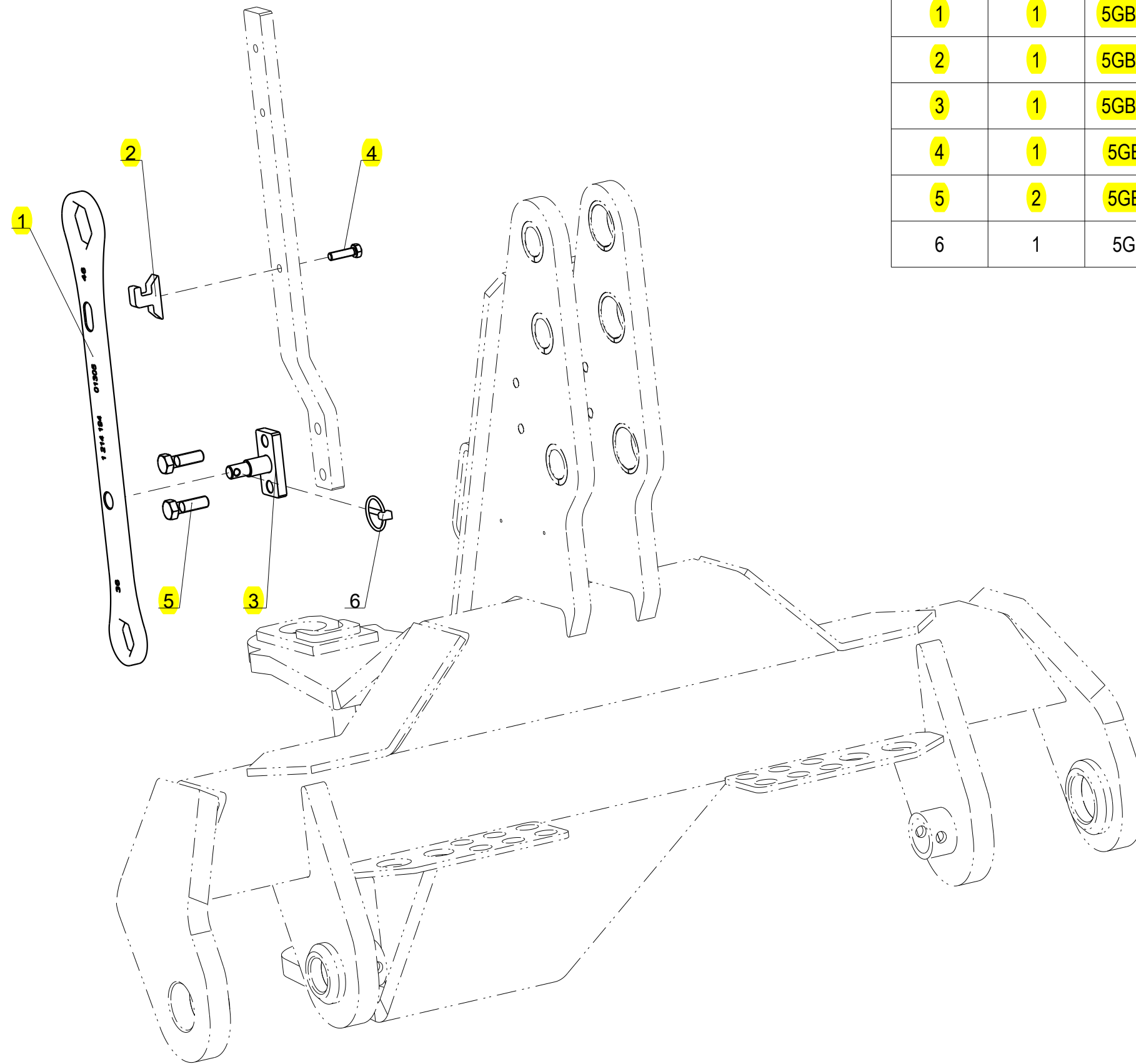

Index	Quantité	Référence	Designation
1	1	5GB1 214 194	Key 36/46
2	1	5GB1 214 195	Axle support key
3	1	5GB1 214 196	Key support
4	1	5GBVI 27 06	Screw H M8x 30 - 8.8 ZNBL
5	2	5GBVI 29 07	Screw H M12x 40 - 10.9 ZNBL
6	1	5GBVL 101	Lynch pin "Clips" Dia6 Z

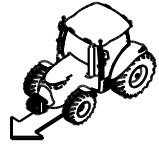

Kit decompression retournement
Decompression hydraulic kit (Turnover)

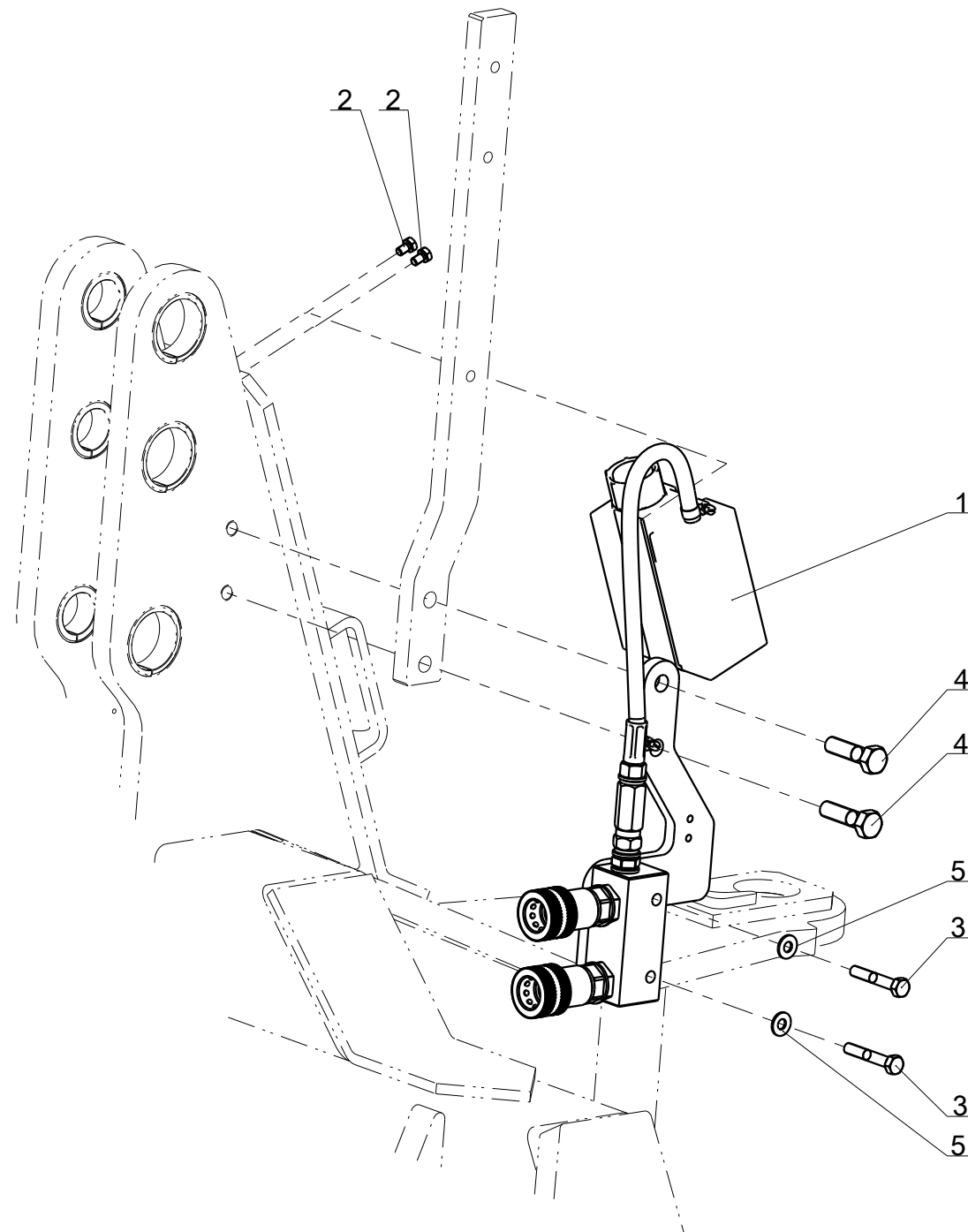

<i>Index</i>	<i>Quantite</i>	<i>Reference</i>	<i>Designation</i>
1	1	5GB1 122 404	Kit decompression retournement Decompression Kit (complet)
2	2	5GBVI 26 01	Vis H M6x 10 - 8.8 ZNBL Screw H M6x 10 - 8.8 ZNBL
3	2	5GBVI 27 10	Vis H M8x 50 - 8.8 ZNBL Screw H M8x 50 - 8.8 ZNBL
4	2	5GBVI 29 08	Vis H M12x 45 - 8.8 ZNBL Screw H M12x 45 - 8.8 ZNBL
5	2	5GBVK 502	Rondelle plate MU8 ZNBL Flat washer MU8 ZNBL

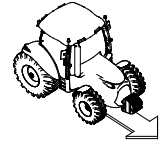

Retournement semi-portée mono-roue
Turnover Semi-Mounted Single wheel

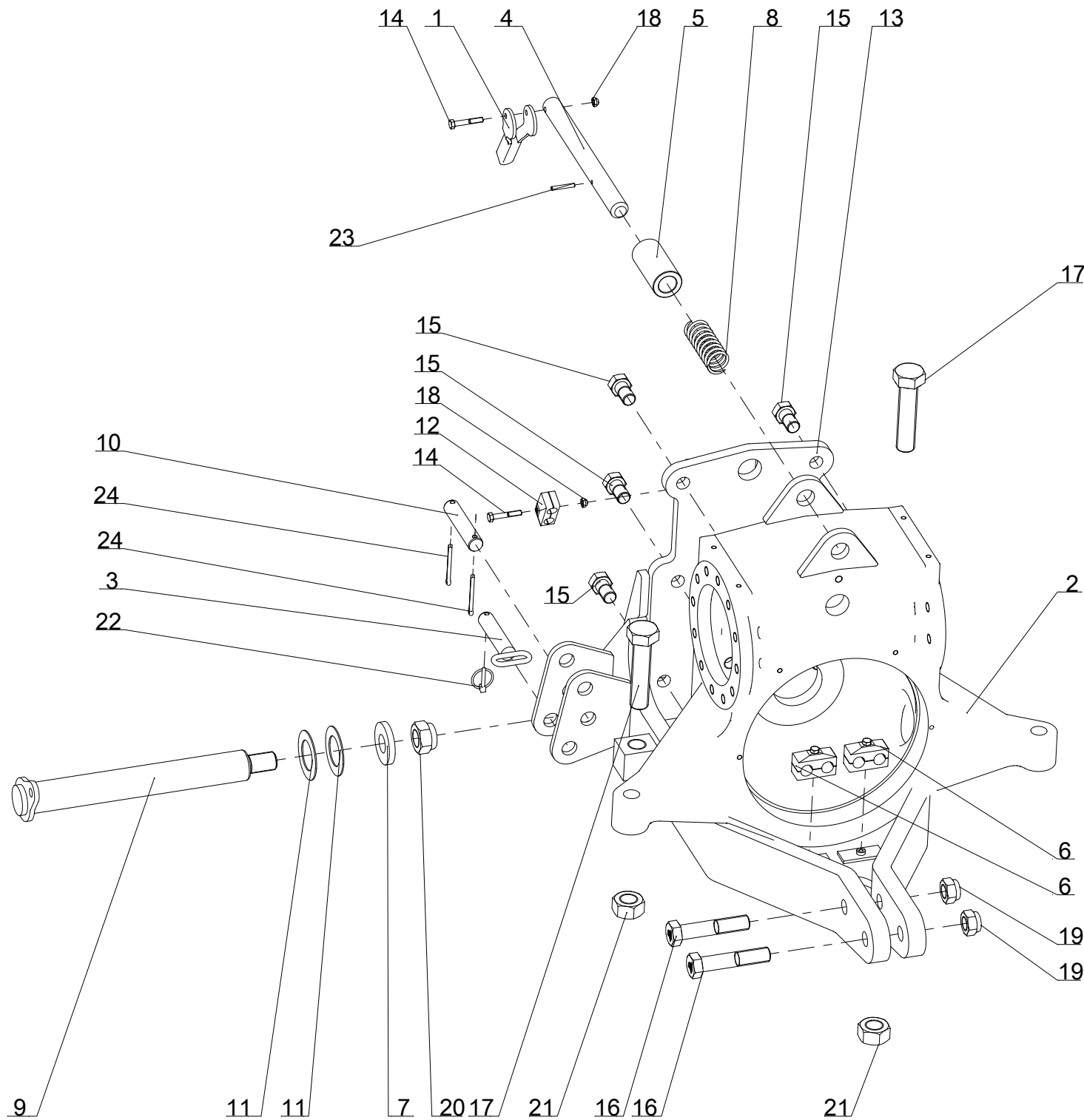

Repere	Quantite	Reference	Designation
1	1	5GB1 123 115	Handle for transport pin
2	1	5GB1 223 152 U	headstock casting
3	2	5GB1 223 164	Parking leg pin
4	1	5GB1 223 173	Transport lock pin
5	1	5GB1 223 211	Socket (transport lock)
6	2	5GB1 235 106	Double hose fixation 2x20 cpl.
7	1	5GB122 106	Special washer - 30.5x70x10
8	1	5GB122 224	Spring N°12 bis for transport lock - Dia 40, lg. : 110 mm
9	1	5GB122 250	Horizontal crucifix pin - Dia 50, Lu:378mm,M30
10	2	5GB122 253	Parking leg pin - Dia 25, Lu:100 mm
11	2	5GB122 295	Special washer - 50.5x82x2
12	1	5GB122 358	Double hose fixation 2x16 cpl.
13	1	5GB122 375	Headstock frame
14	2	5GBVI 27 10	Screw H M8x 50 - 8.8 ZNBL
15	6	5GBVI 34 01	Screw H M22x 40 - 8.8 ZNBL , thread /25 mm
16	2	5GBVI 35 06	Screw H M24x120 - 8.8 ZNBL
17	2	5GBVI 47 03	Screw H M30x130 - 10.9 ZNBL
18	2	5GBVJ 320	Nyloc nut std H M 8 - 8 ZNBL
19	2	5GBVJ 331	Nyloc nut std H M 24 - 8 ZNBL
20	1	5GBVJ 335	Nyloc nut std H M 30 - 8 ZNBL - thread 200
21	2	5GBVJ 626	Nut HU M30 - 8 ZNBL
22	2	5GBVL 101	Lynch pin "Clips" Dia6 Z
23	1	5GBVL 214	Thick roll pin - 6x40 mm, Zyntek
24	4	5GBVL 415	Split pin V 6.3x60



Retournement semi-portée mono-roue
Turnover Semi-Mounted Single wheel

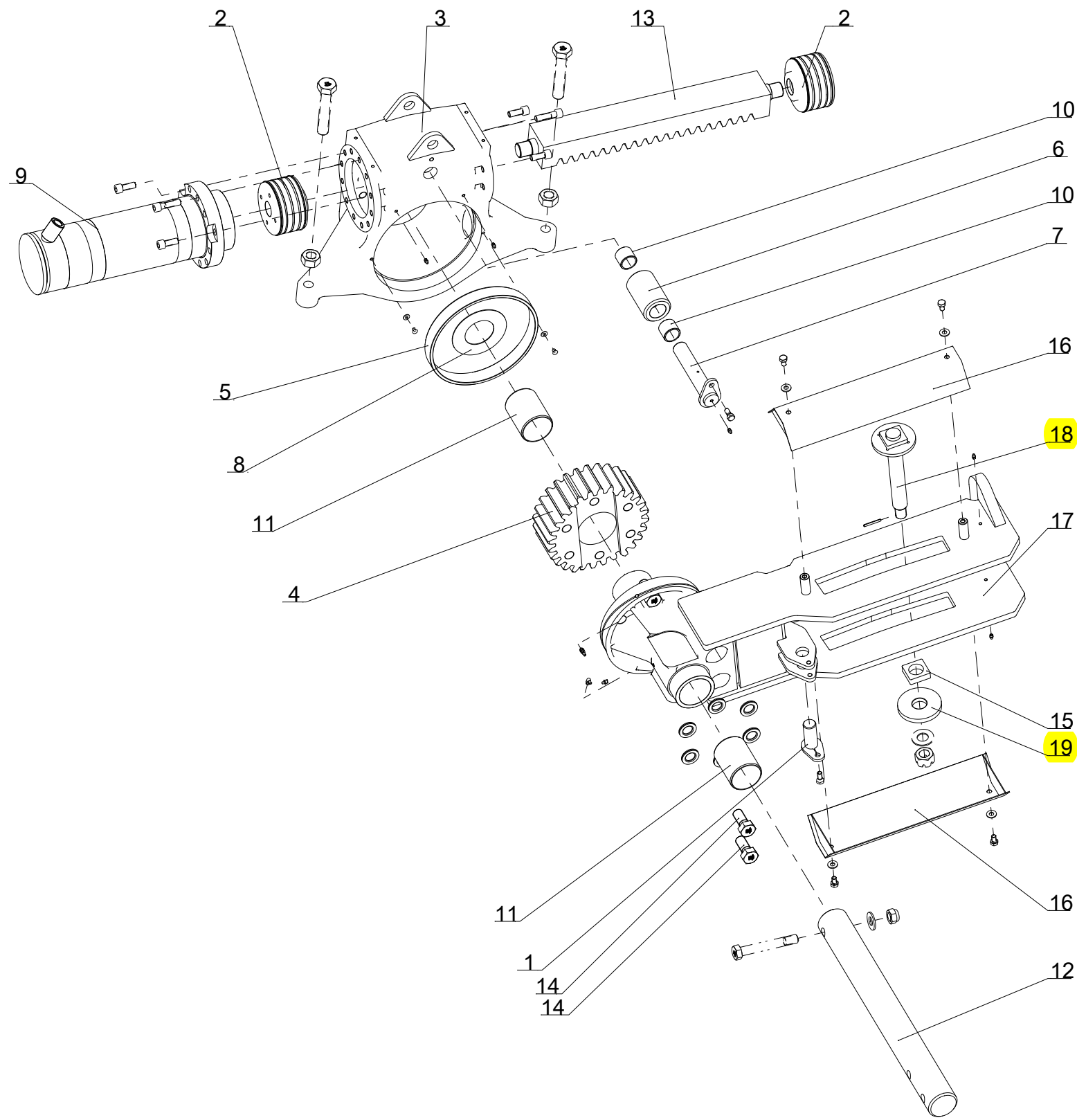

Repere	Quantite	Reference	Designation
1	1	5GB1 116 314	Pin (variwidth ram)
2	2	5GB1 223 117	Piston for cylinder - Dia 150, width : 107 mm
3	1	5GB1 223 152 U	headstock casting
4	1	5GB1 223 155	pinion - width : 133 mm
5	1	5GB1 223 156	Plastic bushing for pinion
6	1	5GB1 223 157	Rack guide bearing
7	1	5GB1 223 158	headstock rollers pin
8	1	5GB1 223 194	Special washer - Dia 85.5x160x2
9	2	5GB1 223 236	Ram semi-mounted Dia150
10	2	5GB1 291 306	Bush composite Dia40x48 Lg=40
11	2	5GB122 231	Plastic bush - Dia 93 x 86
12	1	5GB122 251	Front shaft - Dia 85, lg. : 790 mm
13	1	5GB122 256	rack - width : 100 mm
14	6	5GB122 265	Screw H M27x 60 - 10.9 Znbl, thread /45mm, thread200
15	1	5GB122 284	Adjuster guide block
16	2	5GB122 325	Protection for support pinion
17	1	5GB122 374	Pinion support
18	1	5GB122 385	Front adjuster guide pin
19	1	5GB122 387	Adjuster guide washer



Retournement semi-portée mono-roue
Turnover Semi-Mounted Single wheel

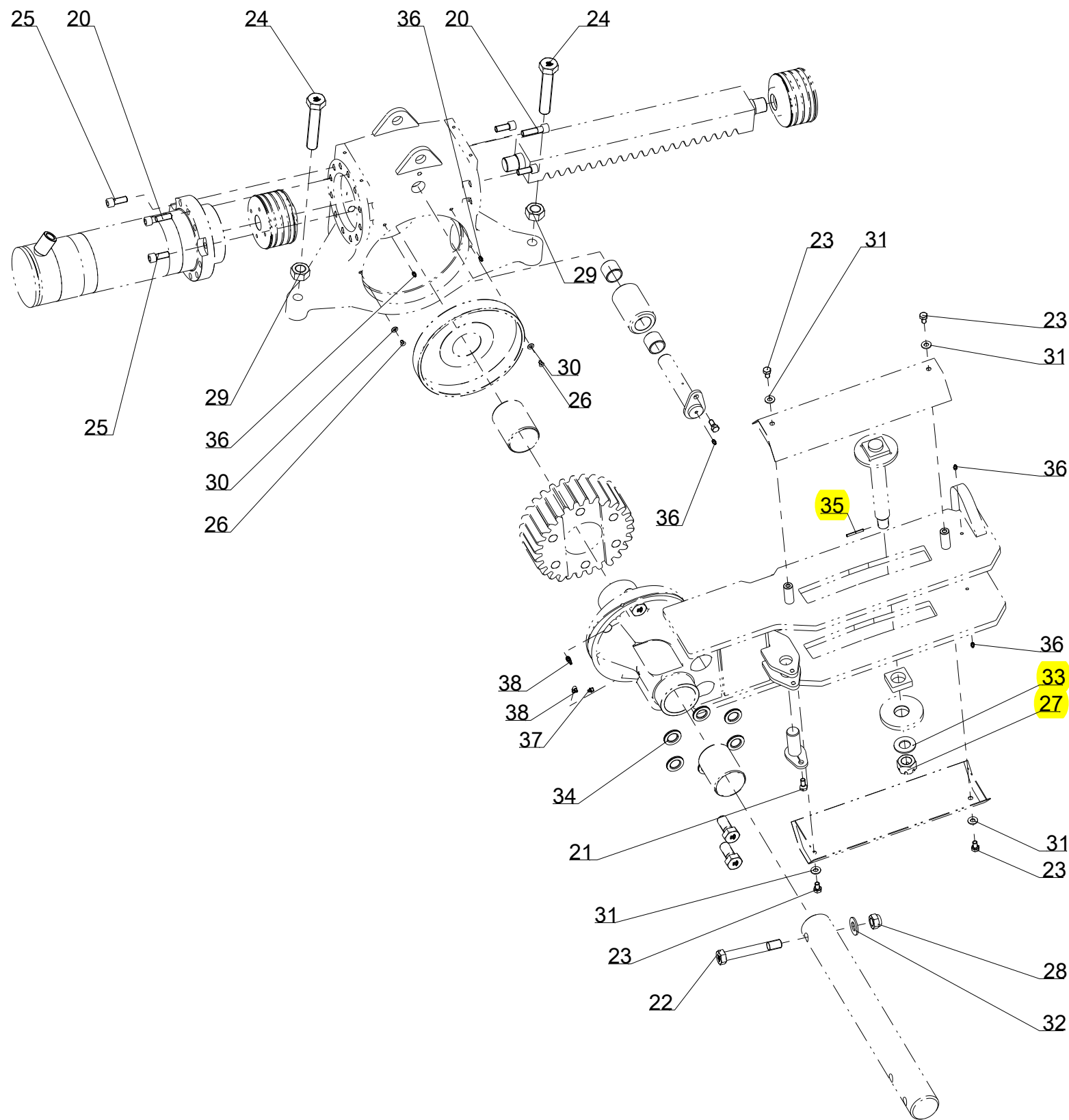

Repere	Quantite	Reference	Designation
20	20	5GB802 503 000	Screw CHc M16x 60 - 8.8 Black
21	2	5GBVI 24 33	Screw H conical M12x22 lg. : 36
22	1	5GBVI 35 15	Screw H M24x170 - 10.9 ZNBL, thread /36 mm
23	4	5GBVI 41 02	Screw H M12x 20 - 8.8 ZNBL
24	2	5GBVI 47 01	Screw H M30x160 - 10.9 ZNBL
25	4	5GBVI 48 24	Screw CHc M16x 40 - 8.8 Black
26	2	5GBVI 49 02	Screw FHC M8x 12 - 10.9 Black
27	1	5GBVJ 208	Nut HK M 30x 200 - 8 - ZNBL , Ht:29
28	1	5GBVJ 331	Nyloc nut std H M 24 - 8 ZNBL
29	2	5GBVJ 626	Nut HU M30 - 8 ZNBL
30	2	5GBVK 502	Flat washer MU8 ZNBL
31	4	5GBVK 504	Flat washer MU12 ZNBL
32	1	5GBVK 510	Flat washer MU24 ZNBL
33	1	5GBVK 513	Flat washer MU30 ZNBL
34	6	5GBVK 522	Washer ZNBL NL27
35	1	5GBVL 215	Thick roll pin - 6x50 mm
36	5	5GBVM 201	Grease nipple - M8, thread125
37	1	5GBVM 205	Grease nipple - M10, thread150
38	2	5GBVM 207	Grease nipple 90° M10x150

Direct turnover, semi-mounted plow

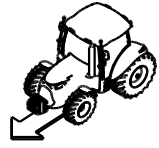

Index	Quantite	Reference	Designation
1	1	5GB1 214 230	Kit pressure limiter
2	1	5GB1 223 112	Support (hydraulic block)
3	4	5GBVI 27 03	Screw H M8x 16 - 8.8 ZNBL

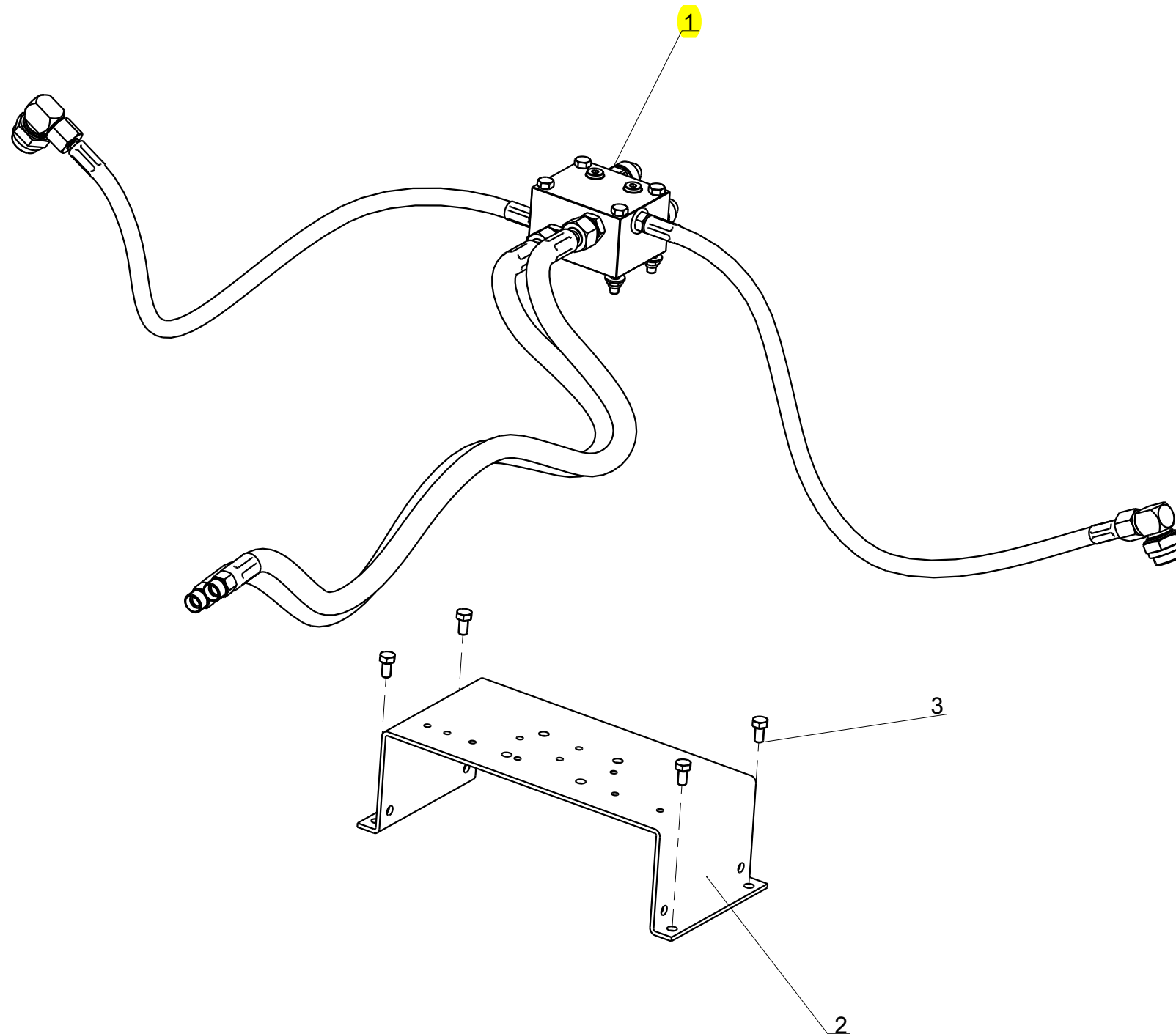



Kit pressure limiter

Index	Quantité	Référence	Designation
1	1	5GB1 214 231	Pressure limiter 18OB
2	2	5GB1 214 233	Hydraulic hose 5/16 Lg:800, F12-M3/8
3	2	5GB1 223 131	Hydraulic hose - Dia 1/2", lg. :3000mm, F15-MVA18
4	2	5GB1 231 523	Union M15 + M3/8 Cyl
5	2	5GB1 231 554	Swivel elbow M12 - 3 / 4G
6	2	5GB10 248	Ring BS 17
7	4	5GBVI 27 13	Screw H M8x 80 - 8.8 ZNBL
8	4	5GBVJ 320	Nyloc nut std H M 8 - 8 ZNBL
9	4	5GBVK 502	Flat washer MU8 ZNBL

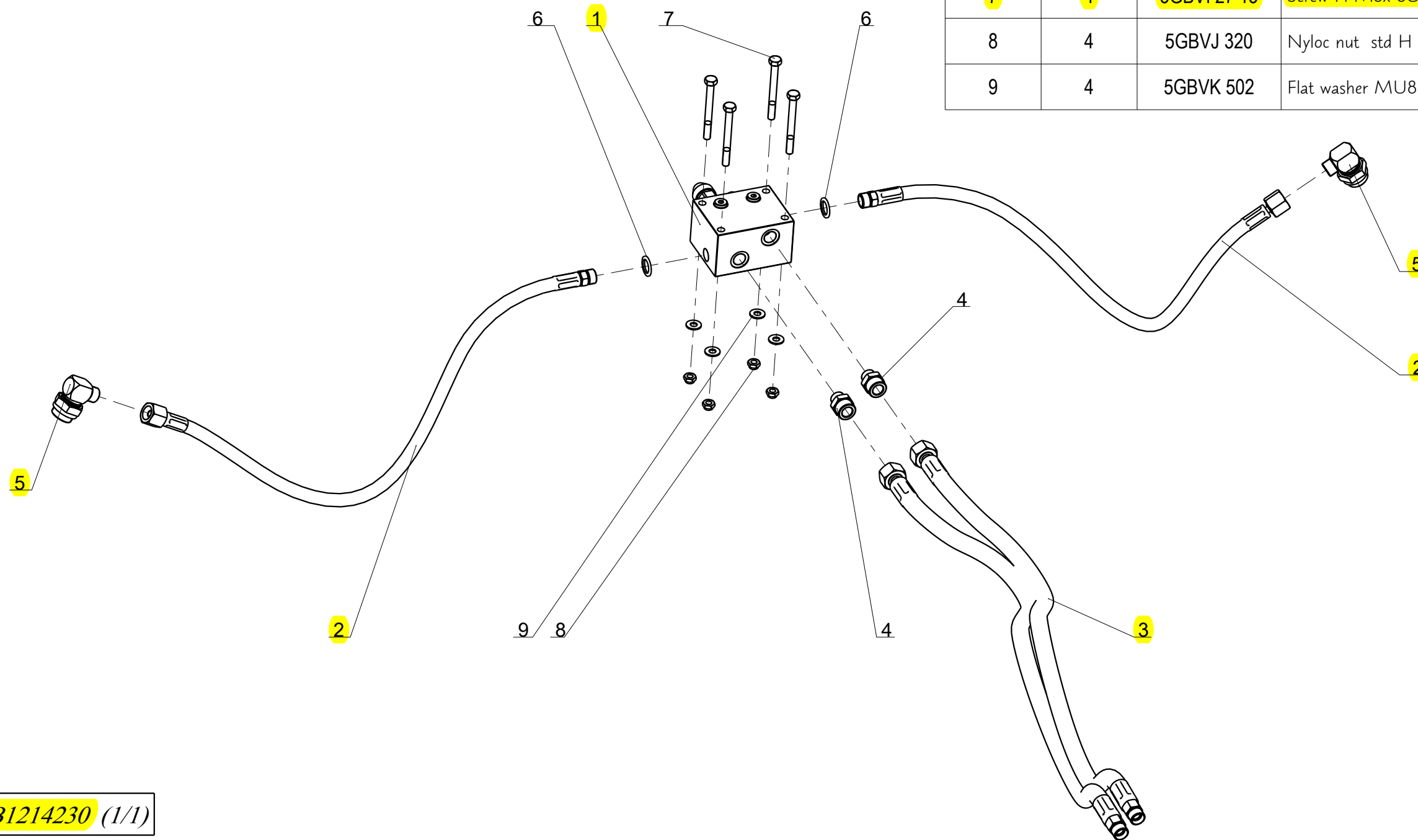

Deport Mecanique / Monoroue

Mechanical front furrow

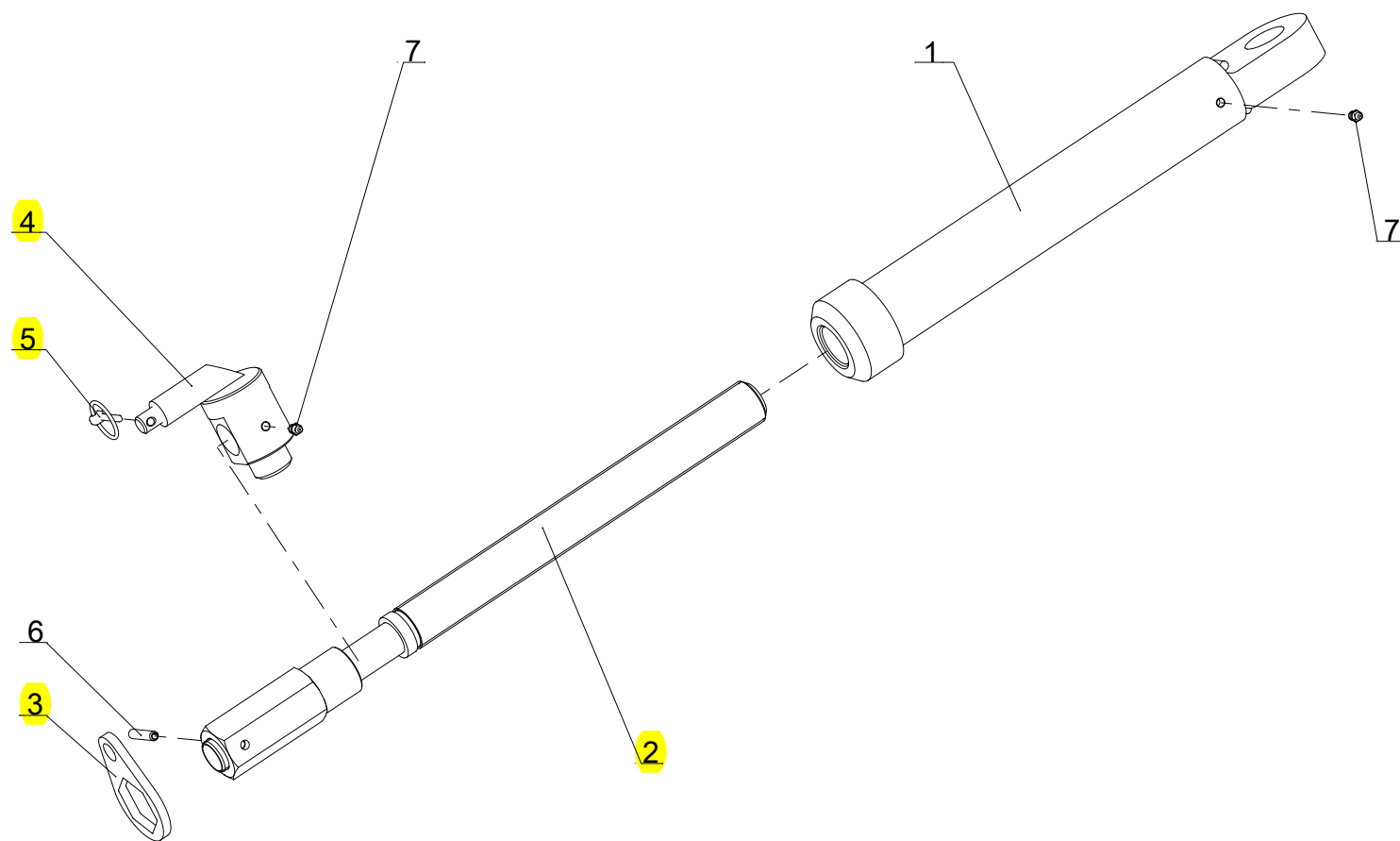

Index	Quantité	Reference	Designation
1	1	5GB122 327	Mechanical Front adjuster nut
2	1	5GB122 328	Mechanical Front adjuster eye end
3	1	5GB122 386	Retainer / Mechanical front adjuster
4	1	5GB122 389	Mechanical Front adjuster outer pin
5	1	5GBVL 101	Lynch pin "Clips" Dia6 Z
6	1	5GBVL 222	Thick roll pin - 8x45 mm, ZNBL
7	2	5GBVM 201	Grease nipple - M8, thread125

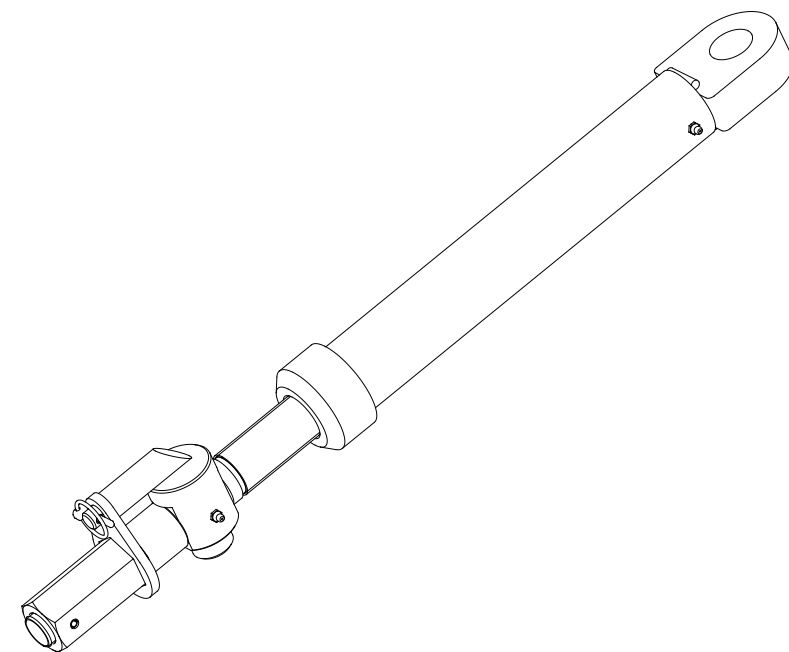



Ram + piston turnover

Repere	Quantité	Reference	Designation
1	1	5GB1 223 117	Piston for cylinder
2	1	5GB1 223 118	Seal kit for Piston for cylinder - Dia 150, width : 107 mm
3	1	5GB1 223 236	Ram semi-mounted Dia150
4	1	5GB122 364	Parachute valve Hawe 3/4"

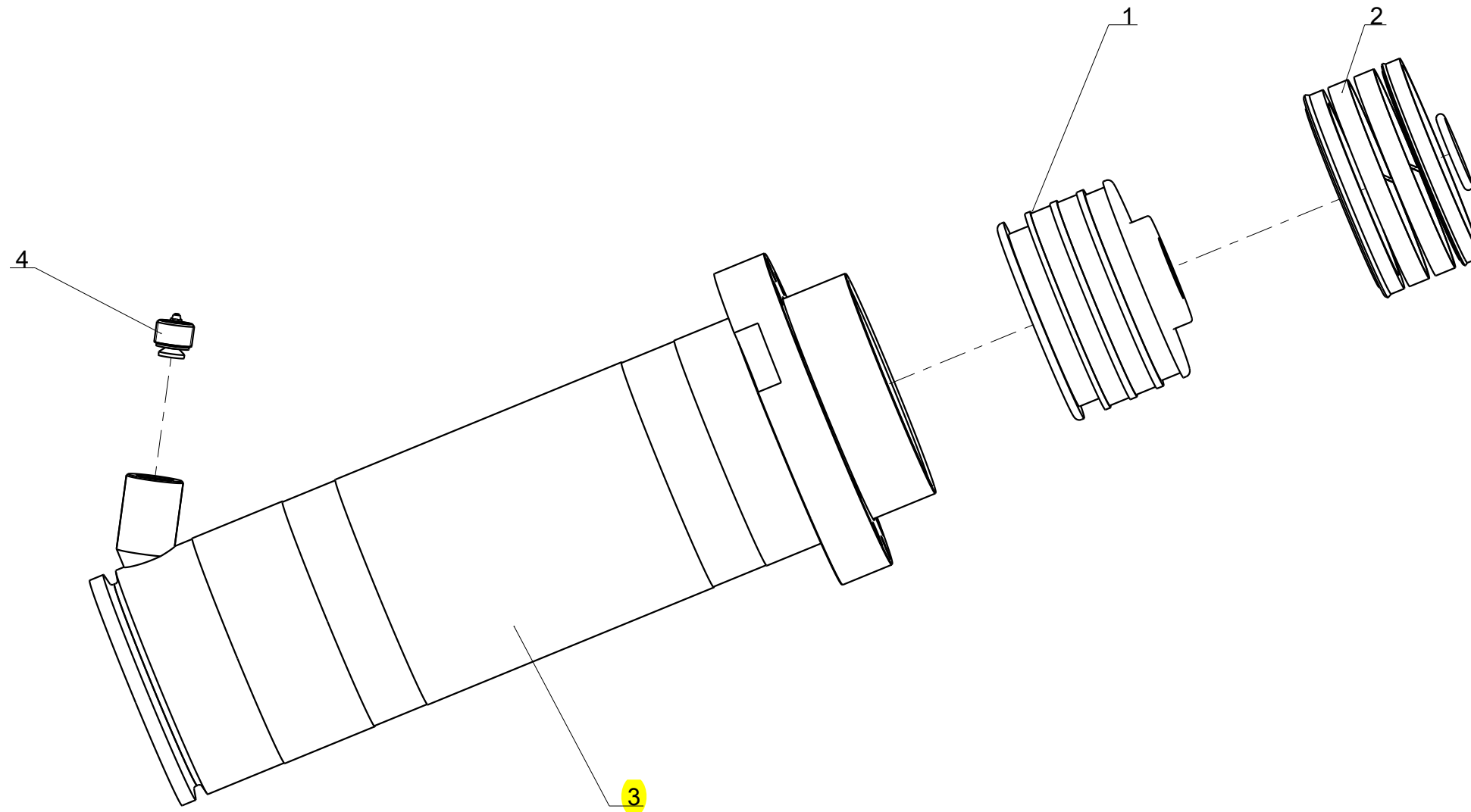

Stabilizer bar 2446mm (2), Beam 5-furrow (1000)

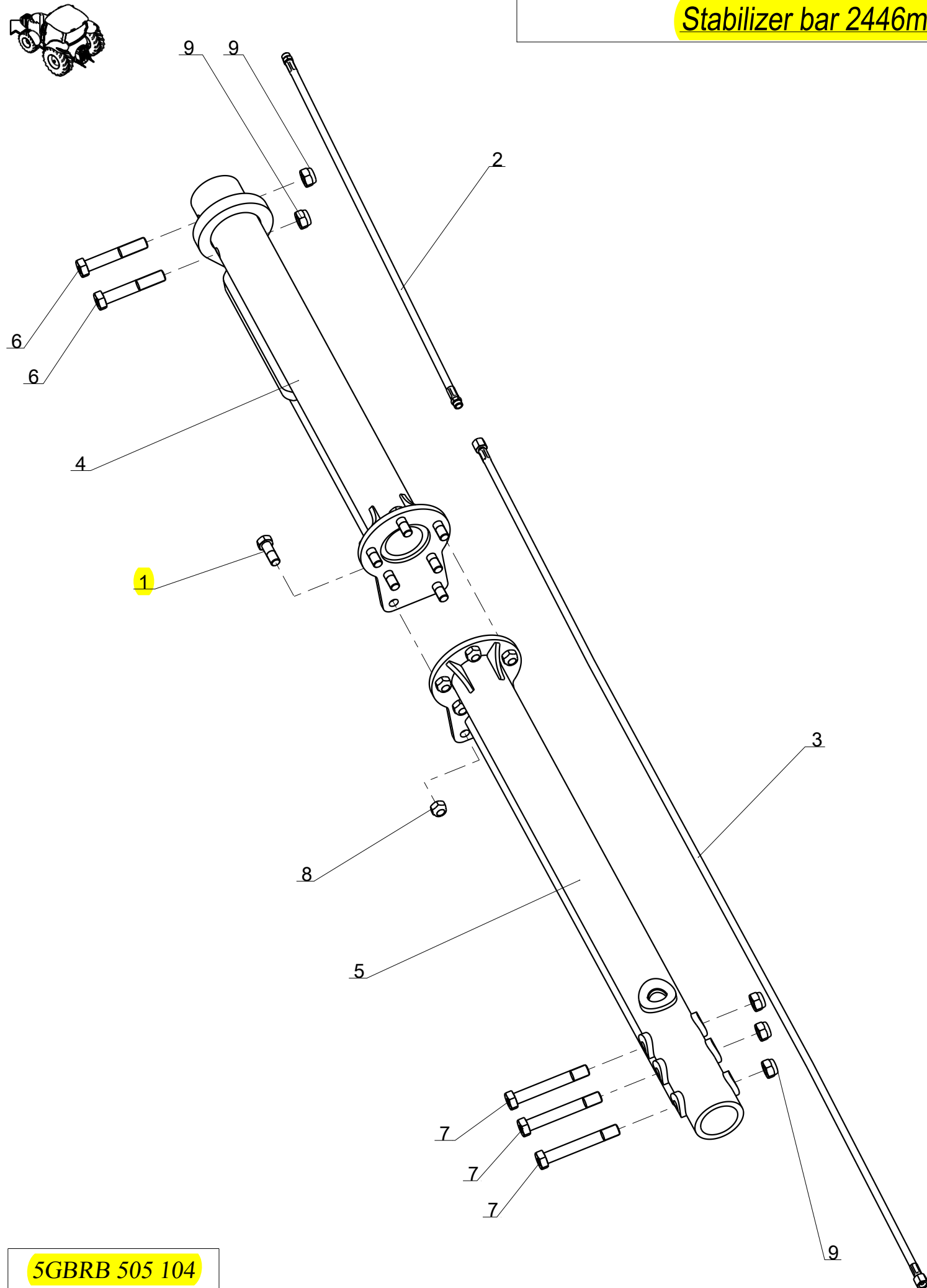

Repere	Quantité	Reference	Designation
1	7	5GB1 116 169	Screw H M20x55 - 10.9 ZNBL, thread /27 mm
2	1	5GB1 212 126	Hydraulic hose - 5/16", Lg. : 1040 mm, M12-M12
3	1	5GB1 212 134	Hydraulic hose - 5/16", Lg. : 2840 mm, F12-F12
4	1	5GB1 212 168	Stabilizer bar (front) Lg:1068mm
5	1	5GB1 212 171	Stabilizer bar (rear) Compact Lg:1378mm
6	2	5GBVI 35 08	Screw H M24x140 - 8.8 ZNBL
7	3	5GBVI 35 15	Screw H M24x170 - 10.9 ZNBL, thread /36 mm
8	7	5GBVJ 327	Nyloc nut std H M 20 - 8 ZNBL
9	5	5GBVJ 331	Nyloc nut std H M 24 - 8 ZNBL

if need for hydraulic hose protection, order the desired length

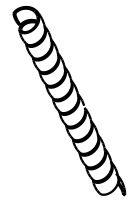
Picture	Qty / Количество	Reference / N° по каталогу	Designation / Наименование
	meter	5GB1116581	Plastic flat spring Dia 15mm Рессора плоская пластмассовая Dia15mm
	meter	5GB1116582	Plastic flat spring Dia 20mm Рессора плоская пластмассовая Dia20mm
	meter	5GB1116580	Plastic flat spring Dia 13mm Рессора плоская пластмассовая Dia13mm
	meter	5GB1116546	Plastic flat spring Dia25-40mm Рессора плоская пластмассовая Dia25-40mm

5GBRB 505 104

30-Apr-13

Revision : B
M a J : 18-Mar-15

Caisson 5 corps (1000) Monoroue (Av+4)

Beam 5-furrow (1000) (Front+4)

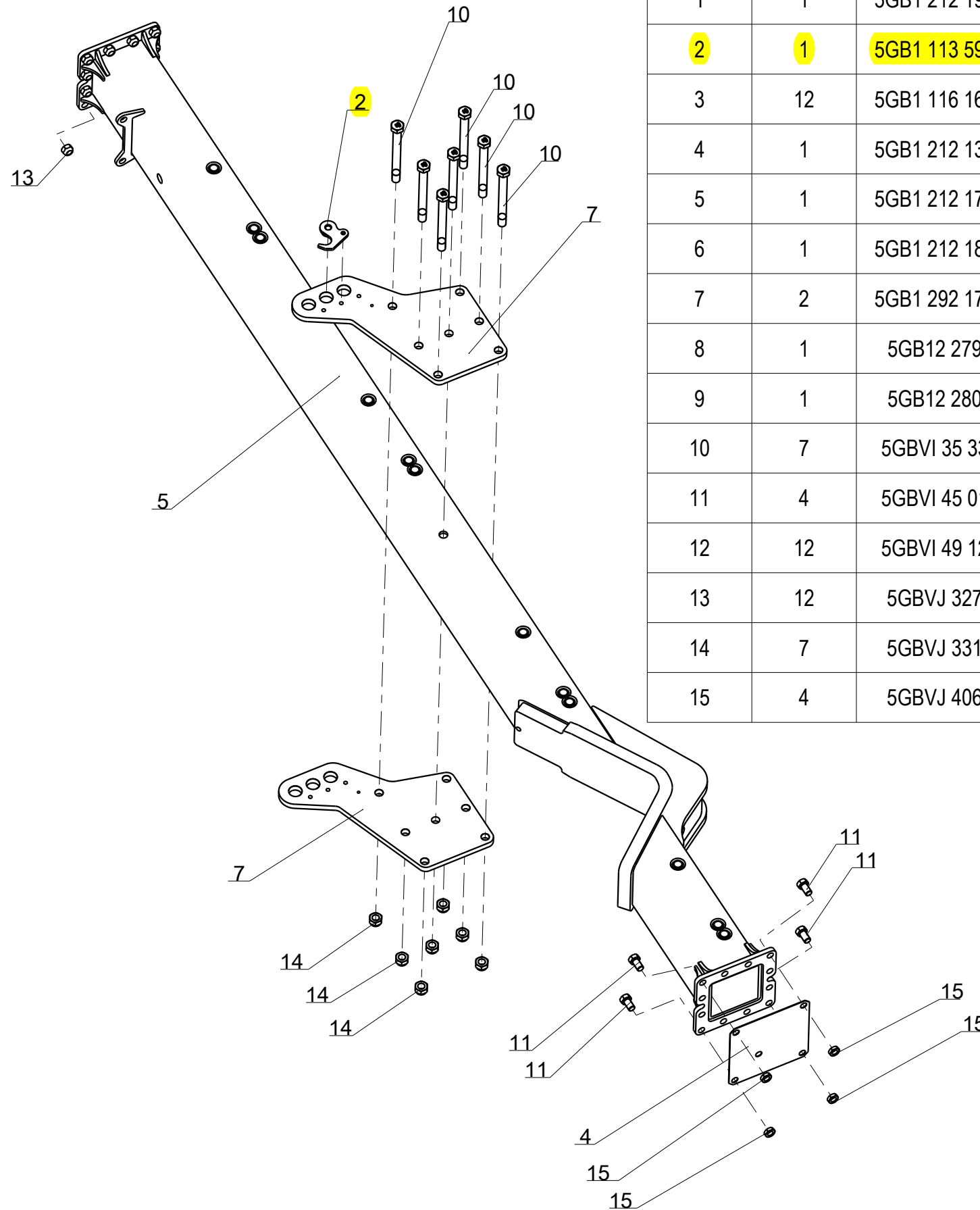
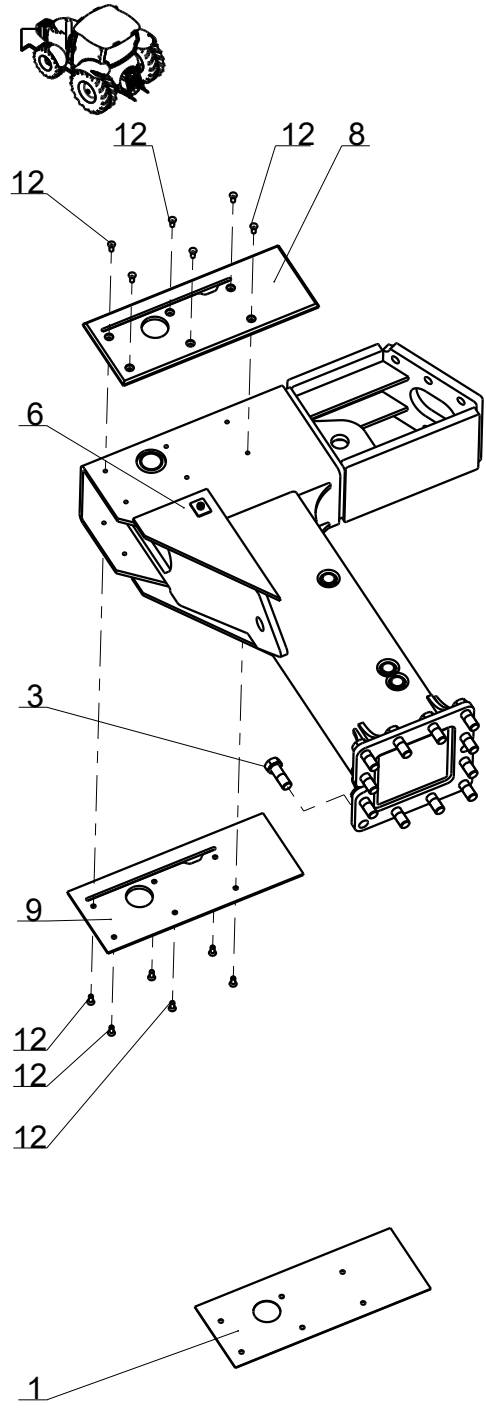

Repere	Quantité	Reference	Designation
1	1	5GB1 212 191	Spacer of wedging (option)
2	1	5GB1 113 599	Shaft stop
3	12	5GB1 116 169	Screw H M20x55 - 10.9 ZNBL, thread /27 mm
4	1	5GB1 212 138	Main beam closing plate
5	1	5GB1 212 176	Rear beam 4-furrow (1000)
6	1	5GB1 212 188	Front element / Beam
7	2	5GB1 292 178	Beam plate
8	1	5GB12 279	Slide protection plate L.H.
9	1	5GB12 280	Slide protection plate R.H.
10	7	5GBVI 35 33	Screw H M24x250 - 10.9 ZNBL, thread /36 mm
11	4	5GBVI 45 01	Screw H M20x 35 - 8.8 ZNBL
12	12	5GBVI 49 12	Screw FHC M8x 20 - 10.9 ZNBL
13	12	5GBVJ 327	Nyloc nut std H M 20 - 8 ZNBL
14	7	5GBVJ 331	Nyloc nut std H M 24 - 8 ZNBL
15	4	5GBVJ 406	Nut Hm M20 - 8 ZNBL

Mechanical Wheel Alignment
Механическая регулировка схождения колес

PY57568 A.1

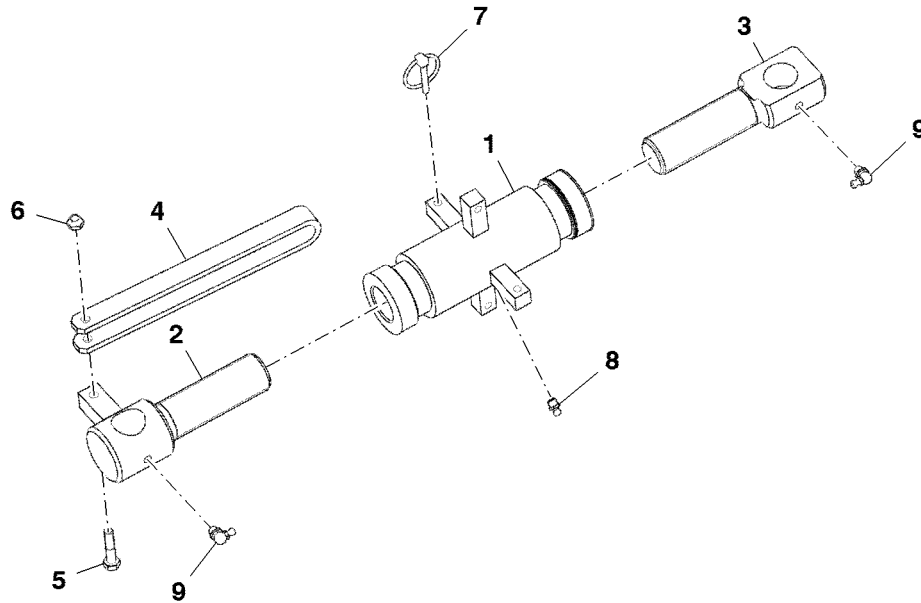

PY57568

Key	Part No.	Part Name	Qty.	Serial No.	Remarks
1	5GB1292105	Barrel	1		
2	5GB1292106	End	1		RH, M36
3	5GB1292107	End	1		LH, M36
4	5GB1292108	Handle	1		
5	5GBVI2708	Screw	1		M8 X 40
6	5GBVJ320	Nut	1		M8
7	5GBVL101	Pin	1		
8	5GBVM201	Grease	1		M8
9	5GBVM203	Grease	2		M8 X 125

P
R
O
O
F

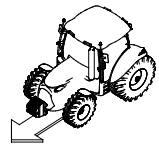

Rear bearing, mounted

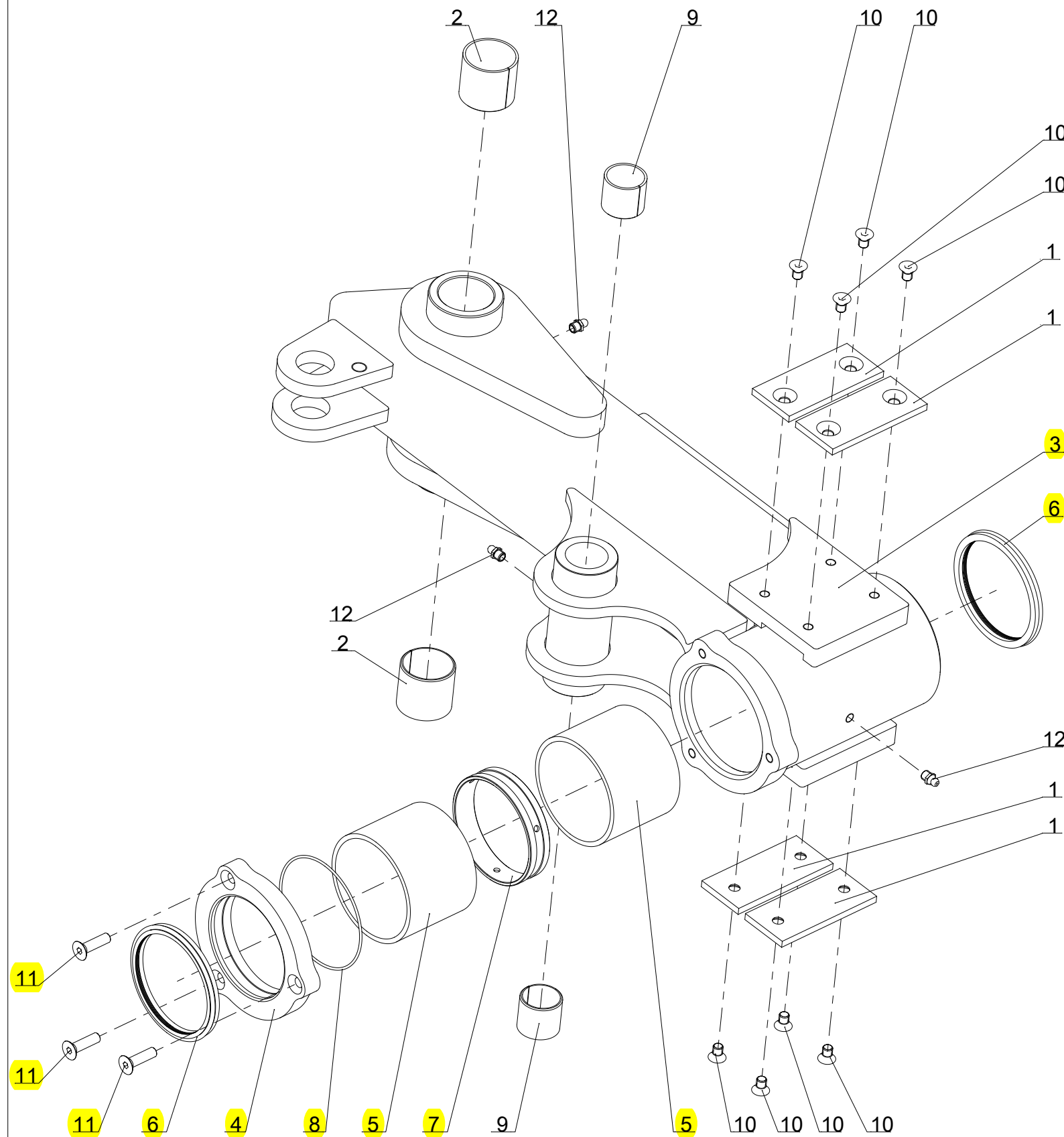

Index	Quantite	Reference	Designation
1	4	5GB 1 118 977 U	Plastic plate - 6x44x100
2	2	5GB 1 231 103	Bush steel Dia 40x44 Lg=40
3	1	5GB 1 292 232	Rear bearing
4	1	5GB 1 292 233	Cover / bearing
5	2	5GB 1 292 234	Composite bush Dia85x93 Lg:70
6	2	5GB 1 292 235	Scraper 85x97.2x8.1
7	1	5GB 1 292 236	Spacer
8	1	5GB 1 292 237	O-Ring 92x2
9	2	5GB 198 231	Bush steel Dia 30x34 Lg=30
10	8	5GB VI 49 02	Screw FHC M8x 12 - 10.9 Black
11	3	5GB VI 49 28	Screw FHC M 8x 30 - 10.9 ZNBL
12	3	5GB VM 201	Grease nipple - M8, thread125



Wheel 1115 16.0/70-20, Single wheel, 8 hole

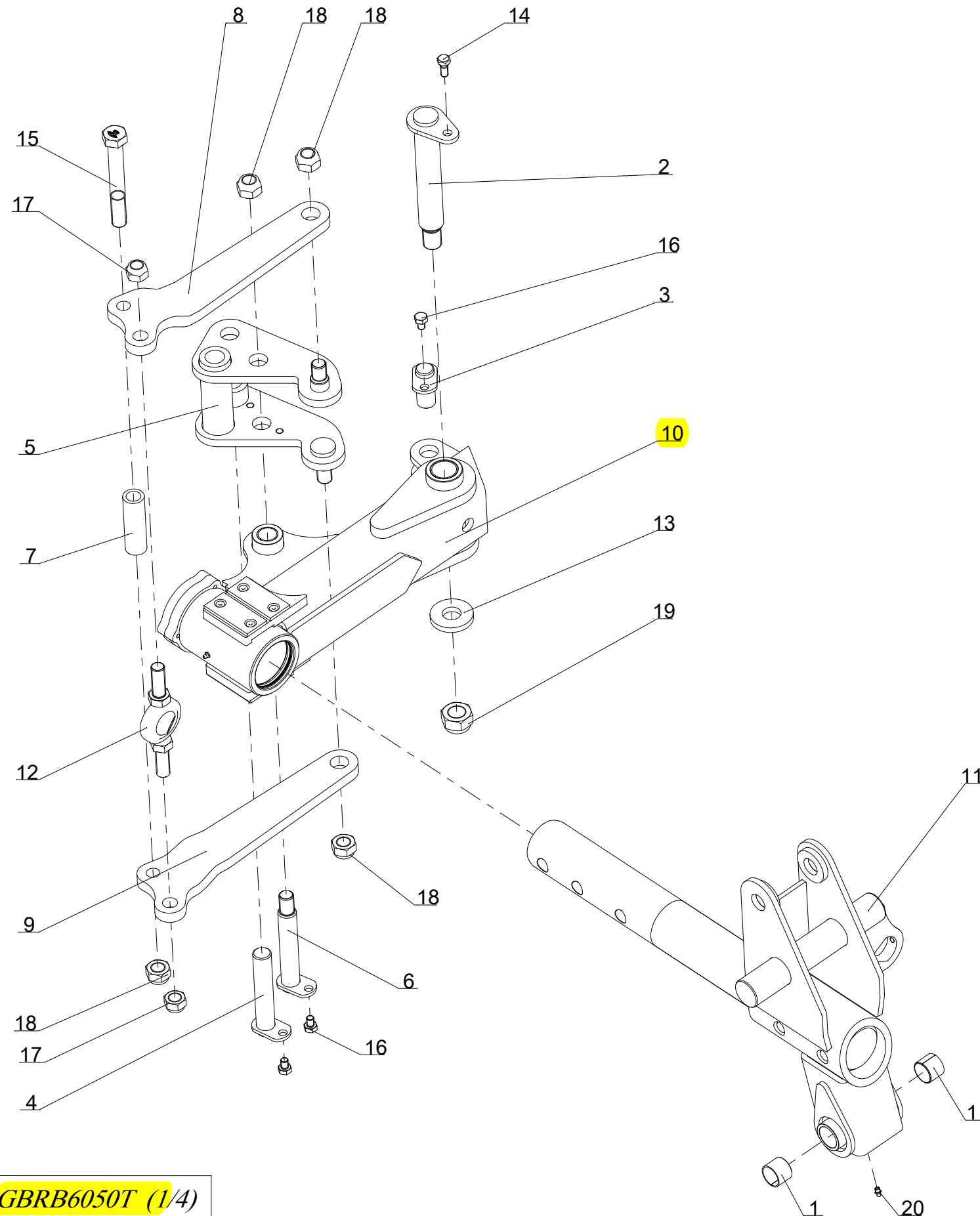

Index	Quantite	Reference	Designation
1	2	5GB1 118 817	Bush steel Dia 35x39 Lg=30
2	1	5GB1 292 103	Rear bearing articulation pin - Dia 40, lg. : 280 mm
3	1	5GB1 292 109	Outer pin for wheel angle adjuster - Dia 30, lg. :75 mm
4	1	5GB1 292 110	Inner pin for wheel angle adjuster - Dia 30, lg. : 170 mm
5	1	5GB1 292 111	Direction pivot link
6	1	5GB1 292 112	Direction pivot link pin - Dia 30, lg. : 200 mm, thread 3.00
7	1	5GB1 292 114	Spacer for steering connecting rod
8	1	5GB1 292 225	Steering rod / wheel L.H.
9	1	5GB1 292 226	Steering rod / wheel R.H.
10	1	5GB1 292 238	Rear bearing, mounted
11	1	5GB12 362	Fixed wheel bracket
12	1	5GB12 705	Axle swivel
13	1	5GB122 106	Special washer - 30.5x70x10
14	1	5GBVI 24 33	Screw H conical M12x22 lg. : 36
15	1	5GBVI 35 16	Screw H M24x180 - 8.8 ZNBL
16	3	5GBVI 41 01	Screw H M12x 16 - 8.8 ZNBL
17	2	5GBVJ 329	Nyloc nut std H M 22- 8 ZNBL
18	4	5GBVJ 331	Nyloc nut std H M 24 - 8 ZNBL
19	1	5GBVJ 335	Nyloc nut std H M 30 - 8 ZNBL - thread 200
20	1	5GBVM 201	Grease nipple - M8, thread125

5GBRB6050T (1/4)

08-Mar-17
Revision : A
MaJ : 09-Mar-17



Wheel 1115 16.0/70-20, Single wheel, 8 hole

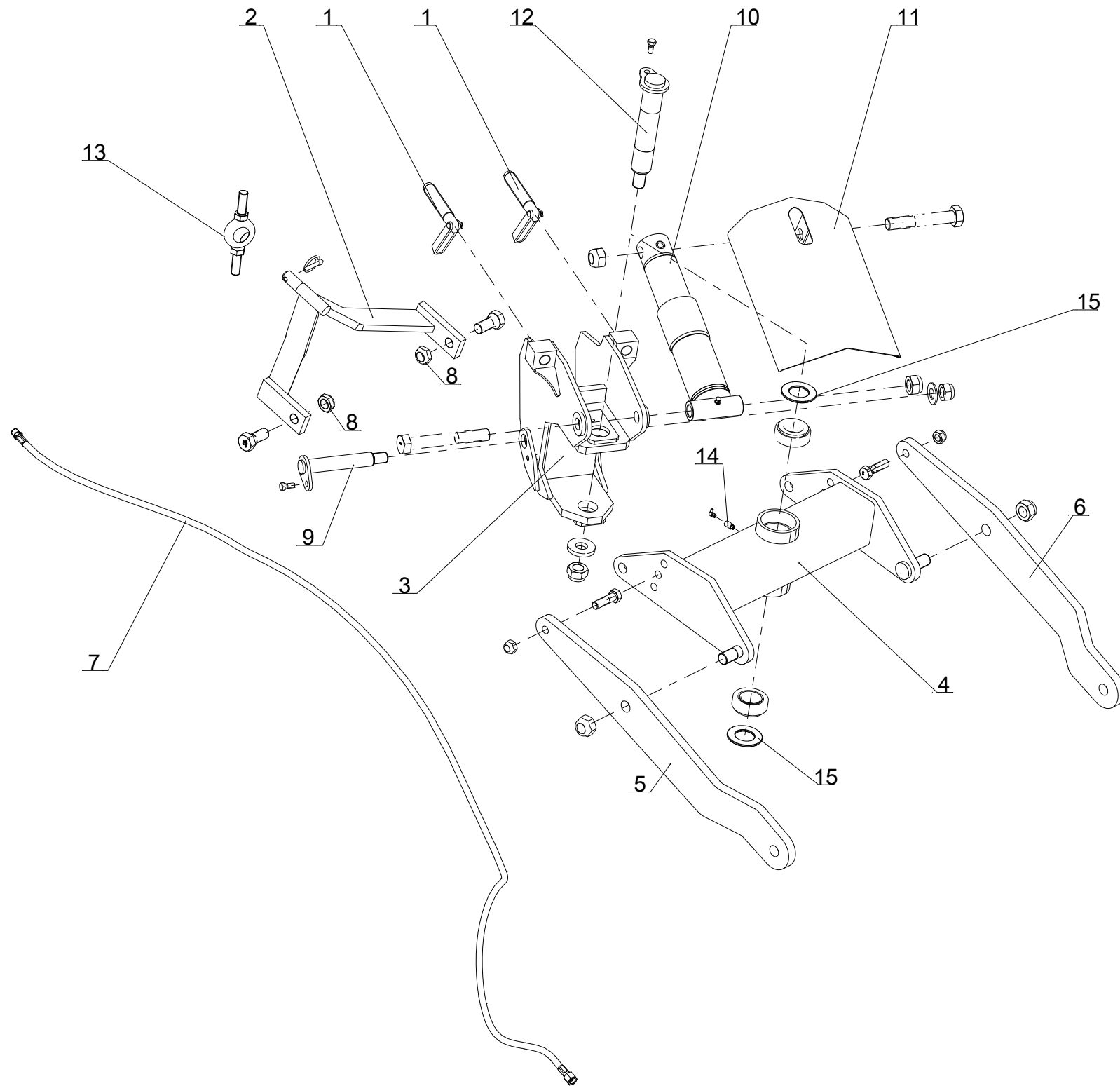

<i>Index</i>	<i>Quantite</i>	<i>Reference</i>	<i>Designation</i>
1	2	5GB1 122 376	Inclination adjustment screw (new) M30, Lg. = 190mm Z
2	1	5GB1 292 115	Steering yoke
3	1	5GB1 292 116	Wheel bracket articulation
4	1	5GB1 292 117	Wheel housing
5	1	5GB1 292 147	Housing support large wheel L.H.
6	1	5GB1 292 148	Housing support large wheel R.H.
7	1	5GB1 292 169	Hydraulic hose - Dia 5/16", lg. : 3830 mm, F12-MVA18
8	2	5GB1 292 182	Nyloc nut special MHB M 27 - thread 200
9	1	5GB12 355	Pin for wheel bracket articulation - Dia 35,lg. : 235 mm, thread 2.00
10	1	5GB12 359	Ram SA 85 Str180
11	1	5GB12 361	Cover protection for wheel cylinder
12	1	5GB12 701	Axle pin D:52 Lg:325 M30x2
13	1	5GB12 705	Axle swivel
14	1	5GB12 738	Greaser extension M10 / M8
15	2	5GB122 104	Special washer for hub or wheel pivot - Dia 89.5 x 50, thick. : 5 mm



Wheel 1115 16.0/70-20, Single wheel, 8 hole

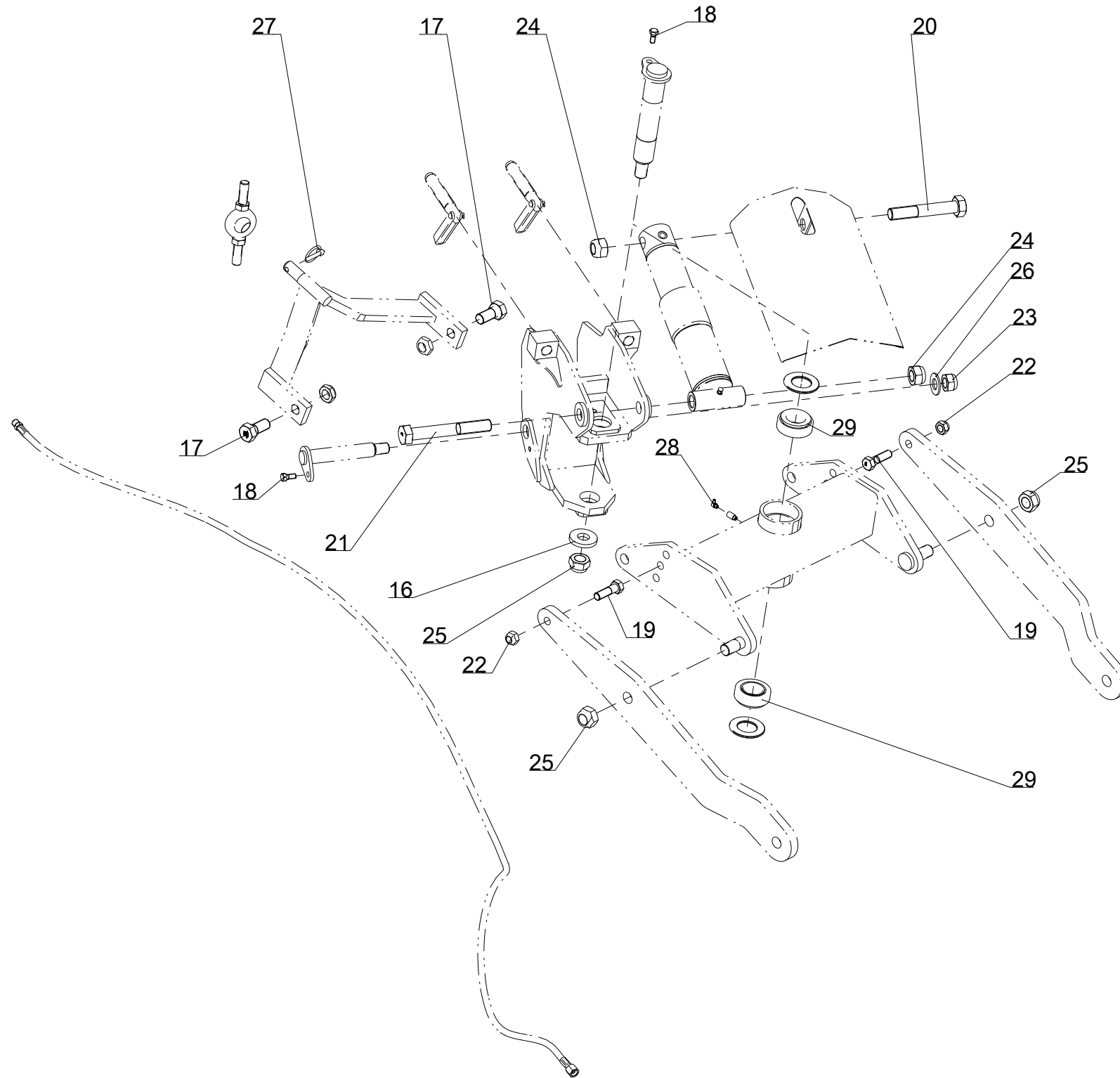

<i>Index</i>	<i>Quantite</i>	<i>Reference</i>	<i>Designation</i>
16	1	5GB122 106	Special washer - 30.5x70x10
17	2	5GB122 265	Screw H M27x 60 - 10.9 Znbl, thread /45mm, thread200
18	2	5GBVI 24 33	Screw H conical M12x22 lg. : 36
19	2	5GBVI 33 06	Screw H M20x 70 - 8.8 ZNBL
20	1	5GBVI 37 02	Screw H M30x180 - 8.8 ZNBL
21	1	5GBVI 37 04	Screw H M30x220 - 8.8 ZNBL
22	2	5GBVJ 327	Nyloc nut std H M 20 - 8 ZNBL
23	1	5GBVJ 333	Nyloc nut std H M 27 - 8 ZNBL - thread 200
24	2	5GBVJ 334	Nyloc nut std H M 30 - 8 ZNBL
25	3	5GBVJ 335	Nyloc nut std H M 30 - 8 ZNBL - thread 200
26	1	5GBVK 512	Flat washer MU27 ZNBL
27	1	5GBVL 103	Lynch pin "Clips" Dia10 Z
28	1	5GBVM 203	Grease nipple 90° M8x125
29	2	5GBVN 33 210	Taper roller bearing



Wheel 1115 16.0/70-20, Single wheel, 8 hole

Index	Quantite	Reference	Designation
1	1	5GB1 292 195_JDT	Kit - Wheel hub, 8 studs
2	1	5GB198 734 DYT	Cplt wheel - 16.0/70-20 TL AS504,8 studs, R.H. tractor, Yellow rim

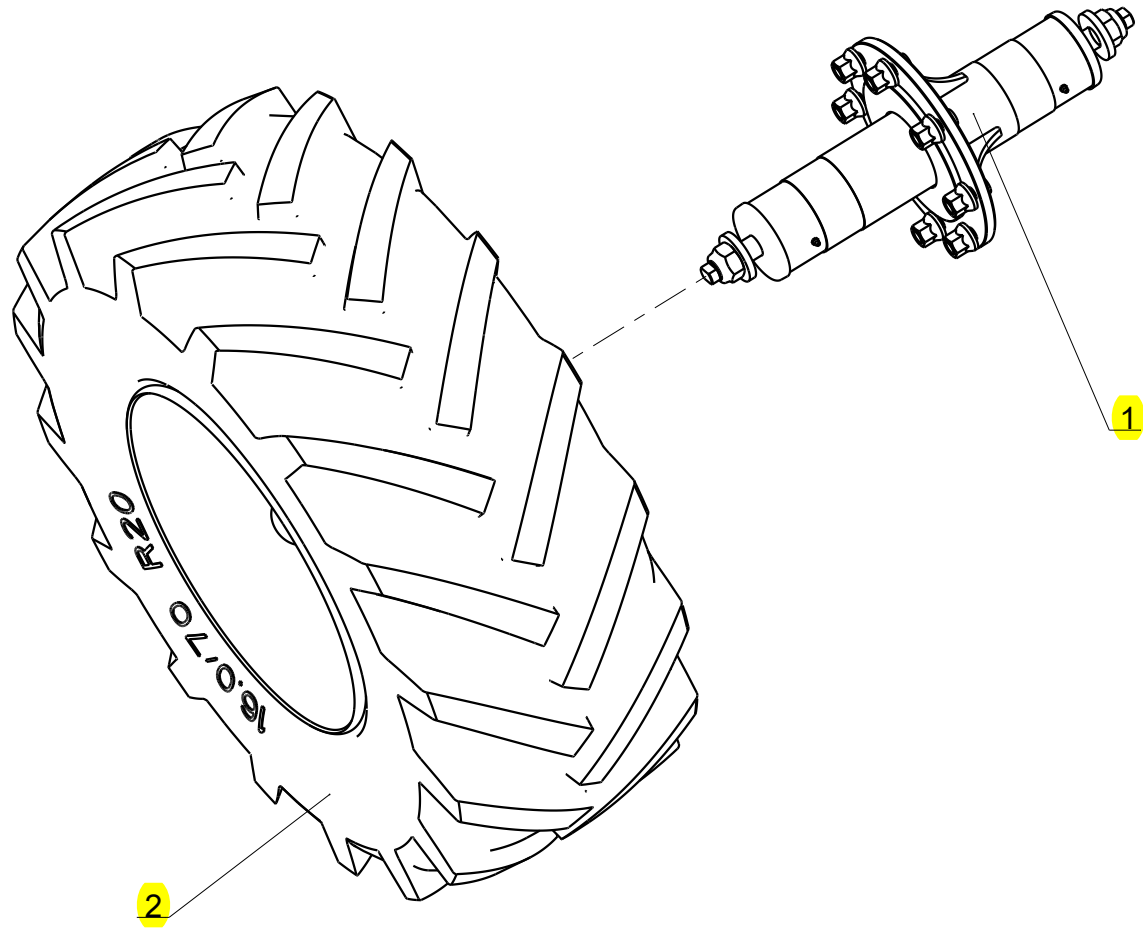

Hydraulic Suspension on Wheel
Гидравлическая подвеска на колесе

PY57573 A.1

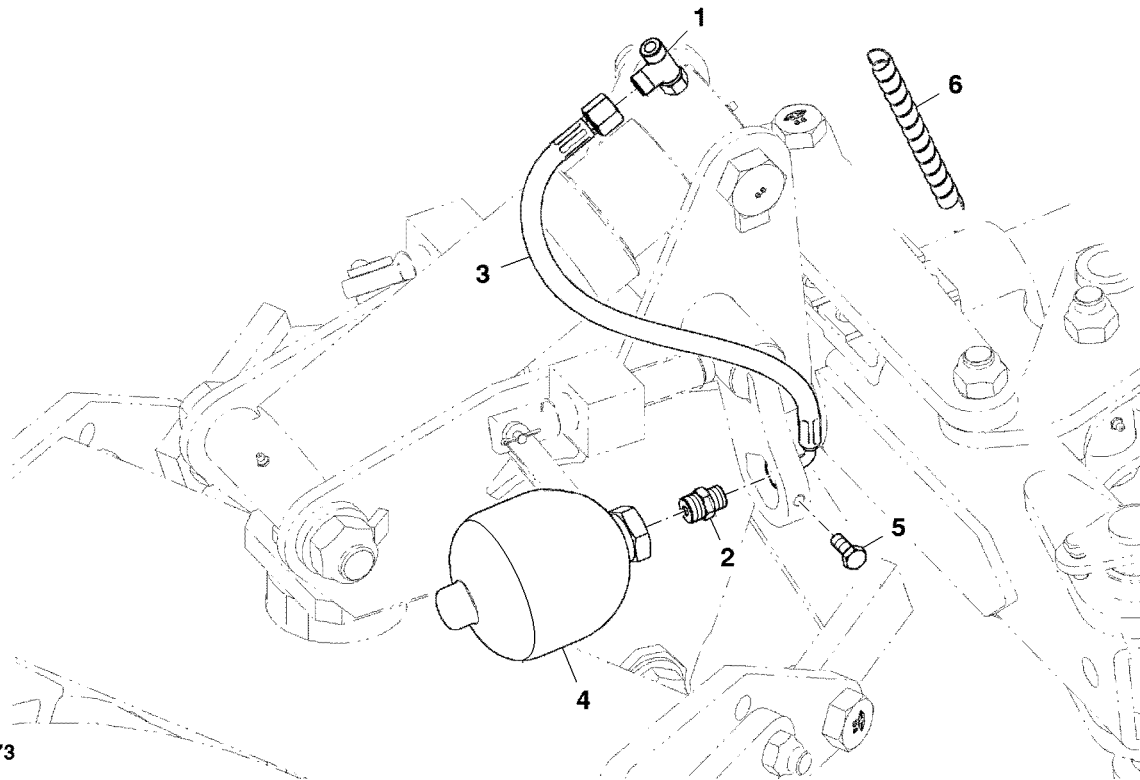

PY57573

Key	Part No.	Part Name	Qty.	Serial No.	Remarks
1	5GB1112972	Fitting	1		M12
2	5GB1116509	Union Fitting	1		M12
3	5GB1223130	Hose	1		
4	5GB1233105	Accumulator Kit	1		
5	5GBV12105	Screw	1		M10 X 25
6	5GB1116581	Spring	1		Hose Protector, OD 15 mm
	5GB1116582	Spring	1		Hose Protector, OD 20 mm
	5GB1116580	Spring	1		Hose Protector, OD 13 mm
	5GB1116546	Spring	1		Hose Protector, OD 25 - 40 mm

P
R
O
O
F

P
R
O
O
F

P
R
O
O
F



Securite boulon cisaillement RABE / SP9

Shearbolt protection

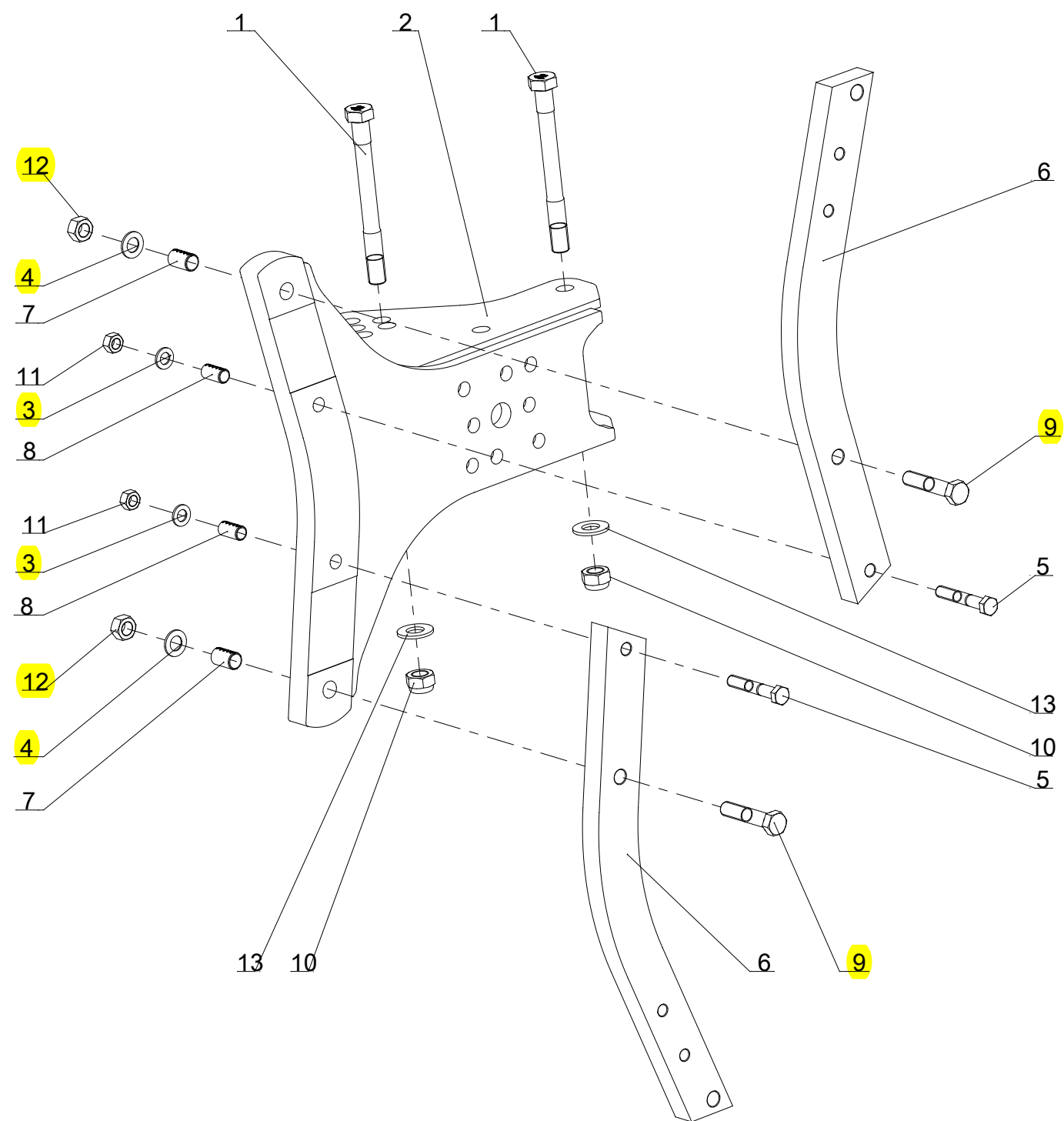

Index	Quantité	Reference	Designation
1	2	5GB1 118 358	Screw H M24x240 - 10.9 ZNBL, thread /36 mm
2	1	5GB1 118 468	console
3	2	5GB6916D17A	Washer 17 EN14399-6 Z
4	2	5GB6916D21A	Washer 21 Z
5	2	5GB7001.24.00	Hex. Screw M16x1.5x100 with Notche
6	2	5GB7010.03.01	Leg RH 800, 70x35
7	2	5GB7010.03.02	Steel bushing Ø 24 x 20 x 38
8	2	5GB7010.03.03	Steel bushing Ø 20 x 16 x 38
9	2	5GBVI 33 41	Screw H M20x100 - 12.9 ZNBL, thread150
10	2	5GBVJ 331	Nyloc nut std H M 24 - 8 ZNBL
11	2	5GBVJ 638	Nut HU M16 - 8 ZNBL - thread 150
12	2	5GBVJ 639	Nut HU M20 - 10 ZNBL - thread 150
13	2	5GBVK 510	Flat washer MU24 ZNBL

Key	Part No.	Part Name	Qty.	Serial No.	Remarks
1	5GB27510101	Frog	1		RH
	5GB27510102	Frog	1		LH
2	5GB27510501	Shin	1		RH
	5GB27510502	Shin	1		LH
3	5GB27510401	Ripper	1		RH
	5GB27510402	Ripper	1		LH
4	5GB27002603	Screw	10		M12 X 30
5	5GB27513001	Plow Share	1		RH
	5GB27513002	Plow Share	1		LH
6	5GB27002605	Screw	18		M12 X 35
7	5GB27510305	Landside	2		
8	5GB64366003	Washer	4		
9	5GB934D16PA	Nut	4		M16
10	5GB27002614	Screw	2		M12 X 75
11	5GB934D12M	Nut	30		M12
12	5GB1481D2145	Pin	2		
13	5GB22044908	Bolt	2		M16 X 75
14	5GB22044905	Bolt	2		M16 X 65
15	5GB27010101	Eyebolt	2		

DRAFT
OFF PROOF

Plain Body (2/2)
 Простой корпус (2/2)

PY57576 A.1

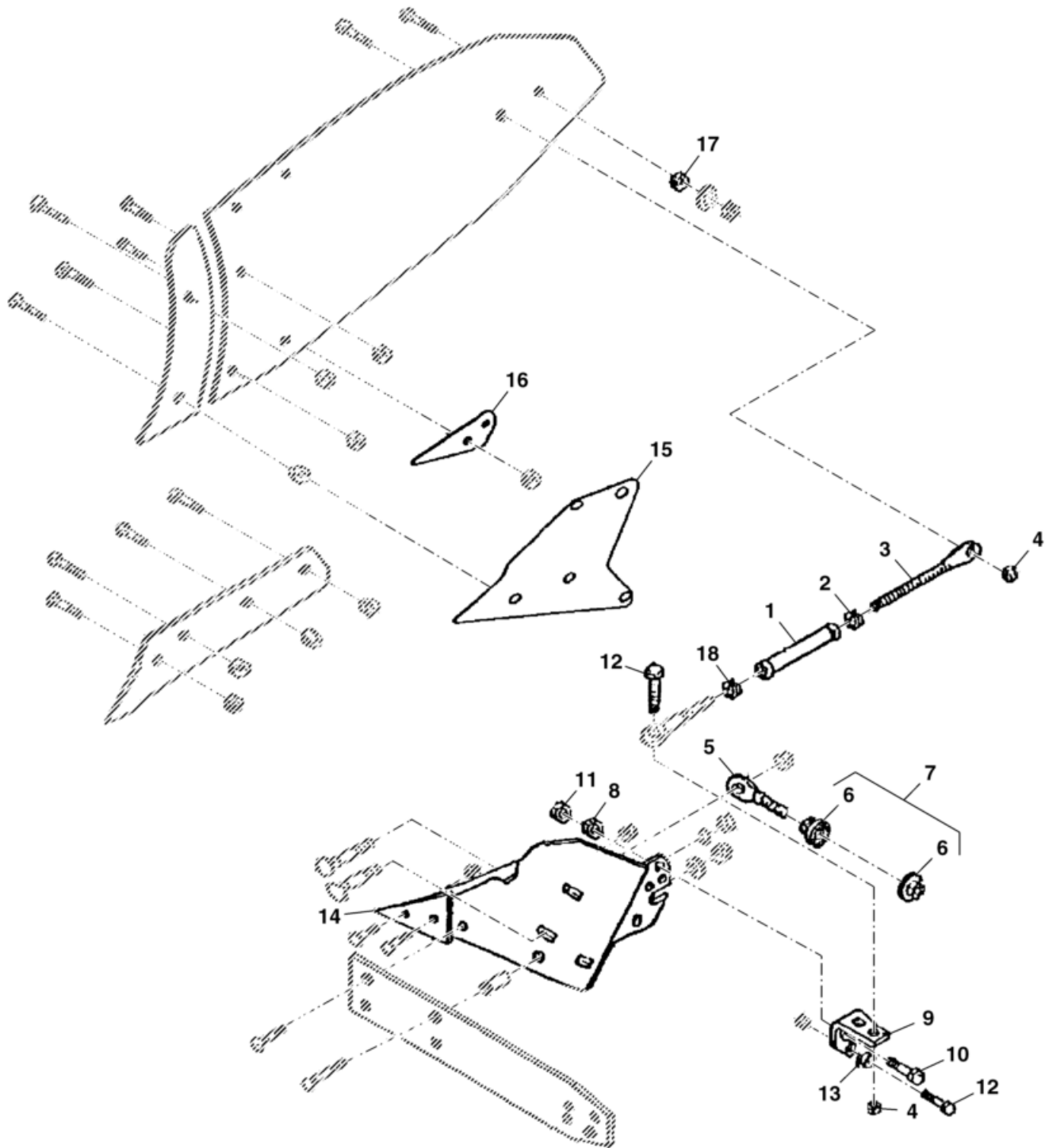

PY57576

Key	Part No.	Part Name	Qty.	Serial No.	Remarks
1	5GB27010300	Nut	2		
2	5GB934D24P	Nut	2		M24
3	5GB27010101	Eyebolt	2		
4	5GB980DV12NA	Lock	4		
5	5GB27200701	Screw	2		M20
6	5GB934D20N	Nut	4		M20
7	5GB27201101	Washer	4		
8	5GB127DB20A	Spring Washer	2		
9	5GB27200605	Bracket	1		RH
	5GB27200606	Bracket	1		LH
10	5GBVI2826	Screw	2		M20 X 45
11	5GB934D20PA	Nut	2		M20
12	5GBVI2829	Screw	4		M12 X 40
13	5GB126D14	Washer	2		
14	5GB27510205	Point	2		
15	5GB27512000	Shim	4		
16	5GB27510001	Steel	2		
17	5GB27200500	Washer	2		
18	5GB934D24PL	Nut	2		M24

DRAFT
OFF
PROOF

Option Share + Point
Опция Share + Point
PY57579 A.1

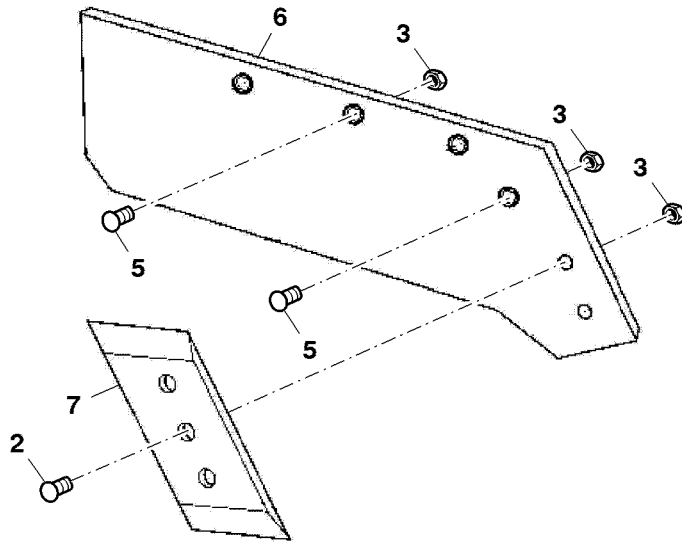
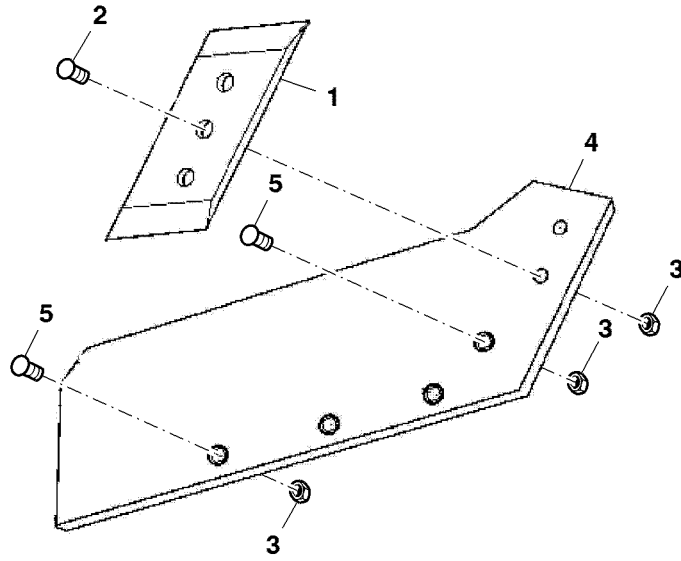

PY57579



Key	Part No.	Part Name	Qty.	Serial No.	Remarks
1	5GB27510902	Point	1		LH
2	5GB27004114	Bolt	4		M12 X 40
3	5GB934D12M	Nut	12		M12
4	5GB27512202	Plow Share	1		LH
5	5GB27002605	Screw	8		M12 X 35
6	5GB27512201	Plow Share	1		RH
7	5GB27510901	Point	1		RH

P
R
O
O
F
P
R
O
O
F

Extension Mouldboard BP351W
Удлинитель отвала BP351W

PY57651 A.1

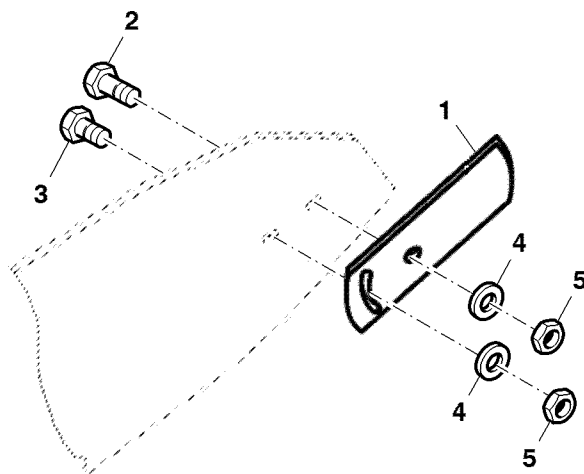

PY57651

Key	Part No.	Part Name	Qty.	Serial No.	Remarks
1	5GB27011901	Extension	1		RH
	5GB27011902	Extension	1		LH
2	5GB27002603	Screw	2		M12 X 30
3	5GB27002610	Screw	2		M12 X 55
4	5GB27200500	Washer	4		
5	5GB980DV12NA	Lock	4		

Vari - Fix Skimmers Model 212B
 Предплужники Vari-Fix модели 212B

PY57580 A.1

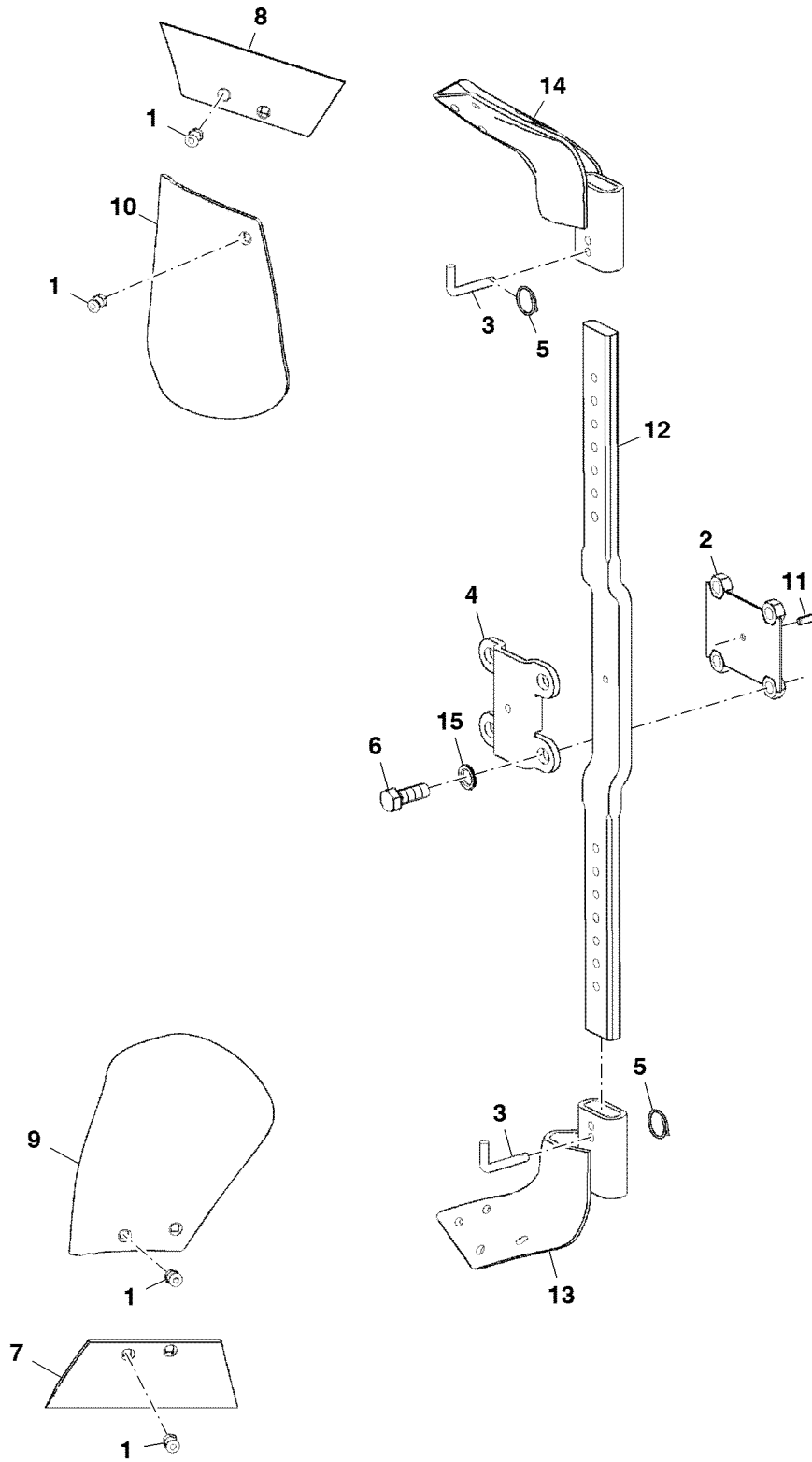

PY57580



Key	Part No.	Part Name	Qty.	Serial No.	Remarks
1	5GBVI1314	Screw	8		
2	5GB27544001	Lock	1		
3	5GB62412902	Pin	2		
4	5GB27542602	Plate	1		
5	5GB66081207	Clip	2		
6	5GBVI2825	Screw	4		M20 X 55
7	5GB27150502	Plow Share	1		LH
8	5GB27150501	Plow Share	1		RH
9	5GB27150702	Shin	1		LH
10	5GB27150701	Shin	1		RH
11	5GB1481D1030	Spring	1		
12	5GB27543001	Shaft	1		
13	5GB27542902	Frog	1		LH
14	5GB27542901	Frog	1		RH
15	5GB6916D21A	Washer	4		

D
R
O
O
F

P
R
O
O
F

Rear lighting kit, M20

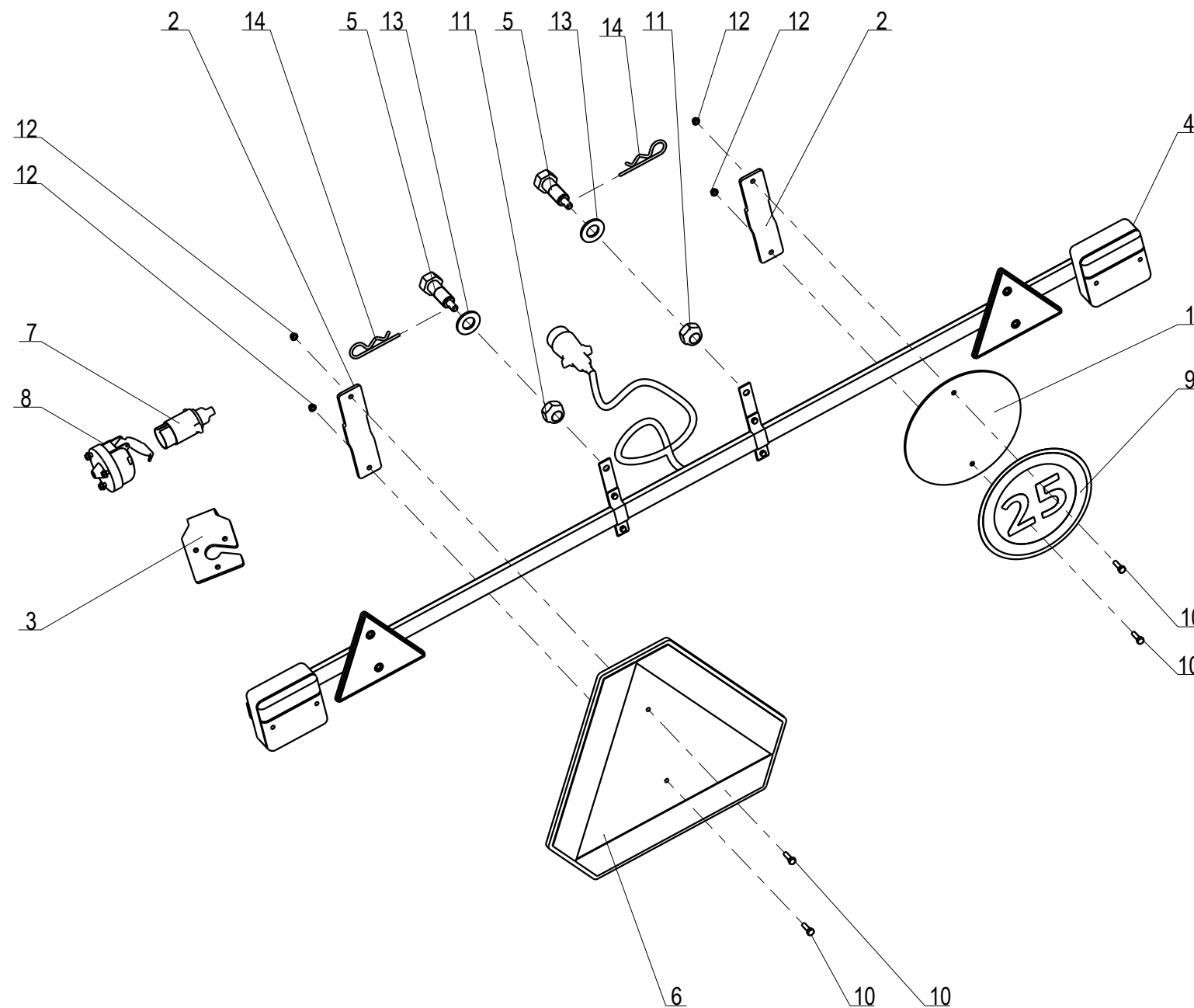
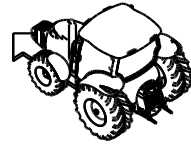

Repere	Quantité	Reference	Designation
1	1	5GB1 214 186	Support Adhesive 25km/h
2	2	5GB1 214 192	Flange
3	1	5GB1 214 198	7 pin plug holder
4	1	5GB1 214 199	Rear trailer board
5	2	5GB1 291 128	Special screw for lighting board H M20x70
6	1	5GB6103.16.65	triangle signaling
7	1	5GB850 100 385	Male electrical outlet
8	1	5GB850 101 785 A	Electrical outlet, 7 pin, female
9	1	5GB9998.25.04	Adhesive 25km/h Russia
10	4	5GBVI 26 03	Screw H M6x 20 - 8.8 ZNBL
11	2	5GBVJ 327	Nyloc nut std H M 20 - 8 ZNBL
12	4	5GBVJ 340	Nyloc nut std H M 6 - 8 ZNBL
13	2	5GBVK 508	Flat washer MU20 ZNBL
14	2	5GBVL 002	R Clip - 4, Z



Rear trailer board

Index	Quantite	Reference	Designation
1	1	5GB1 122 765	7-Pin plug
2	2	5GB1 221 234	Signal lantern
3	1	5GB1 231 229	Electrical outlet, 7 pin, female
4	2	5GBM 670 111	Red triangular reflector

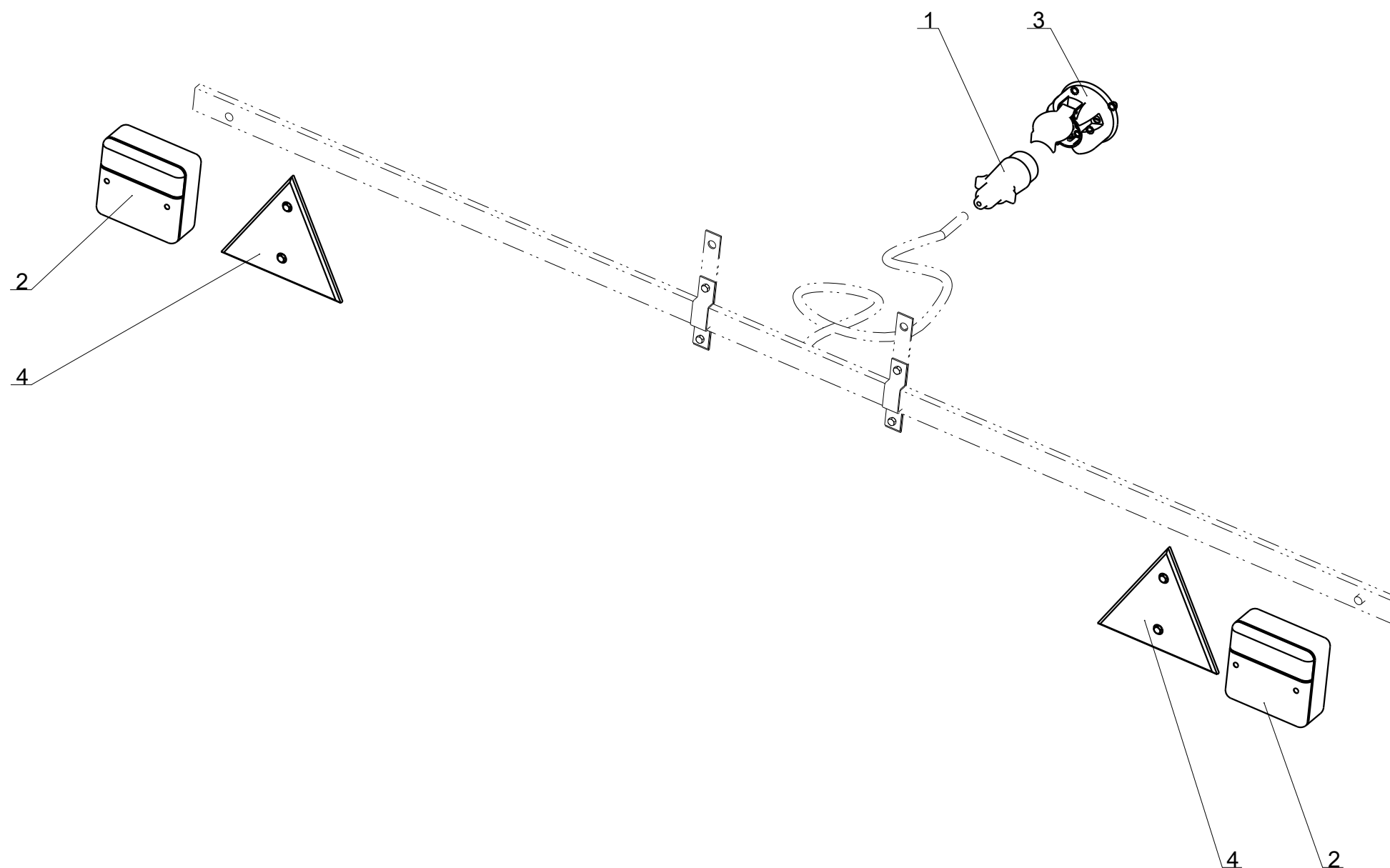

Stickers for ploughs 3810F

Safety stickers

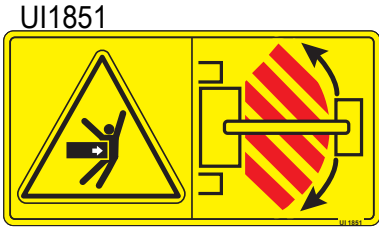

Informations stickers

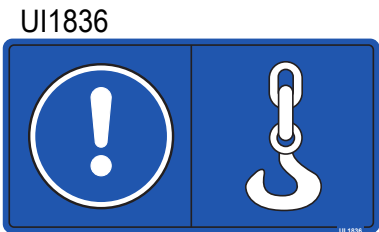
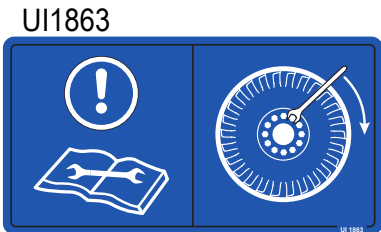

Stickers for ploughs 3810F

Stickers

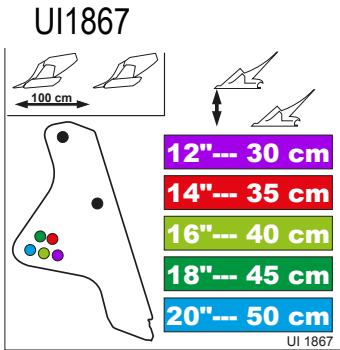

48059232



3810 "In Furrow" models (Left side)

48059200 6-furrows



48059201 7-furrows



48059202 8-furrows



48059203 9-furrows



3810 "In Furrow" models (Right side)

48059204 6-furrows



48059205 7-furrows



48059206 8-furrows



48059207 9-furrows



Complete kit stickers 5 & 6 furrows: 48059101

Complete kit stickers 7 furrows : 48059105

Complete kit stickers 8 furrows : 48059108

Complete kit stickers 9 furrows : 48059109