

--	--	--	--	--	--	--	--

		/					
--	--	---	--	--	--	--	--



Important pour la commande de pièces de rechange

Lors de chaque commande de pièces, veuillez nous communiquer les données suivantes:

1. Type de la machine (gravé sur la plaque d'identification).
2. Numéro de série de la machine (gravé sur la Plaque d'identification et le bâti).
3. Numéro de pièce.
4. La quantité nécessaire de pièces de rechange.

Important for ordering spare parts

Please give the following information whenever you order spare parts:

1. Type of the machine (stamped on type plate)
2. Serial number (stamped on type plate and frame)
3. Part number.
4. The required quantity of the spare parts.

Plaquette / Identification plate



Sommaire

Avant-Train fixe D2D3 L2.....	7
Valve Push-Pull M18x15 a clapet	9
Caisson charrue	10
Securité boulon console.....	11
Tendille 70x30 RH80 cpl.	12
Vis de fixation cpl. T30 D16/20	13
Kit de visserie pour tendille(épaisse 30) cpl.....	14
Corps de labour	15
Corps a versoirs claire-voie.....	18
Défecteur DG-52 R.....	21
Défecteur DG-52 L	22
Défecteur DG-51 UR	23
Défecteur DG-51 UL.....	24
Rasette Vari-Fix 200 B cpl.	25
Console avec roue	26

Table of contents/

Headstock D2D3 L2	7
Hydraulic connector M18x15 a.....	9
Plough Frame.....	10
Console	11
Etancon 70x30 RH80 cpl.	12
Mounting screws cpl.-(Parts Kit)	13
Screw Kit fort he Leg(thickness 30)cpl.-(Parts Kit.....	14
Body BP 322 P	15
Slatted body BP 331 WS.....	18
Trashboard DG-52 R.....	21
Trashboard DG-52 R.....	22
Trashboard DG-51 UR	23
Trashboard DG-51 UL.....	24
Skimmer Varifix 200 B cpl.	25
Console with wheel	26



Avant-Train fixe D2D3 L2 Headstock

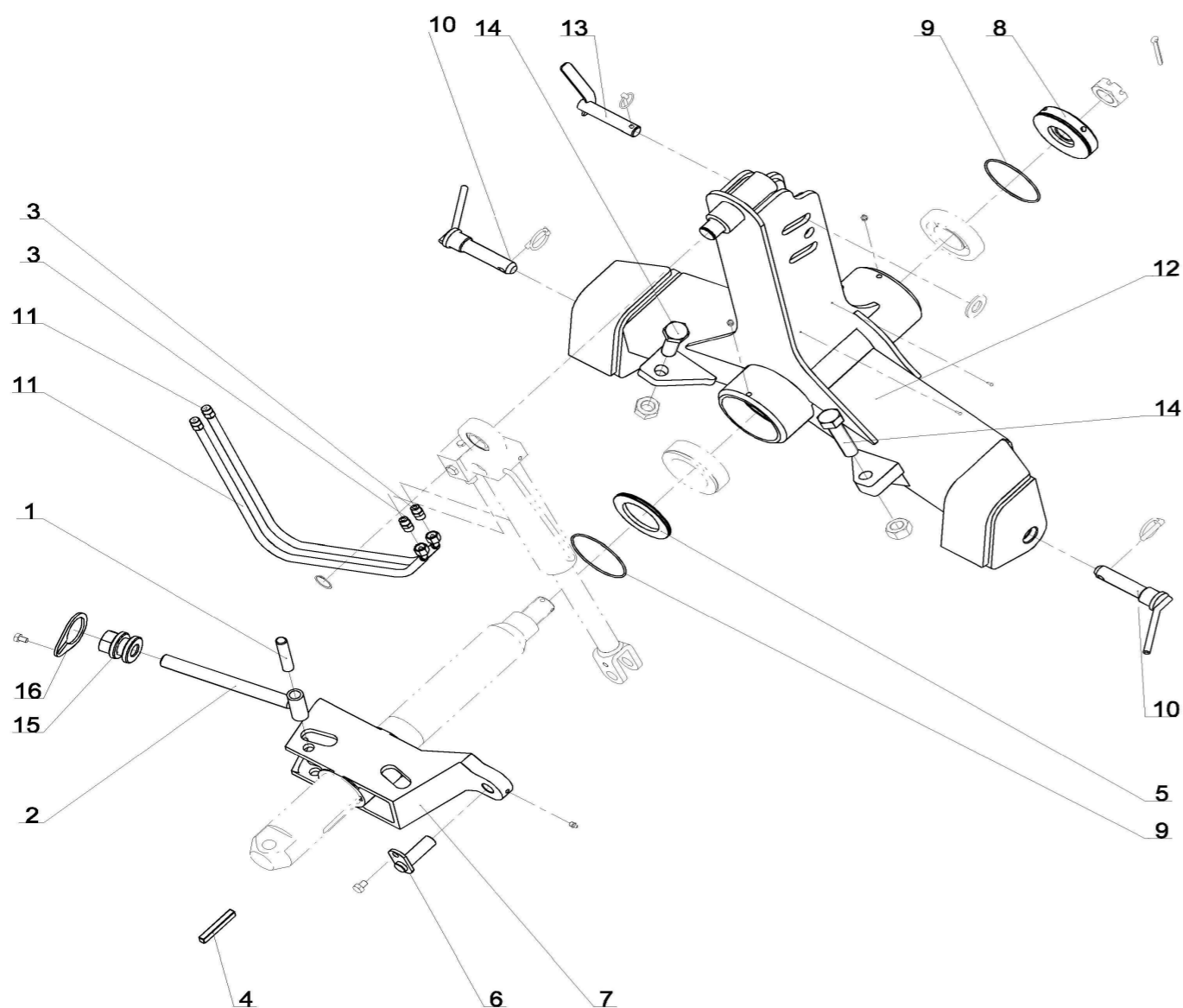

Repere	Quantite	Reference	Designation
1	1	1 112 410	Axe de vis de réglage lateral Axle (lateral adjusting screw)
2	1	1 112 719	Vis réglage lateral RH80 Lateral adjusting screw RH80
3	2	1 116 363	Union nu male12 + male3/8 Cyl Union M12 + M3/8 Cyl
4	1	1 122 001	Clavette de fusee RH90-RH110 Shaft wedge RH90-RH110
5	1	1 122 019	Rondelle butee RH90 Stop washer RH90
6	1	1 122 307	Axe inferieur verin Pin (ram) RG
7	1	1 122 308 U	Porte fusee RH90 Shaft support RH90
8	1	1 122 318	Ecrou de fusee RH90 Seal carrier front RG35 RH90
9	2	1 122 372	Joint torique 120x3,5 / D:130 O-Ring 120x3,5 / D:130
10	2	1 122 717	Broche d'attelage fixe N°2 Fixed link pin N°2
11	2	1 123 113	Flex. Hyd. - Dia 5/16", Lg.:1500mm, E12 a 45°-MVA18 Hydraulic hose - Dia 5/16", Lg.:1500mm, E12 45° - MCA18
12	1	1 123 401	Avant train Headstock
13	1	1 123 402	Broche 3em Point Avt-Train Top link pin (headstock)
14	2	1 123 405	Vis H M27x100 8.8 Z Filt. total (inclinaison) Inclination adjusting bolt H M27x100 8.8 Z full thread
15	1	1 123 414	Guide de réglage deport Guide (front furrow adjustment)
16	1	1 123 415	Rondelle de guidage deport Guide washer (front furrow adjustment)



Avant-Train fixe D2D3 L2

Headstock

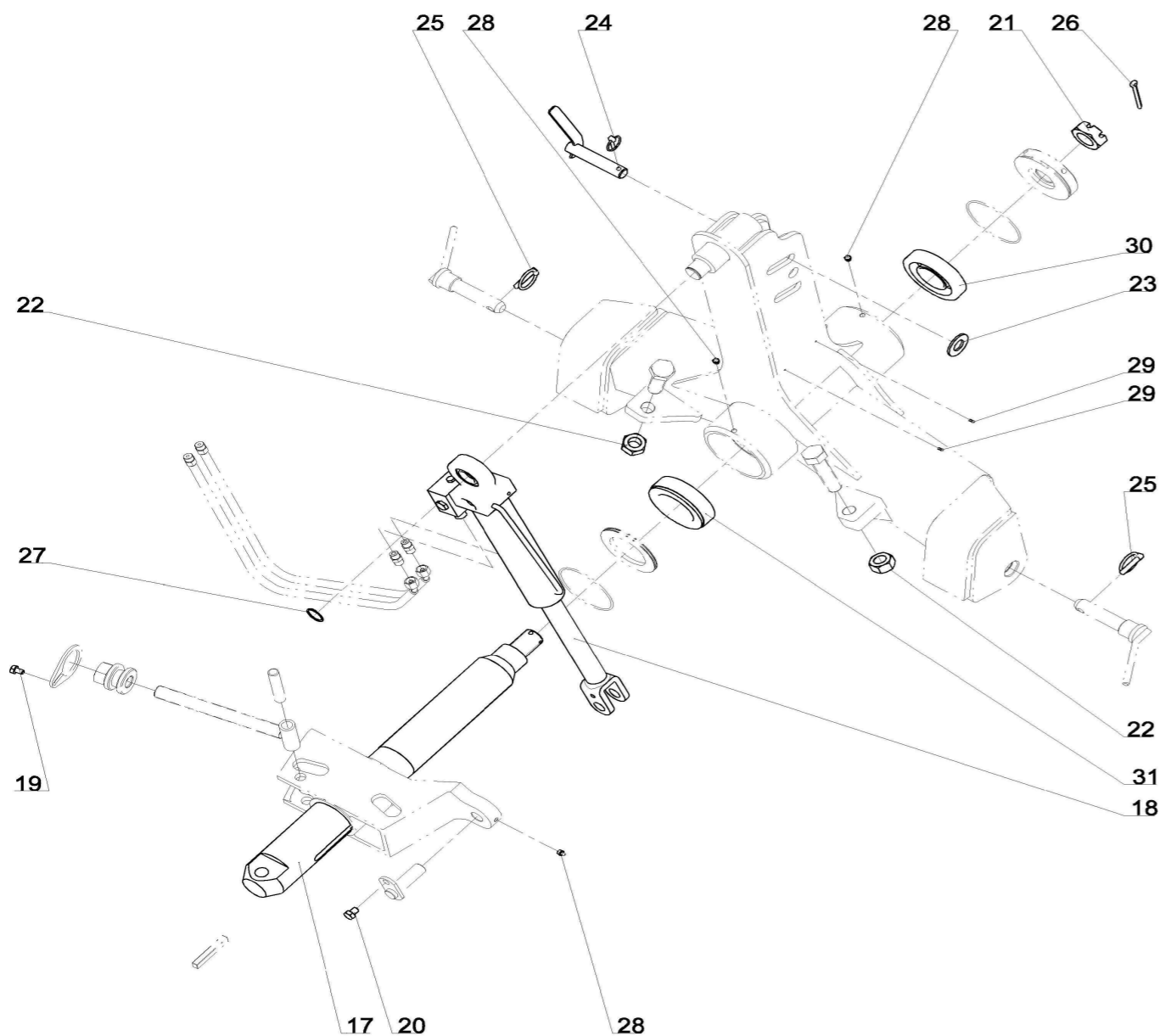

Repere	Quantite	Reference	Designation
17	1	1 123 417	Fusee Avant-Train Headstock shaft
18	1	1 123 418	Verin de retournement Dia 63x40 C255 Turnover ram Dia. 63x40 Stroke 255
19	1	VI 28 01	Vis H M10x16 - 8.8 Z, filet / 16 mm Screw H M10x16 - 8.8 Z, thread / 16 mm
20	1	VI 29 01	Vis H M12x16 - 8.8 Z, filet / 16 mm Screw H M12x16 - 8.8 Z, thread / 16 mm
21	1	VJ 210	Ecrou a crenaux HK M 40x 300 Castellated nut HK M 40x 300
22	2	VJ 623	Ecrou std H M27 - pas 300 Noir Nut std H M27 - thread 300 Noir
23	1	VK 512	Rondelle plate moyenne MU27 Washer MU 27
24	1	VL 101	Goupille Clips Dia6 Lynch pin Dia6
25	2	VL 103	Goupille Clips Dia10 Lynch pin Dia10
26	1	VL 419	Goupille fendue V 8x80 Split pin V 8x80
27	1	VM 007	Circlips exterieur pour arbre Dia 35 mm Outer snap ring for shaft Dia 35 mm
28	3	VM 205	Graisseur droit - M10, pas150 Grease nipple - M10, thread150
29	2	VM 410	Rivet tete ronde 4x9 Round-head rivet 4x9
30	1	VN 30 312	Roulement a rouleaux conique Dia60x130x34 Taper roller bearing Dia60x130x34
31	1	VN 33 017	Roulement a rouleaux conique Dia85x130x36 Taper roller bearing Dia85x130x36



Valve PUSH-PULL M18x15 a clapet
Hydraulic connector M18x15 a



<i>Repere</i>	<i>Quantite</i>	<i>Reference</i>	<i>Designation</i>
1	1	1 122 393	Valve a pousse M18 X 15O male Automatic valve Push-pull M18x15O

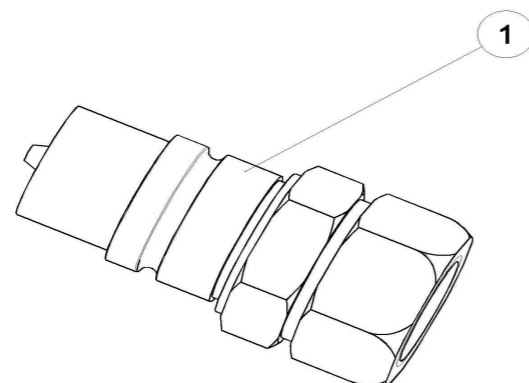



Caisson charrue
Plough Frame

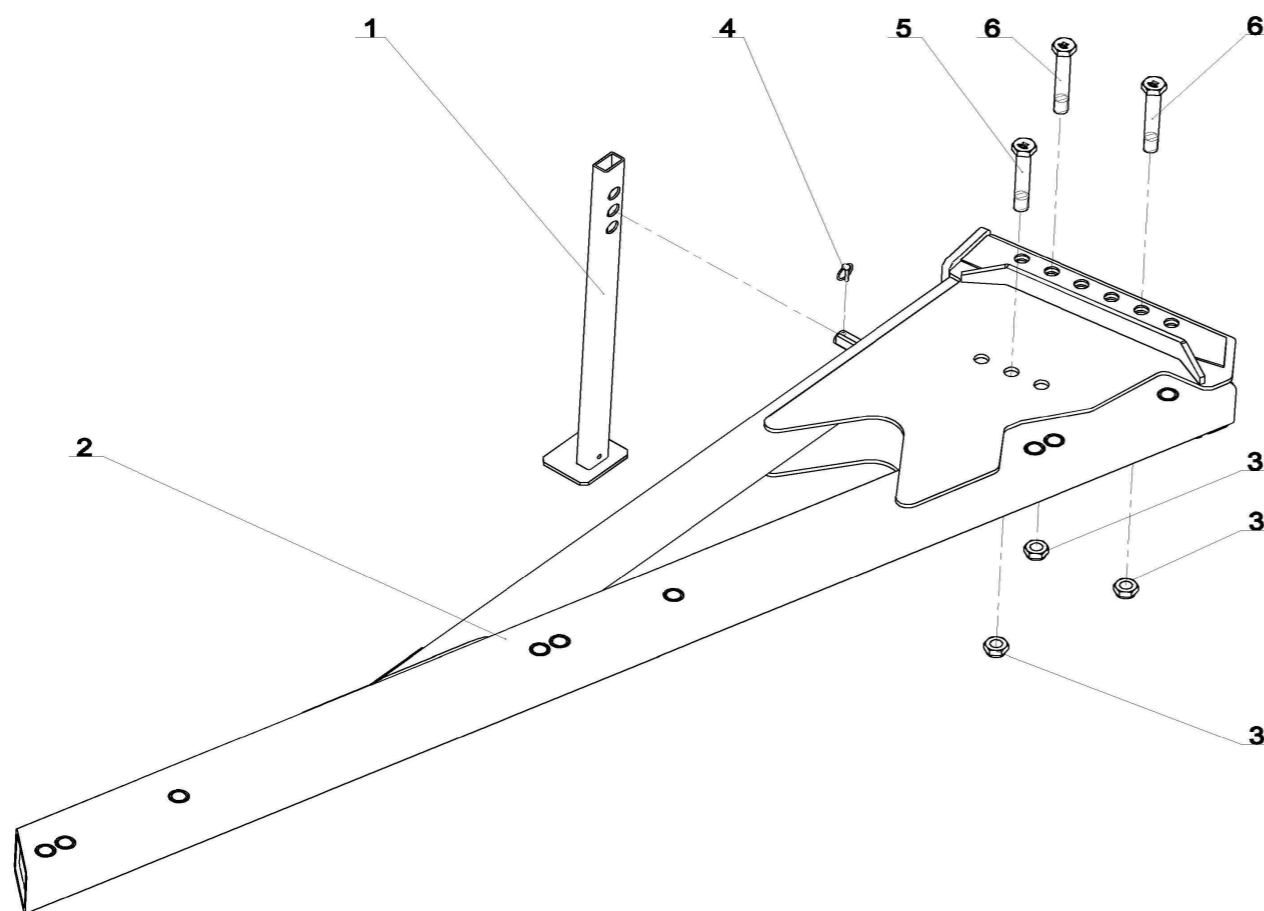

<i>Repere</i>	<i>Quantite</i>	<i>Reference</i>	<i>Designation</i>
1	1	1 123 408	Bequille charrue Parking leg / plough
2	1	1 123 403	Caisson 3 Corps 1000 Main beam 3-furrow 1000
-	1	1 123 420	Caisson 4 Corps 1000 Main beam 4-furrow 1000
3	3	VJ 331	Ecrou frein std H M 24 - pas 300 Nyloc nut std H M 24 - thread 300
4	1	VL 101	Goupille Clips Dia6 Lynch pin Dia6
5	1	VI 35 15	Vis H M24x170 - 10.9 Z, filet / 36 mm Screw H M24x170 - 10.9 Z, thread / 36 mm
6	2	VI 35 17	Vis H M24x180 - 10.9 Z, filet / 36 mm Screw H M24x180 - 10.9 Z, thread / 36 mm



Securité boulon console
Console



Repere	Quantite	Reference	Designation
1	2	1 118 356	Vis H M24x180 - 10.9 ZNBL, filet /36 mm Screw H M24x180 - 10.9 ZNBL, thread /36 mm
2	1	4814.00.01	console console welded
3	2	VJ 331	Ecrou frein std H M 24 - 8 ZNBL Nyloc nut std H M 24 - 8 ZNBL

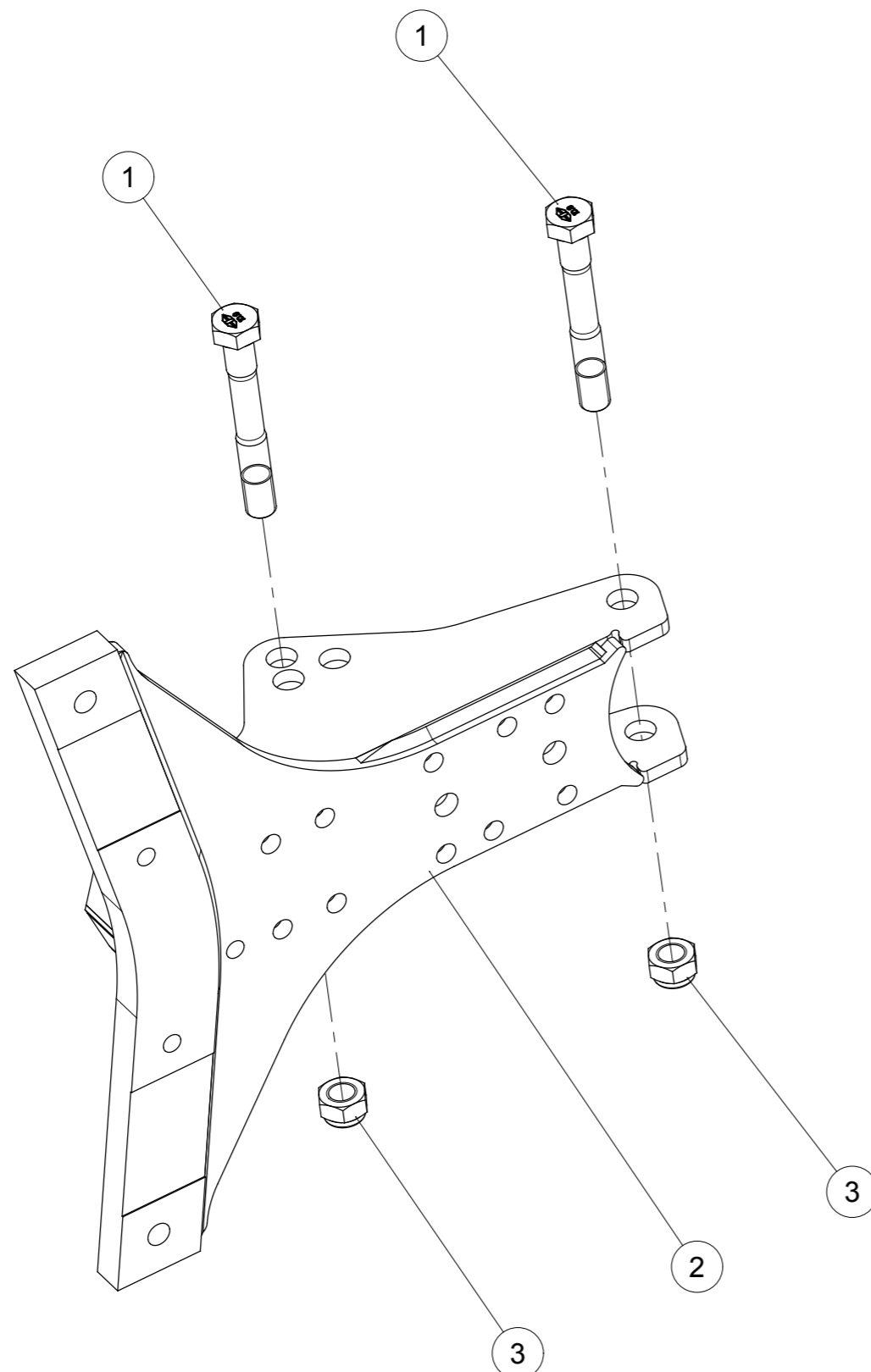



TENDILLE 70x30 RH80 CPL.
ETANCON 70x30 RH80 CPL.



7010.04.01 Mounting screws cpl.-(Parts Kit)

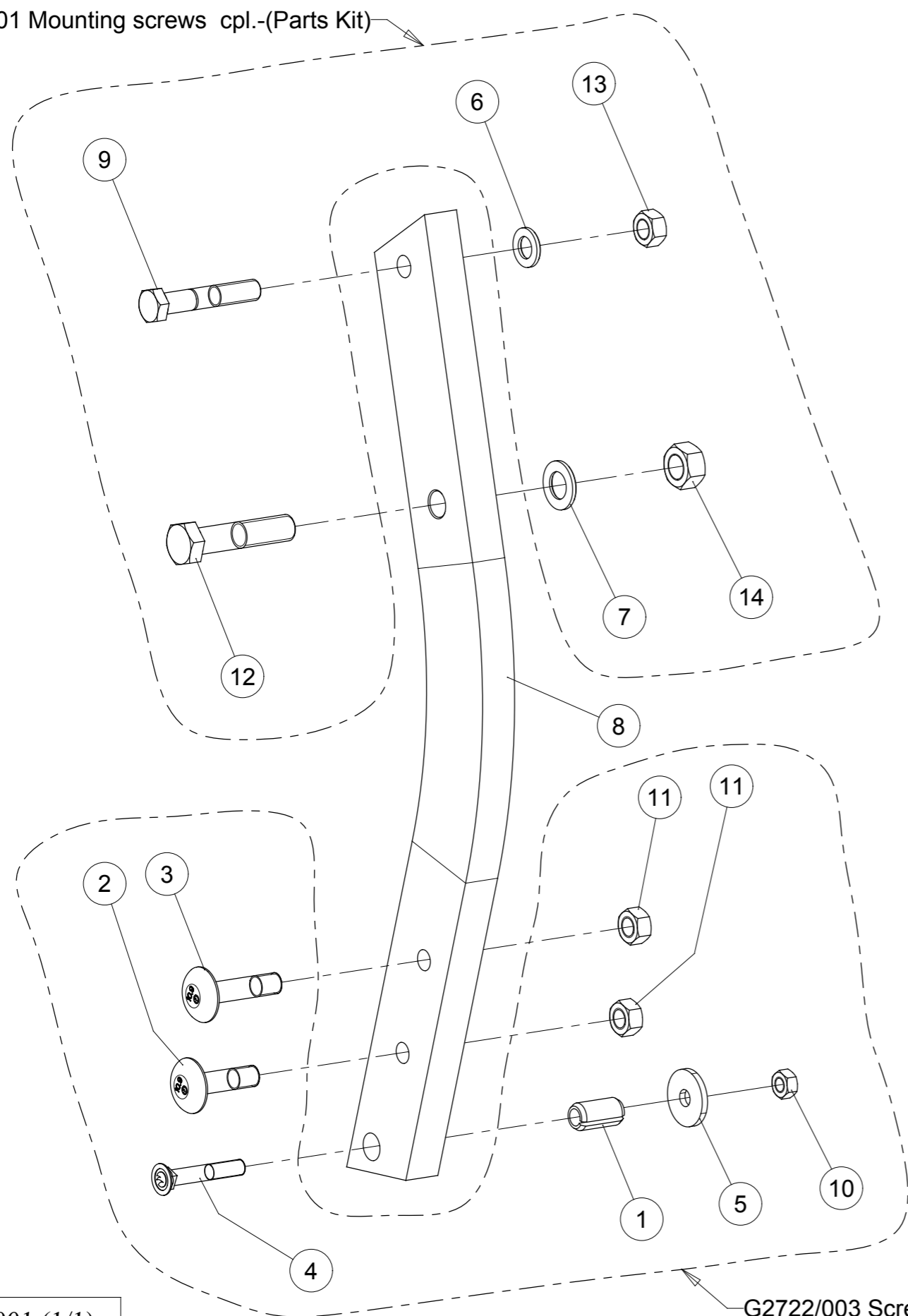

Repere	Quantite	Reference	Designation
1	1	1481D2140	Goupille elastique 21 X 40 ISO8752 Spring Pin 21 X 40 ISO8752
2	1	2204.49.03	Vis M 16x60-10.9 Bolt M 16x60-10.9
3	1	2204.49.12	Vis M 16x70-10.9 Bolt M 16x70-10.9
4	1	2700.26.14	Vis a tête fraisée M 12 X 75-10.9 C sunk screw M 12 X 75-10.9
5	1	6436.60.03	Rondelle C-13 Washer C-13
6	1	6916D17A	Rondelle 17 EN14399-6 Z Washer 17 EN14399-6 Z
7	1	6916D21A	Rondelle 21 Z Washer 21 Z
8	1	7010.01.01	Etancon 70x30 RH80 Leg 70x30 RH80
9	1	7010.02.01	Vis Hex.M16x1.5x90 - 10.9 avec entaille Hex Screw M16x1.5x90 - 10.9 with Notche
10	1	934D12M	Ecrou std H M12 - pas 175 Noir Nut std H M12 - thread 175 Noir
11	2	934D16NA	Ecrou std H M16 - pas 200 Zingue Nut std H M16 - thread 200 Zingue
12	1	960D201590NA	Vis hex. M20x1.5x90 ZNBL Hex. Screw M20x1.5x90 ZNBL
13	1	VJ 638	Ecrou HU M16 - 8 ZNBL - pas 150 Nut HU M16 - 8 ZNBL - thread 150
14	1	VJ 639	Ecrou HU M20 - 10 ZNBL - pas 150 Nut HU M20 - 10 ZNBL - thread 150

G2722/003 Screw Kit for the Leg (thickness 30) cpl.-(Parts Kit)

G7010/001 (1/1)



Vis de fixation cpl. T30 D16/20
Mounting screws cpl. T30 D16/20

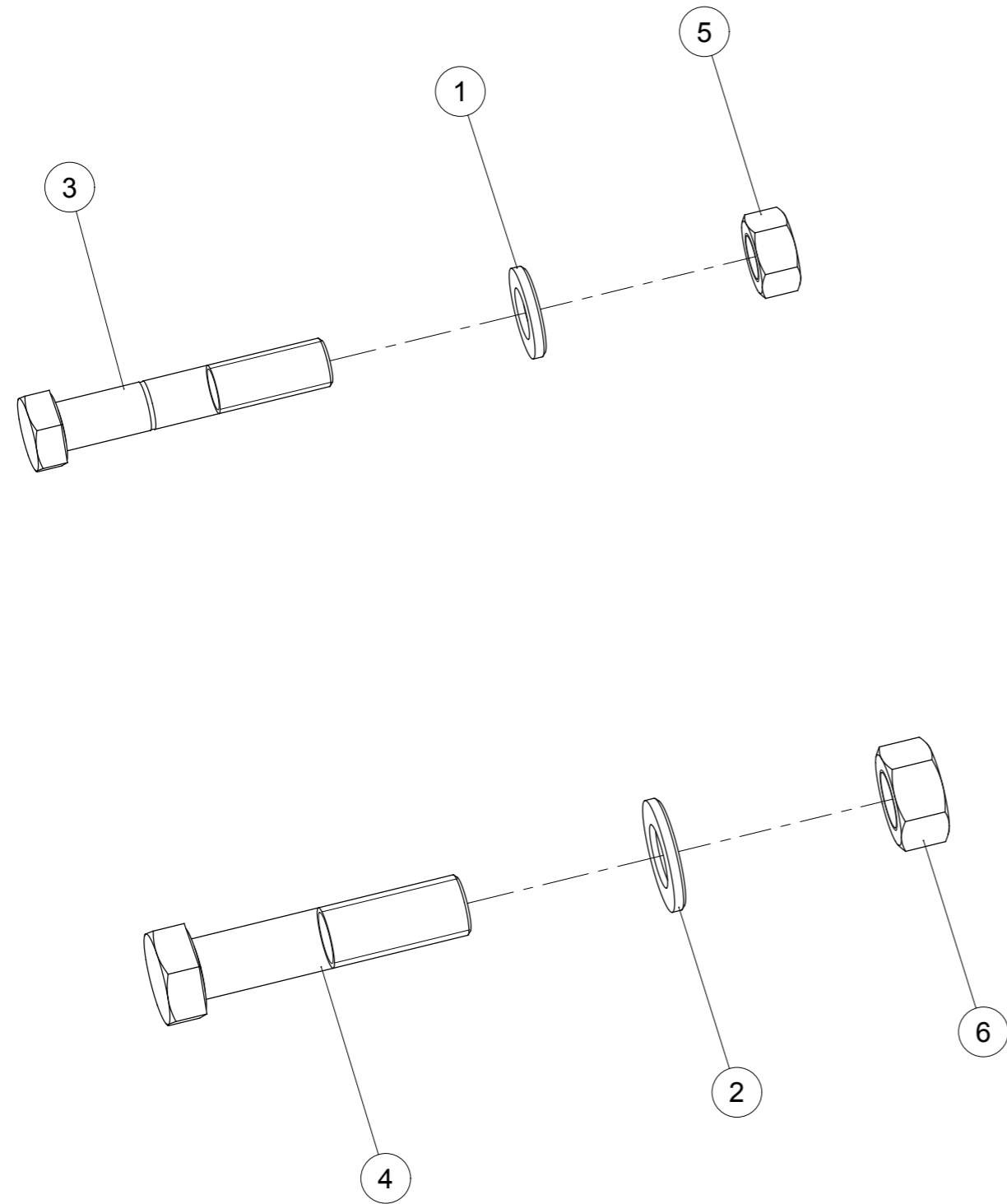

Repere	Quantite	Reference	Designation
1	1	6916D17A	Rondelle 17 EN14399-6 Z Washer 17 EN14399-6 Z
2	1	6916D21A	Rondelle 21 Z Washer 21 Z
3	1	7010.02.01	Vis Hex.M16x1.5x90 - 10.9 avec entaille Hex Screw M16x1.5x90 - 10.9 with Notche
4	1	960D201590NA	Vis hex. M20x1.5x90 ZNBL Hex. Screw M20x1.5x90 ZNBL
5	1	VJ 638	Ecrou HU M16 - 8 ZNBL - pas 150 Nut HU M16 - 8 ZNBL - thread 150
6	1	VJ 639	Ecrou HU M20 - 10 ZNBL - pas 150 Nut HU M20 - 10 ZNBL - thread 150

Kit de visserie pour tendille (épaisse 30) cpl.
Screw Kit for the Leg (thickness 30) cpl.

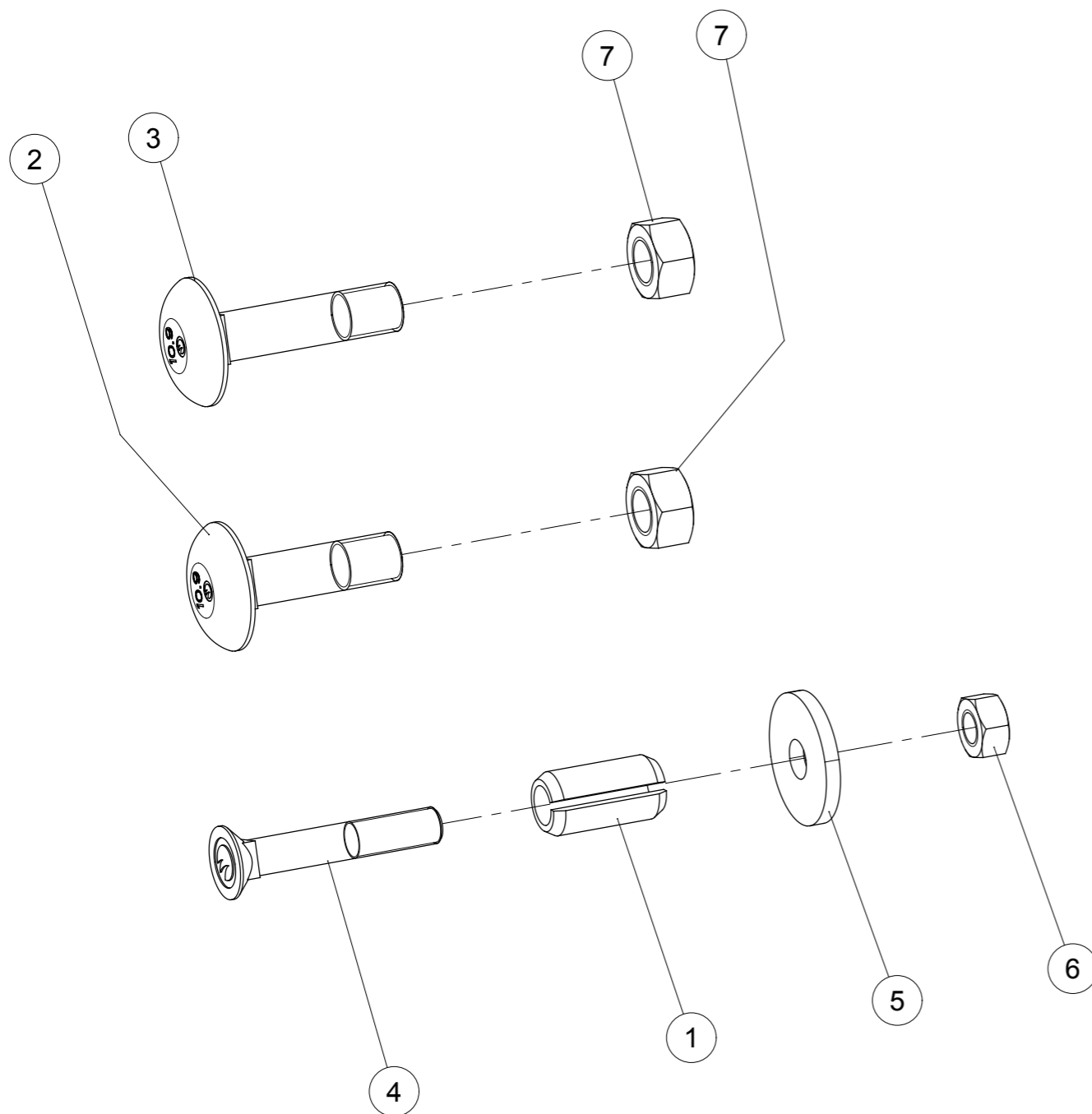

Repere	Quantite	Reference	Designation
1	1	1481D2140	Goupille elastique 21 X 40 ISO8752 Spring Pin 21 X 40 ISO8752
2	1	2204.49.03	Vis M 16x60-10.9 Bolt M 16x60-10.9
3	1	2204.49.12	Vis M 16x70-10.9 Bolt M 16x70-10.9
4	1	2700.26.14	Vis a tête fraisée M 12 X 75-10.9 C sunk screw M 12 X 75-10.9
5	1	6436.60.03	Rondelle C-13 Washer C-13
6	1	934D12M	Ecrou std H M12 - pas 175 Noir Nut std H M12 - thread 175 Noir
7	2	934D16NA	Ecrou std H M16 - pas 200 Zingue Nut std H M16 - thread 200 Zingue



Corps de labour
Body



Bild Ref. Fig.	Bestellnr. Part-No. Référence	Stck. Qty. Qte.	Bezeichnung	Technische Angaben Technical data Données techniques	Description	Désignation
1	2722.02.01	1	Körperbrust	CBP-294 O	Frog	Sep
1	2722.02.02	1	Körperbrust	CBP-294 OL	Frog	Sep
	BP321P		Körper	BP-321 P(L)	Body	Corps de labour
	BP350O		Körper	BP-350 O(L)	Body	Corps de labour
2	2700.54.01	1	Plasma-Schar	SSP-293 OEP	Share	Soc
2	2700.54.02	1	Plasma-Schar	SSP-293 OELP	Share	Soc
2	2700.48.01	1	Schnabelschar	SSP-293 OE	Share	Soc
2	2700.48.02	1	Schnabelschar	SSP-293 OEL	Share	Soc
2	2700.49.01	1	RABID-Schar	SSP-293 OEZ	Share	Soc
2	2700.49.02	1	RABID-Schar	SSP-293 OELZ	Share	Soc
2	2700.11.01	1	Spitzschar	SP-271 P	Share	Soc
2	2700.11.02	1	Spitzschar	SP-271 P L	Share	Soc
2a	2701.11.01	1	Diamantschar	DSP-293 O	Share	Soc
2a	2701.11.02	1	Diamantschar	DSP-293 O L	Share	Soc
	BP322P		Körper	BP-322 P(L)	Body	Corps de labour
	BP351O		Körper	BP-351 O(L)	Body	Corps de labour
2	2700.55.01	1	Plasma-Schar	SSP-294 OEP	Share	Soc
2	2700.55.02	1	Plasma-Schar	SSP-294 OEPL	Share	Soc
2	2707.05.01	1	Schnabelschar	SSP-294 OE	Share	Soc
2	2707.05.02	1	Schnabelschar	SSP-294 OEL	Share	Soc
2	2700.50.01	1	RABID-Schar	SSP-294 OEZ	Share	Soc
2	2700.50.02	1	RABID-Schar	SSP-294 OELZ	Share	Soc
2	2707.02.01	1	Spitzschar	SP-272 P	Share	Soc
2	2707.02.02	1	Spitzschar	SP-272 PL	Share	Soc
3	2701.11.03	1	Unterlage	URP-22 (DSP-293 O/OL)	Shim	Cale
	BP321P		Körper	BP-321 P(L)	Body	Corps de labour
	BP350O		Körper	BP-350 O(L)	Body	Corps de labour
4	2701.33.01	1	Schar für Wechselsp.	SSP-293 OSE	Share	Soc
4	2701.33.02	1	Schar für Wechselsp.	SSP-293 OSEL	Share	Soc
	BP322P		Körper	BP-322 P(L)	Body	Corps de labour
	BP351O		Körper	BP-351 O(L)	Body	Corps de labour
4	2707.04.01	1	Schar für Wechselsp.	SSP-294 OSE	Share	Soc
4	2707.04.02	1	Schar für Wechselsp.	SSP-294 OSEL	Share	Soc
5	2701.12.01	1	Wechselspitze	MP-293	Bolt-on point	Pointe
5	2701.12.02	1	Wechselspitze	MP-293 L	Bolt-on point	Pointe
6	2700.41.13	2	Kegelschraube	M12x37 -12.9	Bolt	Vis
6	934D12M	2	Sechskantmutter	M12 ISO4032-12	Hex. nut	Ecrou 6 pans
7	2720.05.00	1	Pappscheibe	Ø4,5 mm	Washer	Rondelle



Corps de labour
Body

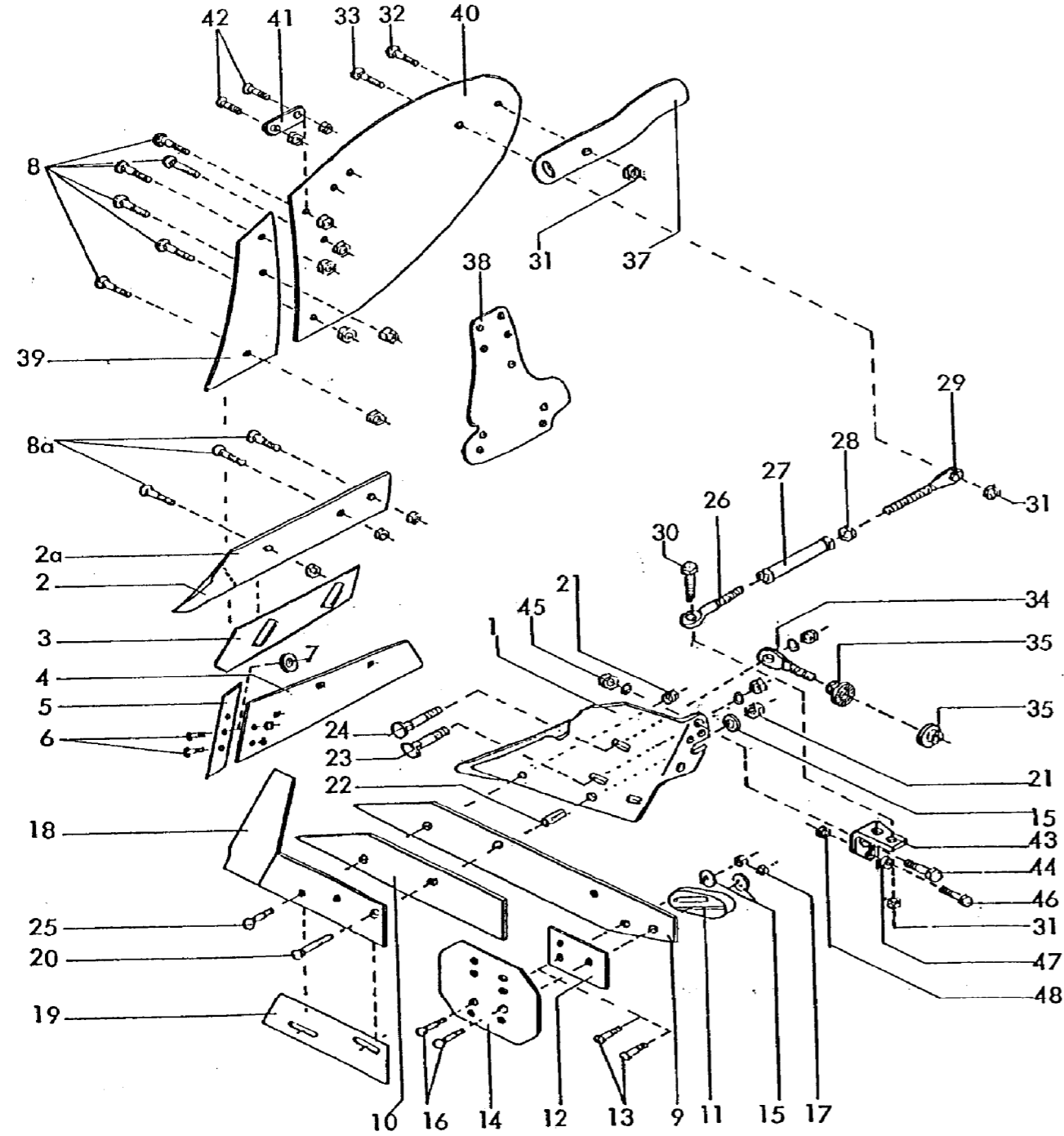

Bild Ref. Fig.	Bestellnr. Part-No. Référence	Stck. Qty. Qte.	Bezeichnung	Technische Angaben Technical data Données techniques	Description	Désignation
8	2700.26.03	6	Senkschraube	M12x30-10.9 4kt.	C sunk screw	Vis tête noyée
8,8a	934D12N	9	Sechskantmutter	M12 ISO4032-10	Hex. nut	Ecrou 6 pans
8a	2700.26.05	3	Senkschraube	M12x35-10.9 4kt.	C sunk screw	Vis tête noyée
9	2701.14.00	1	Anlage lang	WP-292 O	Long landside	Contresep long
10	2701.15.00	1	Anlage kurz	VP-292 O	Short landside	Contresep court
11	2700.30.01	1	Schleifsohle	UP-9	Heel	Talon
11	2700.30.02	1	Schleifsohle	UP-9 L	Heel	Talon
12	2708.15.00	1	Anlagenschoner	XP-4	Landside wearplate	Plaque latérale
13	2700.26.05	2	Senkschraube	M12x35-10.9 4kt.	C sunk screw	Vis tête noyée
14	2708.14.00	1	Anlagenschoner	XP-6	Landside wearplate	Plaque latérale
15	6436.60.03	2,3	Scheibe	C-13	Washer	Rondelle
16	2700.26.17	1	Senkschraube	M12x45-10.9 4kt.	C sunk screw	Vis tête noyée
16	2700.26.10	2	Senkschraube	M12x55-10.9 4kt.	C sunk screw	Vis tête noyée
17	934D12N	1,2	Sechskantmutter	M12 ISO4032-10	Hex. nut	Ecrou 6 pans
18	2722.05.01	1	Anlagensech	NG-71	Wing coulter	Coutre de contresep
18	2722.05.02	1	Anlagensech	NG-71 L	Wing coulter	Coutre de contresep
19	2701.21.00	1	Blechungunterlage	NG-71 (L)	Shim	Cale
20	2700.26.15	1	Senkschraube	M12x85-10.9	C sunk screw	Vis tête noyée
21	934D12N	2	Sechskantmutter	M12 ISO4032-10	Hex. nut	Ecrou 6 pans
22	1481D2145	1	Spannstift	21x45 DIN1481	Dowel Pin	Goupille serrage
22	1481D2150	1	Spannstift	21x50 DIN1481	Dowel Pin	Goupille serrage
22	1481D2155	1	Spannstift	21x55 DIN1481	Dowel Pin	Goupille serrage
22	1481D2160	1	Spannstift	21x60 DIN1481	Dowel Pin	Goupille serrage
23	2204.49.06	1	Sonderflachrundschr.	M16X70-8.8	Bolt	Vis
24	2204.49.09	1	Sonderflachrundschr.	M16X85-10.9	Bolt	Vis
24	127DB16A	2	Federring	B16 DIN127 vz.	Springwasher	Rondelle grower
24	934D16PA	2	Sechskantmutter	M16 ISO4032-8 verz.	Hex. nut	Ecrou 6 pans
25	933D1240N	1	Sechskantschraube	M12x40 ISO4017-10.9	Hex. bolt	Vis 6 pans
26-29	2700.19.01	1	SPANNSCHLOß		TURNBUCKLE CPL.	TIRANT CPL.
26	2700.17.02	1	Gewindeende li.		Eyebolt l.h.	Piton filete gauche
27	2700.20.00	1	Spannschloßmutter	L=190	Turnbuckle nut	Ecrou tendeur
28	934D20PA	1	Sechskantmutter	M20 ISO4032-8 vz.	Hex. nut	Ecrou 6 pans
29	2700.21.01	1	Gewindeende rechts	L=260	Eyebolt	Piton filete
30	931D1240N	1	Sechskantschraube	M12x40 DIN931-10.9	Hex. bolt	Vis 6 pans
31	980DV12N	1	Sicherungsmutter	VM12 DIN980-10	Lock nut	Ecrou frein
32	2700.26.05	1	Senkschraube	M12x35-10.9 4kt.	C sunk screw	Vis tête noyée
33	2700.26.09	1	Senkschraube	M12x50-10.9 4kt.	C sunk screw	Vis tête noyée
34,35	2720.09.02	1	KÖRPERSTELLSCHR.	M20, Bohrung Ø16	ADJUSTING SCREW	VIS DE REGLAGE



Corps de labour
Body

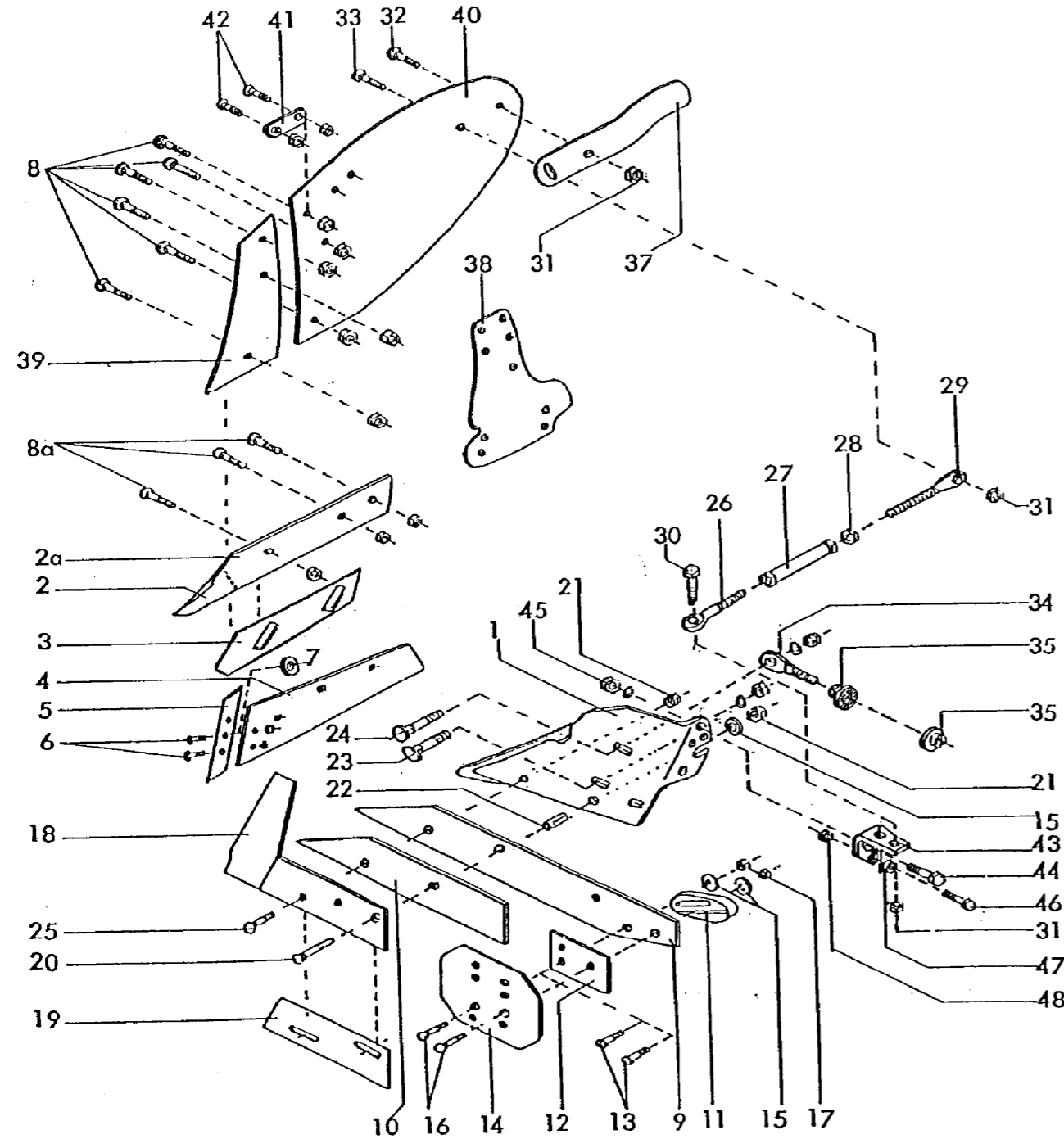

Bild Ref. Fig.	Bestellnr. Part-No. Référence	Stck. Qty. Qte.	Bezeichnung	Technische Angaben Technical data Données techniques	Description	Désignation
34	2720.07.01	1	Körperstellschraube	M20, Bohrung Ø16	Adjusting screw	Vis de réglage
35	934D20N	2	Sechskantmutter	M20-10	Hex. nut	Ecrou 6 pans
35	2720.11.01	2	Sperrkantscheibe	20 M	Washer	Rondelle
37	2701.19.01	1	Abstreifer	FP-78	Scraper	Décrottoir
37	2701.19.02	1	Abstreifer	FP-78 L	Scraper	Décrottoir
38	2701.09.00	2	Streichblechunterlage	URP-154	Shim	Cale
39	BP321/322P	1	Körper	BP-321, 322 P(L)	Body	Corps de labour
39	2701.07.01	1	Streichblech	VRP-292 O	Shin	Versoir
39	2701.07.02	1	Streichblech	VRP-292 O L	Shin	Versoir
40	2701.08.01	1	Streichblech	HRP-327 P	Shin	Versoir
40	2701.08.02	1	Streichblech	HRP-327 P L	Shin	Versoir
	BP350/351O		Körper	BP-350, 351 O(L)	Body	Corps de labour
39	2758.01.01	1	Streichblech	VRP-350 O	Shin	Versoir
39	2758.01.02	1	Streichblech	VRP-350 OL	Shin	Versoir
40	2758.02.01	1	Streichblech	HRP-350 O	Shin	Versoir
40	2758.02.02	1	Streichblech	HRP-350 OL	Shin	Versoir
41	2704.03.00	1	Verbindungsglasche		Latch	Plat
42	2700.26.01	2	Senkschraube	M12x25 -5.6 4kt.	C sunk screw	Vis tête noyée
42	934D12P	2	Sechskantmutter	M12 DIN 934-8	Hex. nut	Ecrou 6 pans
43	2720.06.05	1	Strebenhalter, rechts		Bracket	Support
43	2720.06.06	1	Strebenhalter, links		Bracket	Support
44	933D2045P	1	Sechskantschraube	M20x45 ISO4017-8.8	Hex. bolt	Vis 6 pans
45	934D20P	1	Sechskantmutter	M20 DIN934-8	Hex. nut	Ecrou 6 pans
45	127DB20A	1	Federring	B20 DIN127 vz.	Springwasher	Rondelle grower
46	933D1240N	1	Sechskantschraube	M12x40 ISO4017-10.9	Hex. bolt	Vis 6 pans
47	126D14	1	Scheibe	14 ISO7091	Washer	Rondelle
48	934D12N	1	Sechskantmutter	M12 ISO4032-10	Hex. nut	Ecrou 6 pans

Corps a versoirs claire-voie
Slatted body

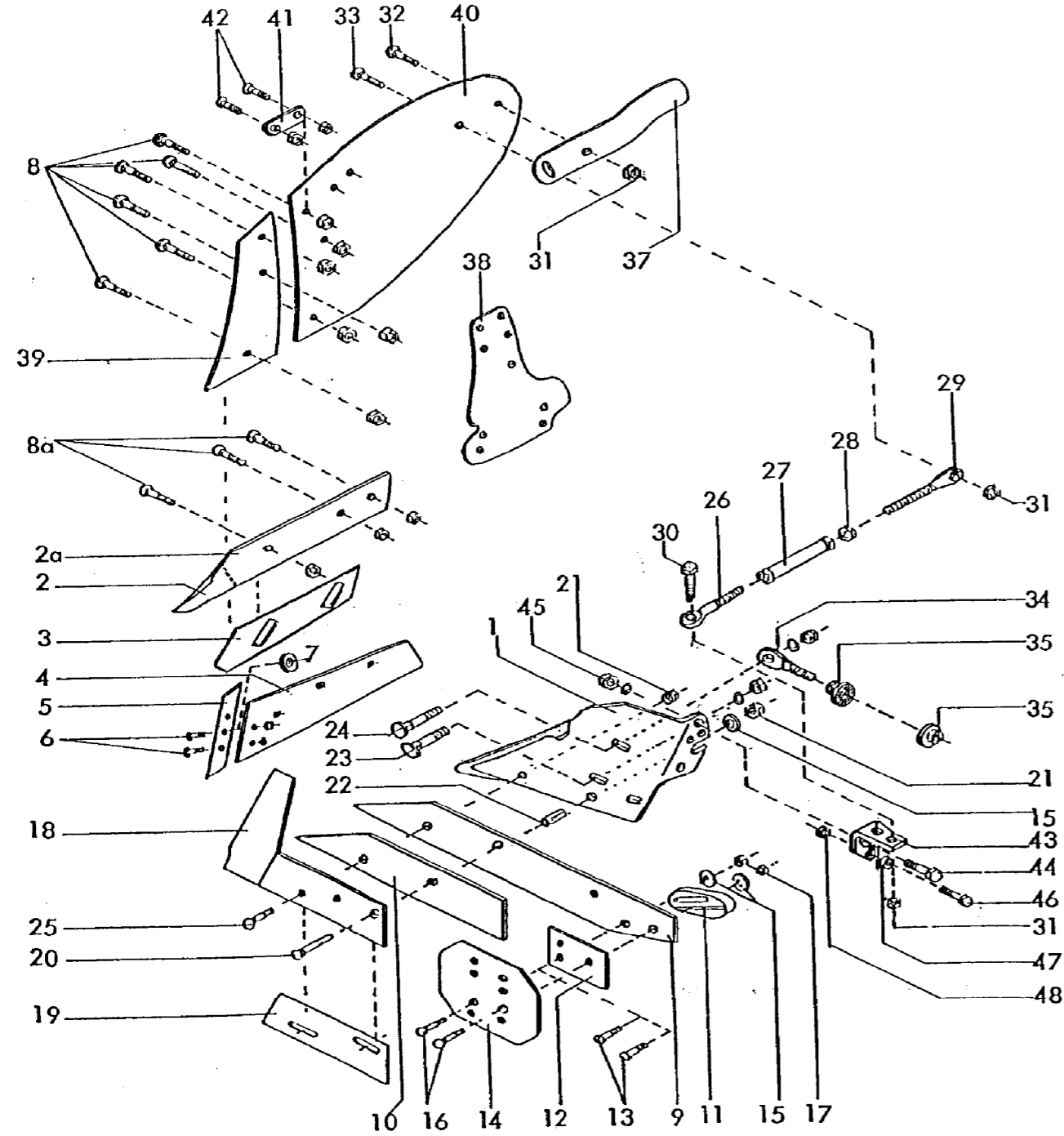

Bild Ref. Fig.	Bestellnr. Part-No. Référence	Stck. Qty. Qte.	Bezeichnung	Technische Angaben Technical data Données techniques	Description	Désignation
1	2759.01.01	1	Körperbrust	BP-330 W	Frog	Sep
1	2759.01.02	1	Körperbrust	BP-330 WL	Frog	Sep
1a	2751.02.05	1	Anlagenspitze	YP-350 W	Bolt-on point	Pointe
1b	2700.26.05	2	Senkschraube	M12x35-10.9 4kt.	C sunk screw	Vis tête noyée
1b	934D12M	2	Sechskantmutter	M12 ISO4032-12	Hex. nut	Ecrou 6 pans
2	2759.07.01	1	Streichblech	VRP-330 W	Shin	Versoir
2	2759.07.02	1	Streichblech	VRP-330 WL	Shin	Versoir
3	2759.10.01	1	Streichblechunterlage	T=2 mm	Shim	Cale
3a	2759.10.02	3	Streichblechunterlage	T=2 mm	Shim	Cale
3b	2759.10.03	1	Streichblechunterlage	T=2 mm	Shim	Cale
4	2700.26.03	2	Senkschraube	M12x30-10.9 4kt.	C sunk screw	Vis tête noyée
4	934D12PA	2	Sechskantmutter	M12 ISO4032-8 vz.	Hex. nut	Ecrou 6 pans
	BP330WS		Streifenkörper	BP-330 WS(L)	Slatted body	Corps à versoir claire-voie
5	2751.28.01	1	Plasma-Schar	SSP-350 WEP	Share	Soc
5	2751.28.02	1	Plasma-Schar	SSP-350 WELP	Share	Soc
5	2751.23.01	1	Schnabelschar	SSP-350 WE	Share	Soc
5	2751.23.02	1	Schnabelschar	SSP-350 WEL	Share	Soc
6	2751.22.01	1	Schar für Wechselsp.	SSP-350 WSE	Share	Soc
6	2751.22.02	1	Schar für Wechselsp.	SSP-350 WSEL	Share	Soc
7	2751.09.01	1	Wechselspitze	MP-350	Bolt-on point	Pointe
7	2751.09.02	1	Wechselspitze	MP-350 L	Bolt-on point	Pointe
	BP331WS		Streifenkörper	BP-331 WS(L)	Slatted body	Corps à versoir claire-voie
5	2751.30.01	1	Plasma-Schar	SSP-351 WEP	Share	Soc
5	2751.30.02	1	Plasma-Schar	SSP-351 WELP	Share	Soc
8	2700.26.03	4	Senkschraube	M12x30-10.9 4kt.	C sunk screw	Vis tête noyée
8a	2700.41.13	2	Kegelschraube	M12x37 -12.9	Bolt	Vis
8a	934D12M	6	Sechskantmutter	M12 ISO4032-12	Hex. nut	Ecrou 6 pans
9	2751.03.05	1	Anlage lang	WP-351 W	Long landside	Contresep long
10	2751.03.06	1	Anlage kurz	VP-351 W	Short landside	Contresep court
11	2700.30.01	1	Schleifsohle	UP-9	Heel	Talon
11	2700.30.02	1	Schleifsohle	UP-9 L	Heel	Talon
12	2708.15.00	1	Anlagenschoner	XP-4	Landside wearplate	Plaque latérale
13	2700.41.13	2	Kegelschraube	M12x37 -12.9	Bolt	Vis
14	2708.14.00	1	Anlagenschoner	XP-6	Landside wearplate	Plaque latérale
14	2708.14.01	1	Anlagenschoner	XP-61	Landside wearplate	Plaque latérale
15	6436.60.03	2,3	Scheibe	C-13	Washer	Rondelle
16	2700.26.17	1	Senkschraube	M12x45-10.9 4kt.	C sunk screw	Vis tête noyée
16	2700.26.10	2	Senkschraube	M12x55-10.9 4kt.	C sunk screw	Vis tête noyée

Corps a versoirs claire-voie
Slatted body

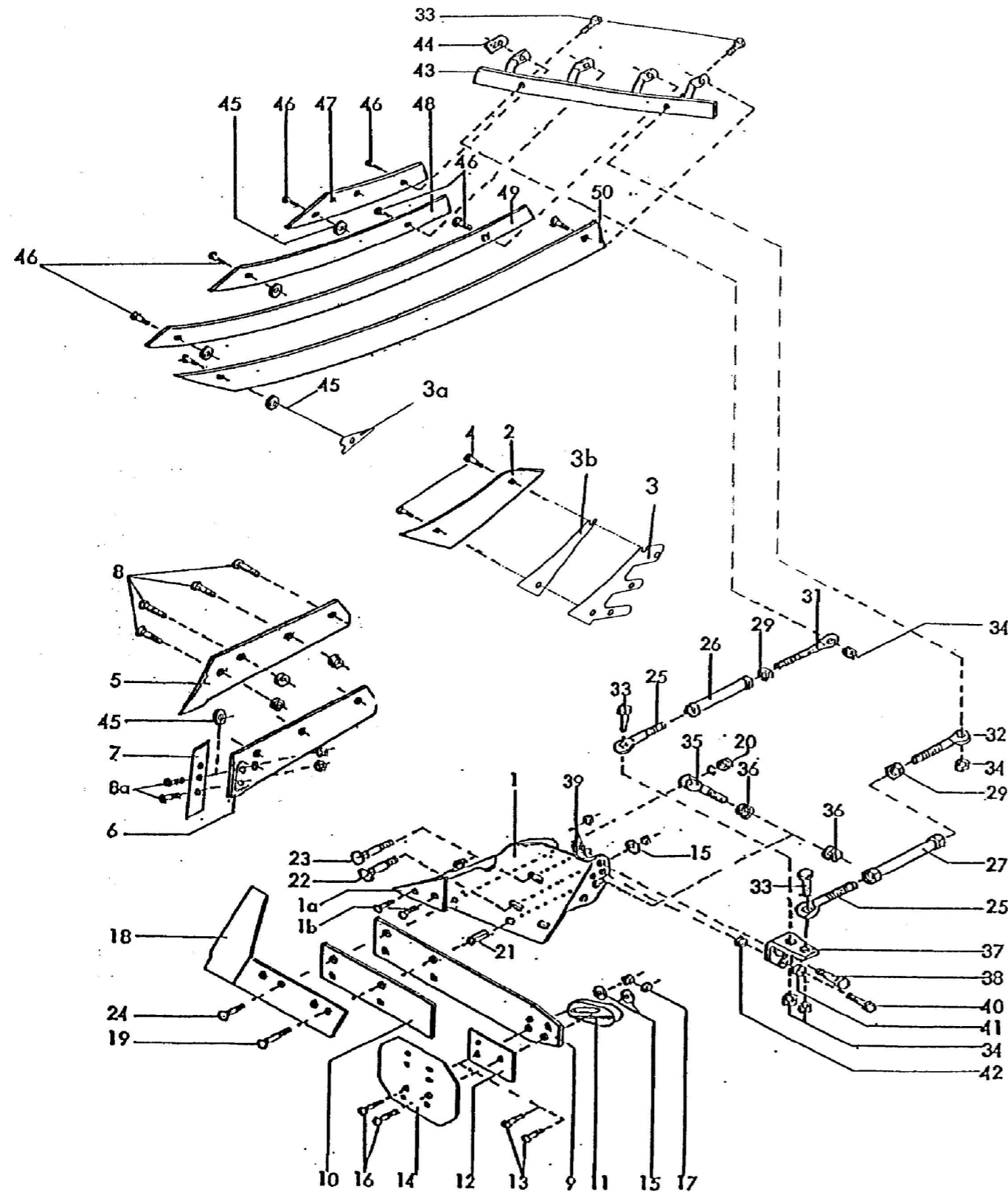

Bild Ref. Fig.	Bestellnr. Part-No. Référence	Stck. Qty. Qte.	Bezeichnung	Technische Angaben Technical data Données techniques	Description	Désignation
17	934D12N	1,2	Sechskantmutter	M12 ISO4032-10	Hex. nut	Ecrou 6 pans
18	2751.10.01	1	Anlagensech	NG-35	Wing coulter	Coutre de contresep
18	2751.10.02	1	Anlagensech	NG-35 L	Wing coulter	Coutre de contresep
19	2700.26.15	1	Senkschraube	M12x85-10.9	C sunk screw	Vis tête noyee
20	934D12N	2	Sechskantmutter	M12 ISO4032-10	Hex. nut	Ecrou 6 pans
21	1481D2145	1	Spannstift	21x45 DIN1481	Dowel Pin	Goupille serrage
21	1481D2150	1	Spannstift	21x50 DIN1481	Dowel Pin	Goupille serrage
21	1481D2155	1	Spannstift	21x55 DIN1481	Dowel Pin	Goupille serrage
21	1481D2160	1	Spannstift	21x60 DIN1481	Dowel Pin	Goupille serrage
22	2204.49.08	1	Sonderflachrundschr.	M16X75-10.9	Bolt	Vis
23	2204.49.09	1	Sonderflachrundschr.	M16X85-10.9	Bolt	Vis
23	127DB16A	2	Federring	B16 DIN127 vz.	Springwasher	Rondelle grower
23	934D16PA	2	Sechskantmutter	M16 ISO4032-8 verz.	Hex. nut	Ecrou 6 pans
24	2700.26.05	1	Senkschraube	M12x35-10.9 4kt.	C sunk screw	Vis tête noyee
25-31	2708.26.00	1	SPANNSCHLOß		TURNBUCKLE CPL.	TIRANT CPL.
25	2700.17.02	1	Gewindeende li.		Eyebolt l.h.	Piton filete gauche
26	2708.25.00	1	Spannschloßmutter	L=140 mm	Turnbuckle nut	Ecrou tendeur
29	934D20PA	1	Sechskantmutter	M20 ISO4032-8 vz.	Hex. nut	Ecrou 6 pans
31	2700.17.01	1	Gewindeende rechts		Eyebolt	Piton filete
25-32	2700.19.02	1	SPANNSCHLOß		TURNBUCKLE CPL.	TIRANT CPL.
25	2700.17.02	1	Gewindeende li.		Eyebolt l.h.	Piton filete gauche
27	2700.20.00	1	Spannschloßmutter	L=190	Turnbuckle nut	Ecrou tendeur
29	934D20PA	1	Sechskantmutter	M20 ISO4032-8 vz.	Hex. nut	Ecrou 6 pans
32	2700.21.02	1	Gewindeende rechts	L=300	Eyebolt	Piton filete
33	931D1240N	4	Sechskantschraube	M12x40 DIN931-10.9	Hex. bolt	Vis 6 pans
34	980DV12N	4	Sicherungsmutter	VM12 DIN980-10	Lock nut	Ecrou frein
35,36	2720.09.02	1	KÖRPERSTELLSCHR.	M20, Bohrung Ø16	ADJUSTING SCREW	VIS DE REGLAGE
35	2720.07.01	1	Körperstellschraube	M20, Bohrung Ø16	Adjusting screw	Vis de réglage
36	934D20N	2	Sechskantmutter	M20 ISO4032-10	Hex. nut	Ecrou 6 pans
36	2720.11.01	2	Sperrkantscheibe	20 M	Washer	Rondelle
37	2720.06.05	1	Strebenhalter, rechts		Bracket	Support
37	2720.06.06	1	Strebenhalter, links		Bracket	Support
38	933D2045P	1	Sechskantschraube	M20x45 ISO4017-8.8	Hex. bolt	Vis 6 pans
39	934D20P	1	Sechskantmutter	M20 DIN934-8	Hex. nut	Ecrou 6 pans
39	127DB20A	1	Federring	B20 DIN127 vz.	Springwasher	Rondelle grower
40	933D1235P	1	Sechskantschraube	M12x35 ISO4017-8.8	Hex. bolt	Vis 6 pans
41	126D14	1	Scheibe	14 ISO7091	Washer	Rondelle
42	934D12PA	1	Sechskantmutter	M12 ISO4032-8 vz.	Hex. nut	Ecrou 6 pans

Corps a versoirs claire-voie
Slatted body



Bild Ref. Fig.	Bestellnr. Part-No. Référence	Stck. Qty. Qte.	Bezeichnung	Technische Angaben Technical data Données techniques	Description	Désignation
43	2759.08.01	1	Abstützung, li.		Strut	Support
43	2759.08.02	1	Abstützung, re.		Strut	Support
44	2731.07.00	4	Pappscheibe	T=2,5 mm	Washer	Rondelle
45	2720.05.00	5	Pappscheibe	Ø4,5 mm	Washer	Rondelle
46	2700.41.13	8	Kegelschraube	M12x37 -12.9	Bolt	Vis
46	980DV12M	8	Sicherungsmutter	VM12 ISO7042-12	Lock nut	Ecrou frein
47	2759.03.01	1	Streifen	SRP-330 W 1	Slat	Lame de versoir
47	2759.03.02	1	Streifen	SRP-330 WL 1	Slat	Lame de versoir
48	2759.04.01	1	Streifen	SRP-330 W 2	Slat	Lame de versoir
48	2759.04.02	1	Streifen	SRP-330 WL 2	Slat	Lame de versoir
49	2759.05.01	1	Streifen	SRP-330 W 3	Slat	Lame de versoir
49	2759.05.02	1	Streifen	SRP-330 WL 3	Slat	Lame de versoir
50	2759.06.01	1	Streifen	SRP-330 W 4	Slat	Lame de versoir
50	2759.06.02	1	Streifen	SRP-330 WL 4	Slat	Lame de versoir

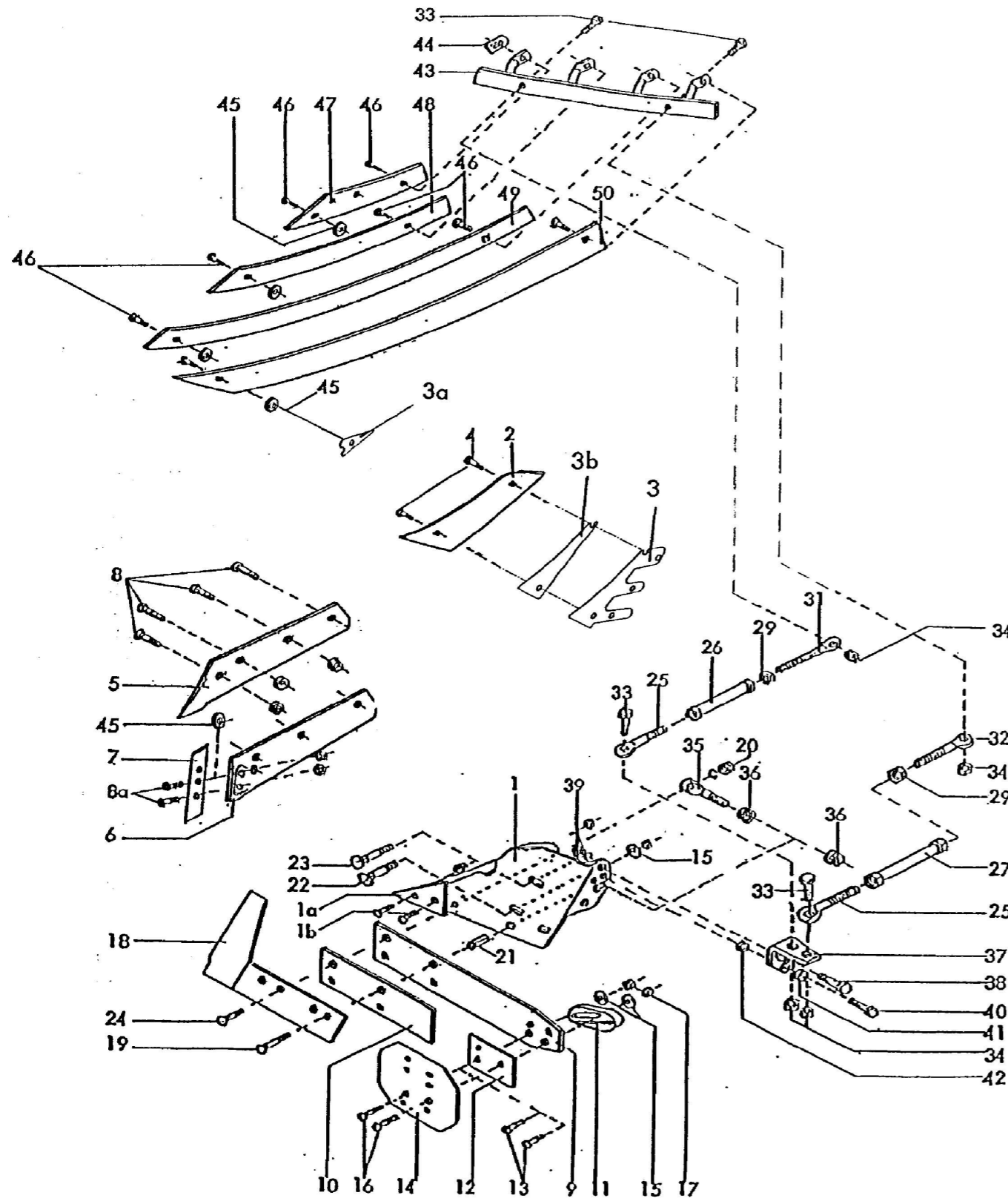

Défecteur DG-52 R
Trashboard DG-52 R

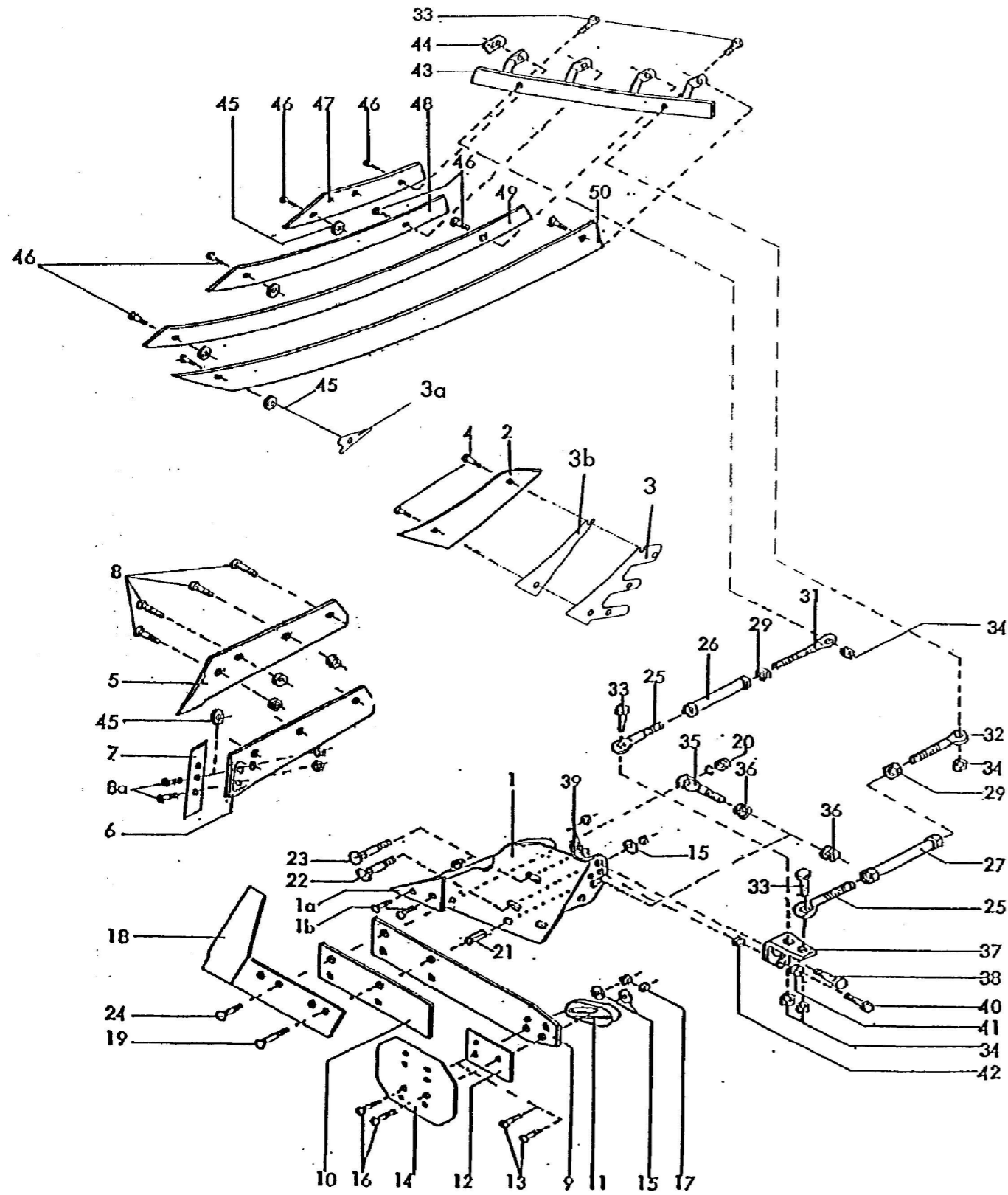
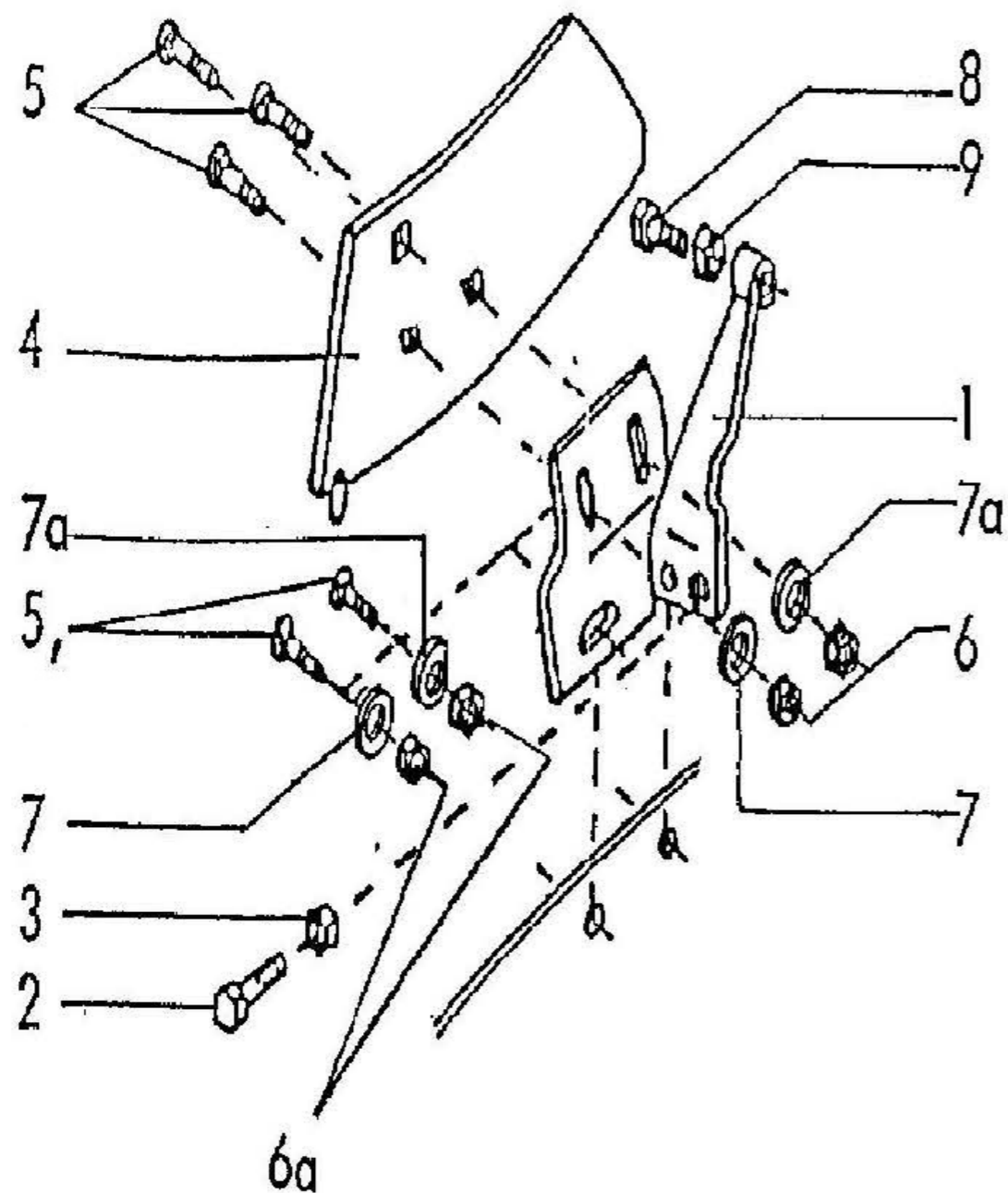

Repere	Quantite	Reference	Designation
1	1	2729.07.01	Plaque de réglage EBP-4 Adjust.plate EBP-4
2	1	933D1660PA	Vis Hex. M16x60 Din 933-8.8 Hex.bolt M16x60 Din 933-8.8
3	1	936D16PA	Ecrou Hex. M16 Din936-8 Hex.nut M16 Din936-8
4	1	2729.08.01	Versoir PDG-52 Shin PDG-52
5	5	2700.26.05	Vis tête noyée M12x35-10.9 C sunk screw M12x35-10.9
6	3	934D12M	Ecrou Hex. M12 Hex.nut M12
6a	2	980DV12M	Ecrou frein VM 12 Lock nut VM 12
7	3	6436.60.03	Rondelle C-13 Washer C-13
7a	2	6437.00.01	Rondelle C-132 Washer C-132
8	1	933D1050PA	Vis Hex. M10x50-8.8 Z Hex.bolt M10x50-8.8 Z
9	1	934D10PA	Ecrou Hex M10 Din 934-8 Hex.nut M10 Din 934-8
	2	2731.07.00	Rondelle de carton 2,5 épais Washer 2,5 Dick
	2	2720.05.00	Rondelle de carton D45 Washer D45

Défecteur DG-52 L
Trashboard DG-52 L

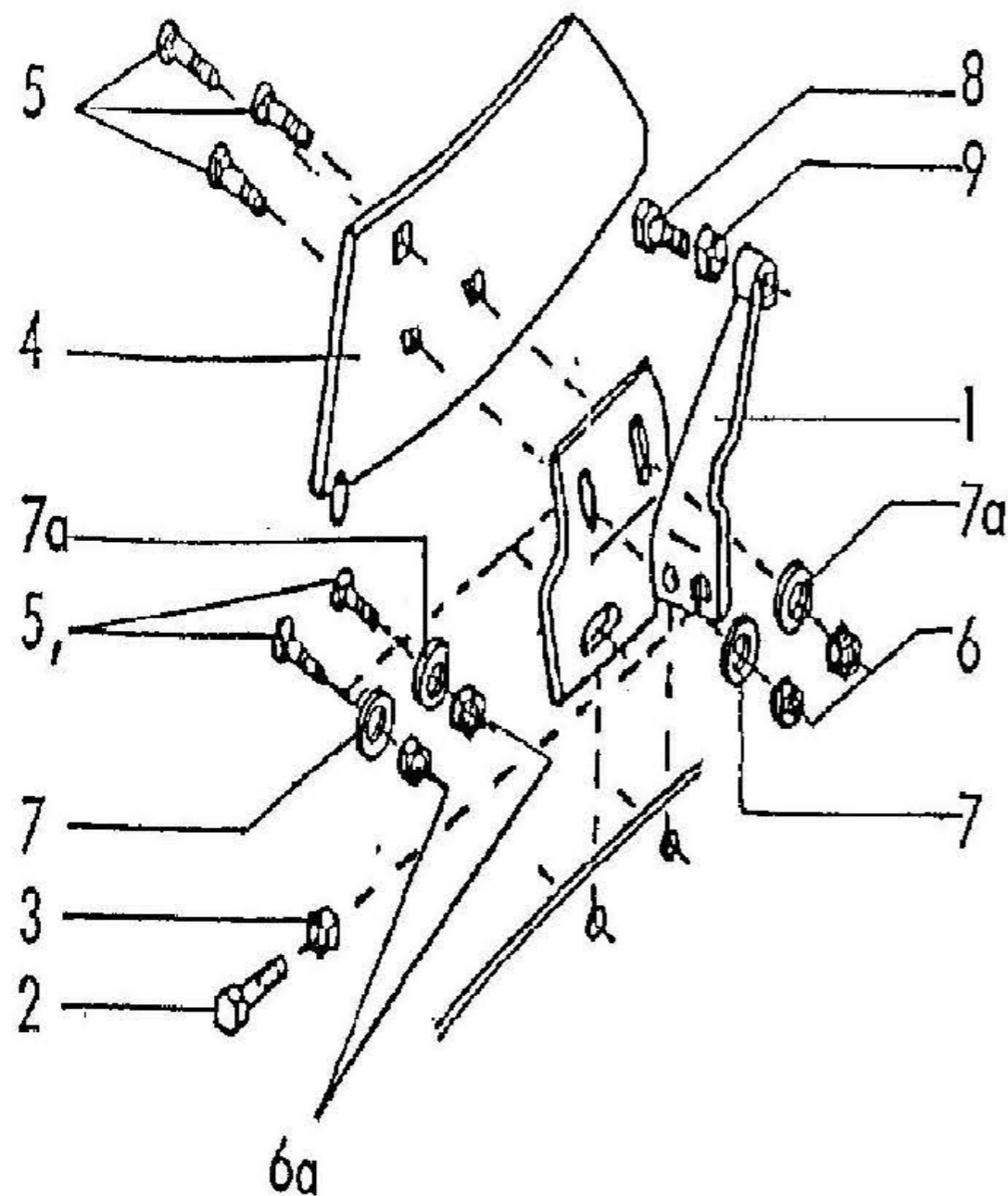

Repere	Quantite	Reference	Designation
1	1	2729.07.02	Plaque de réglage EBP-4 L Adjust.plate EBP-4 L
2	1	933D1660PA	Vis Hex. M16x60 Din 933-8.8 Hex.bolt M16x60 Din 933-8.8
3	1	936D16PA	Ecrou Hex. M16 Din936-8 Hex.nut M16 Din936-8
4	1	2729.08.02	Versoir PDG-52 L Shin PDG-52 L
5	5	2700.26.05	Vis tête noyée M12x35-10.9 C sunk screw M12x35-10.9
6	3	934D12M	Ecrou Hex. M12 Din 934-12 Hex.nut M12 Din 934-12
6a	2	980DV12M	Ecrou frein VM 12 Lock nut VM 12
7	3	6436.60.03	Rondelle C-13 Washer C-13
7a	2	6437.00.01	Rondelle C-132 Washer C-132
8	1	933D1050PA	Vis Hex. M10x50-8.8 Z Hex.Bolt M10x50-8.8 verz.
9	1	934D10PA	Ecrou Hex M10 Din 934-8 Hex.nut M10 Din 934-8
	2	2731.07.00	Rondelle de carton 2,5 épais Washer 2,5 Dick
	2	2720.05.00	Rondelle de carton D45 Washer D45

Défecteur DG-51 UR
Trashboard DG-51 UR

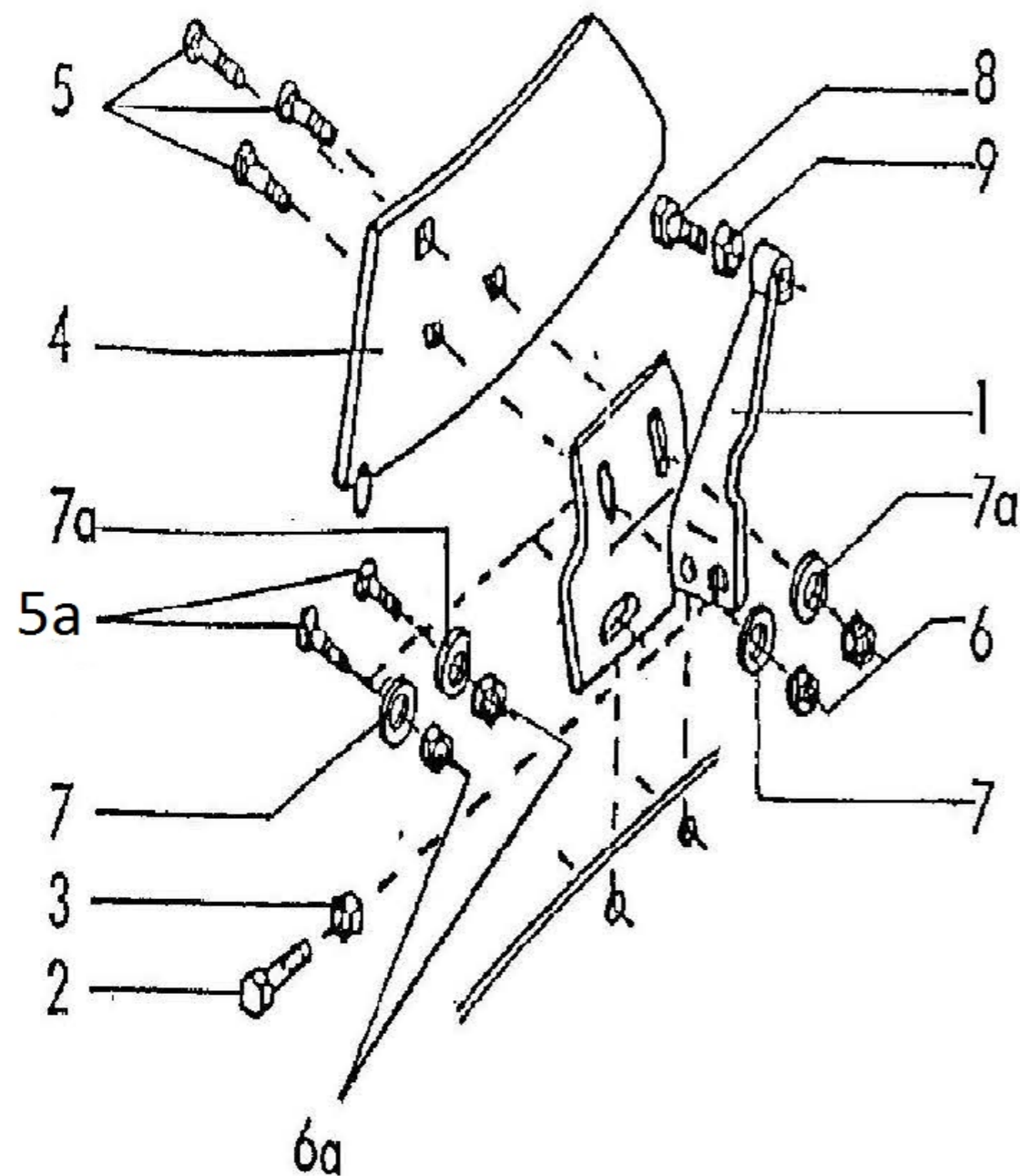

Repere	Quantite	Reference	Designation
1	1	2729.07.01	Plaque de réglage EBP-4 Adjust.plate EBP-4
2	1	933D1660PA	Vis Hex. M16x60 Din 933-8.8 Hex.bolt M16x60 Din 933-8.8
3	1	936D16PA	Ecrou Hex. M16 Din936-8 Hex.nut M16 Din936-8
4	1	2729.01.01	Versoir PDG-51 U Shin PDG-51 U
5	3	2700.26.05	Vis tête noyée M12x35-10.9 C sunk screw M12x35-10.9
5a	2	2700.41.14	Vis M12x40-12.9 Bolt M12x40-12.9
6	3	934D12M	Ecrou Hex. M 12 Hex.nut M 12
7	3	6436.60.03	Rondelle C-13 Washer C-13
7a	2	6437.00.01	Rondelle C-132 Washer C-132
8	1	933D1050PA	Vis Hex. M10x50-8.8 Z Hex.Bolt M10x50-8.8 verz.
9	1	934D10PA	Ecrou Hex M10 Din 934-8 Hex.nut M10 Din 934-8
	2	2731.07.00	Rondelle de carton 2,5 épais Washer 2,5 Dick
	2	2720.05.00	Rondelle de carton D45 Washer D45
6a	2	980DV12M	Ecrou frein VM 12 Lock nut VM 12

Défecteur DG-51 UL
Trashboard DG-51 UL

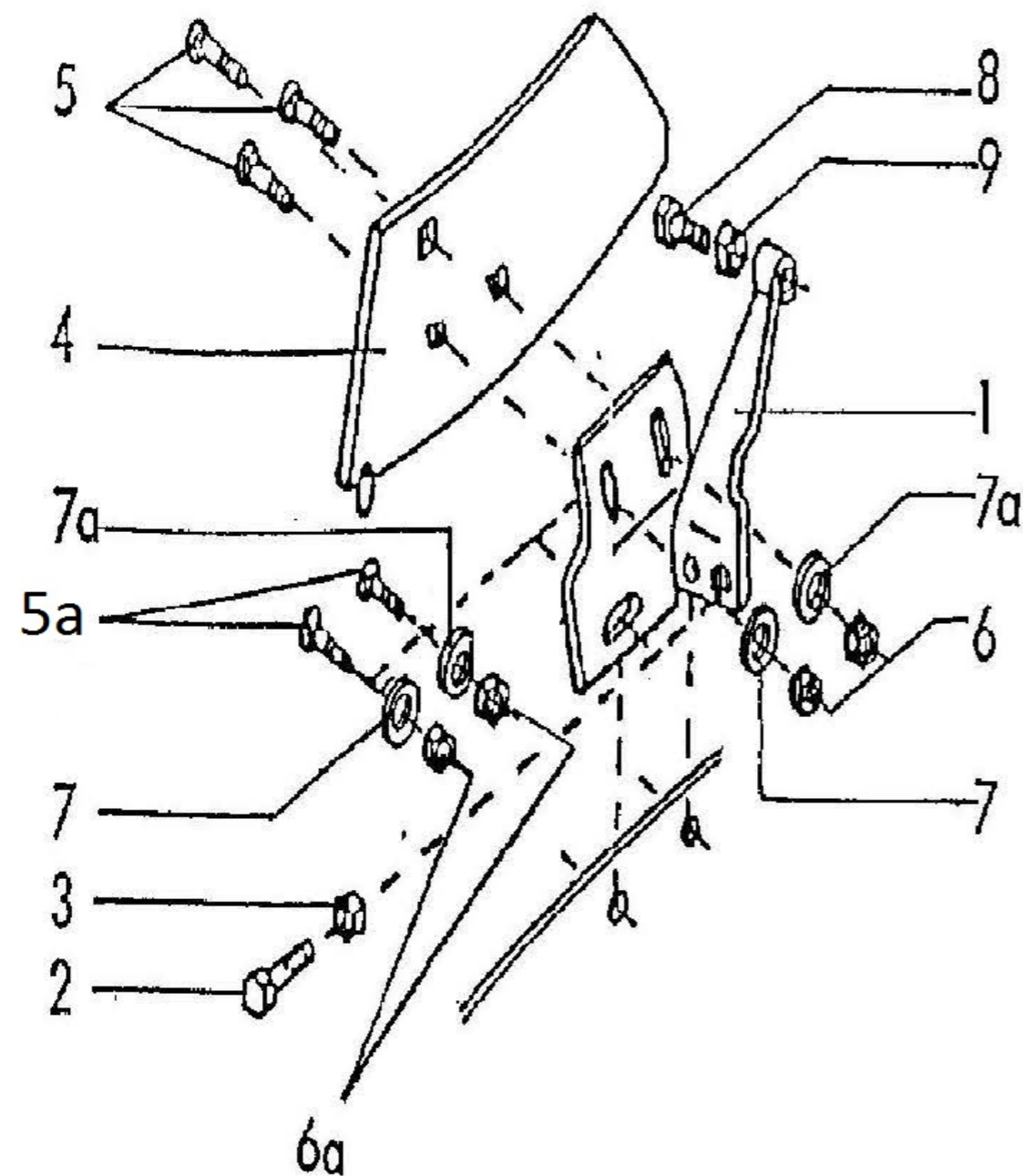

Repere	Quantite	Reference	Designation
1	1	2729.07.02	Plaque de réglage EBP-4 L Adjust.plate EBP-4 L
2	1	933D1660PA	Vis Hex. M16x60 Din 933-8.8 Hex.bolt M16x60 Din 933-8.8
3	1	936D16PA	Ecrou Hex. M16 Din936-8 Hex. nut M16 Din936-8
4	1	2729.01.02	Versoir PDG-51 U L Shin PDG-51 U L
5	3	2700.26.05	Vis tête noyée M12x35-10.9 C sunk screw M12x40-10.9
5a	2	2700.41.14	Vis M12x40-12.9 Bolt M12x40-12.9
6	3	934D12M	Ecrou Hex. M 12 Hex.nut M12
7	3	6436.60.03	Rondelle C-13 Washer C-13
7a	2	6437.00.01	Rondelle C-132 Washer C-132
8	1	933D1050PA	Vis Hex. M10x50-8.8 Z Hex.Bolt M10x50-8.8 Z.
9	1	934D10PA	Ecrou Hex M10 Din 934-8 Hex.nut M10 Din 934-8
	2	2731.07.00	Rondelle de carton 2,5 épais Washer 2,5 Dick
	2	2720.05.00	Rondelle de carton D45 Washer D45
6a	2	980DV12M	Ecrou frein VM 12 Lock nut VM 12



Rasette Vari-Fix 200 B cpl.
Skimmer Varifix 200 B cpl.

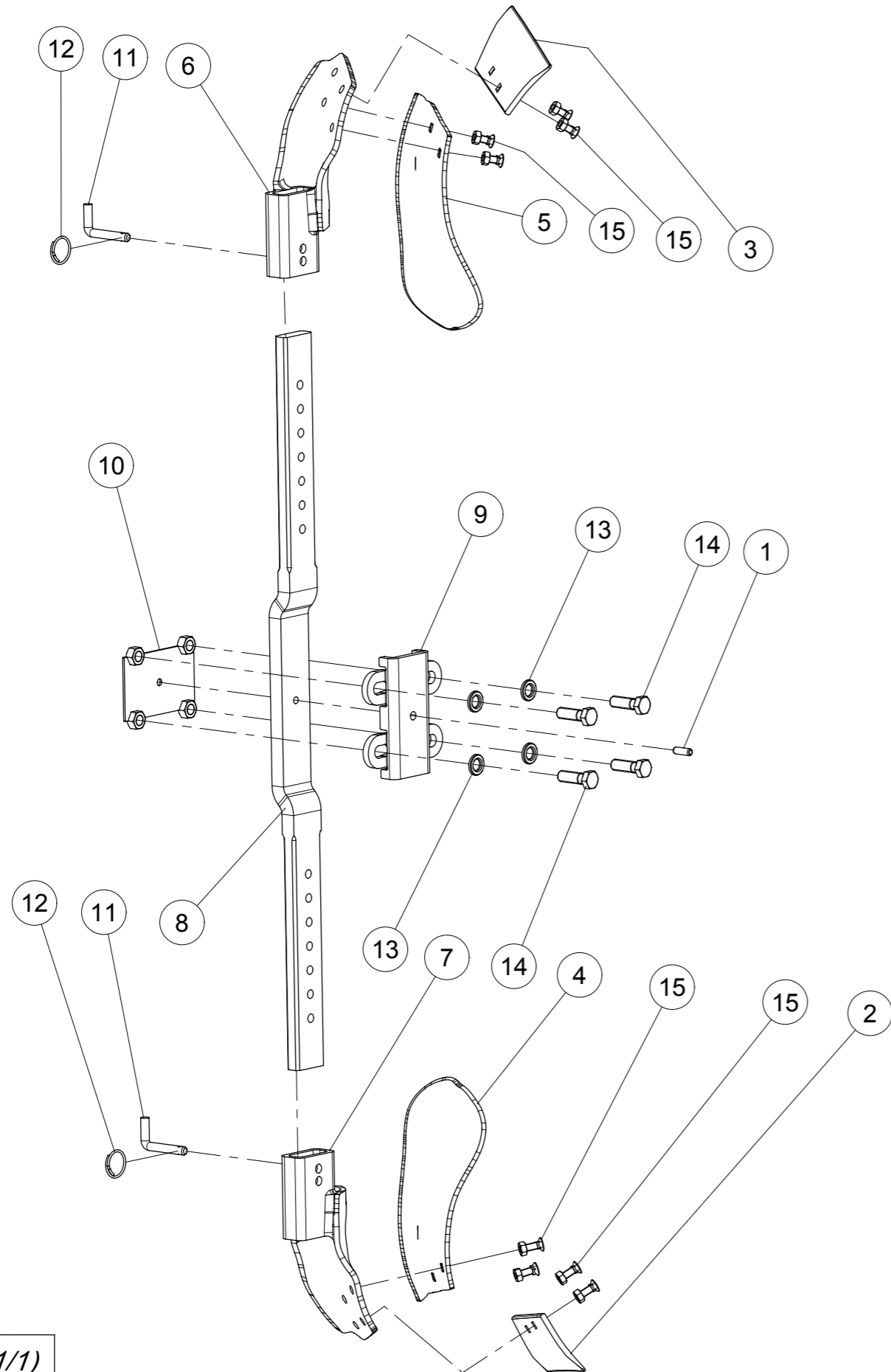

Index	Quantite	Reference	Designation
1	1	1481D1030A	Goupille elastique 10 X 30 ISO8752 Z Spring Pin 10 X 30 ISO8752 Z
2	1	2715.05.01	Soc de rasette, Drt Skimmer share R.H.
3	1	2715.05.02	Soc de rasette, Gche Skimmer share L.H
4	1	2715.07.01	Versoir de rasette, Drt Skimmer shin R.H.
5	1	2715.07.02	Versoir de rasette, Gche Skimmer shin L.H.
6	1	2754.29.01	Pied soudé droit Vari Fix Vari-Fix Frog R.H.
7	1	2754.29.02	Pied soudé gauche Vari Fix Vari-Fix Frog L.H.
8	1	2754.30.01	Montant de rasette Stalk RH 75/80
9	1	2754.32.02	Plaque d'assemblage mounting plate
10	1	2754.39.01	Plat de serrage Lock plate
11	2	6241.29.02	Axe TB-12x50 Pin TB-12x50
12	2	6608.12.07	Circlip Circlip
13	4	6916D17A	Rondelle 17 EN14399-6 Z Washer 17 EN14399-6 Z
14	4	960D161550NA	Vis hex. M16x1.5x50 ZNBL Hex. Screw M16x1.5x50 ZNBL
15	8	VI 13 14	Vis tête noyee 608-8.8 ZNBL M10x25+MU C sunk screw M10X25 DIN608-8.8 + Hex. nut ZNBL



Console avec roue
Console with Wheel

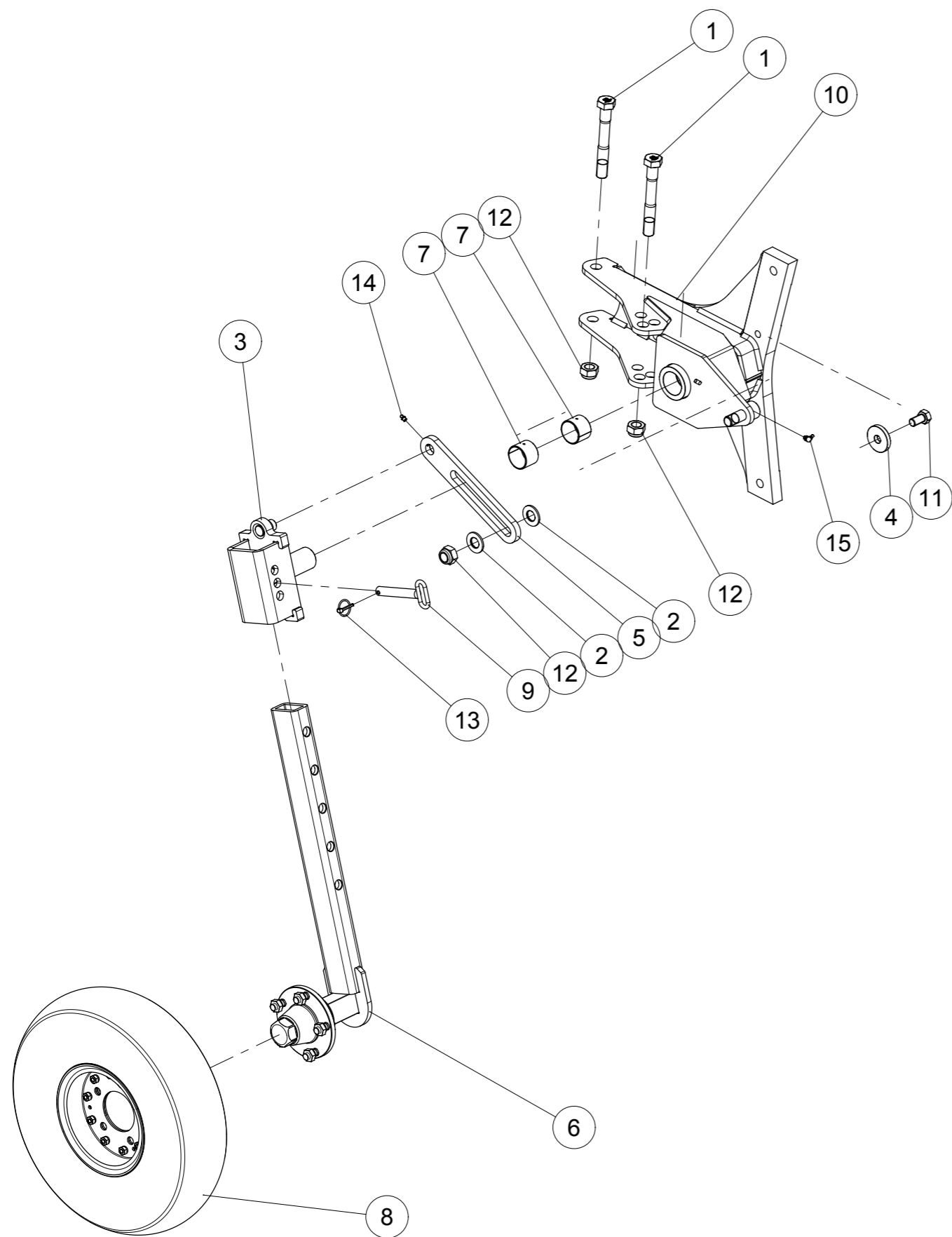

Index	Quantite	Reference	Designation
1	2	1 118 356	Vis H M24x180 - 10.9 ZNBL, filet /36 mm Screw H M24x180 - 10.9 ZNBL, thread /36 mm
2	2	1 123 406	Rondelle Ertalon Dia 24x48 ep4 Washer Ertalon Dia. 24x48 thick. 4
3	1	1 123 410	Support age - roue Wheel bracket
4	1	1 123 411	Rondelle de roue Wheel washer
5	1	1 123 412	Glissiere - butee Roue Slide (wheel depth adjustment)
6	1	1 123 413	Montant de roue Ar. Rear wheel arm
7	2	122 246	Bague bronze - Dia50x55, lg. : 40 mm Bronze bushing - Dia50x55, lg. : 40 mm
8	1	198 710	Roue complete - 600 x 9, 5 trous Complete wheel - 600 x 9
9	1	198 808	Broche de réglage Adjusting pin for wheel
10	1	4814.00.24	Console avec support de roue Console with Wheel support
11	1	VI 44 02	Vis H M18x 35 - 8.8 ZNBL Screw H M18x 35 - 8.8 ZNBL
12	3	VJ 331	Ecrou frein std H M 24 - 8 ZNBL Nyloc nut std H M 24 - 8 ZNBL
13	1	VL 101	Goupille "Clips" Dia6 Z Lynch pin "Clips" Dia6 Z
14	1	VM 201	Graisneur droit - M8, pas125 Grease nipple - M8, thread125
15	1	VM 203	Graisneur coude 90° M8x125 Grease nipple 90° M8x125

4814.00.23 (1/1)



RABE

ZI Nord Les Gaudères
37130 Langeais

France - Frankreich

Tel. (+33) 2 47 96 72 61
Fax (+33) 2 47 96 71 85
info@rabe-gb.fr
www.rabe-gb.fr

RABE

Am Rabewerk 1
49152 Bad Essen

Allemagne - Deutschland

Tel. +49 (0) 54 72 771 - 0
Fax +49 (0) 54 72 771 -195
info@rabe-gb.de
www.rabe-gb.de