

--	--	--	--	--	--	--	--

		/					
--	--	---	--	--	--	--	--



Important pour la commande de pièces de rechange

Lors de chaque commande de pièces, veuillez nous communiquer les données suivantes:

1. Type de la machine (gravé sur la plaque d'identification).
2. Numéro de série de la machine (gravé sur la Plaque d'identification et le bâti).
3. Numéro de pièce.
4. La quantité nécessaire de pièces de rechange.

Wichtig bei Ersatzteilbestellungen

Bitte machen Sie bei jeder Bestellung folgende Angaben:

1. Maschinentype (auf Typenschild eingeschlagen).
2. Maschinenummer (auf Typenschild und Rahmen eingeschlagen).
3. Bestellnummer
4. Die gewünschte Stückzahl der Ersatzteile.

Plaquette / Typenschild



Sommaire

Avant-Train fixe D2D3 L2.....	7
Valve Push-Pull M18x15 a clapet	9
Caisson charrue	10
Securité boulon console.....	11
Tendille 70x30 RH80 cpl.	12
Vis de fixation cpl. T30 D16/20	13
Kit de visserie pour tendille(épaisse 30) cpl.....	14
Corps de labour	15
Corps a versoirs claire-voie.....	18
Défecteur DG-52 R.....	21
Défecteur DG-52 L	22
Défecteur DG-51 UR	23
Défecteur DG-51 UL.....	24
Rasette Vari-Fix 200 B cpl.	25
Console avec roue	26

Inhaltsverzeichnis

Pflugturm D2D3 L2.....	7
Hydraulikstecker M18x15 a.....	9
Pflug Rahmen.....	10
Konsole kpl.....	11
Bogengrindel 70x30 RH80 kpl.	12
Befestigungsschrauben kpl. T30 D16/20-Teilesatz	13
Grindelbefestigungsteile (30 Dick)-Teilesatz	14
Vollkörper BP 322 P	15
Streifenkörper BP 331 WS	18
Einlegestreichblech DG-52 R.....	21
Einlegestreichblech DG-52 L	22
Einlegestreichblech DG-51 UR	23
Einlegestreichblech DG-51 UL.....	24
Vorschäler-Vari-Fix 200 B kpl.	25
Konsole mit Radhalter + Rad	26



Avant - Train fixe D2D3 L2
Pflugturm D2D3 L2

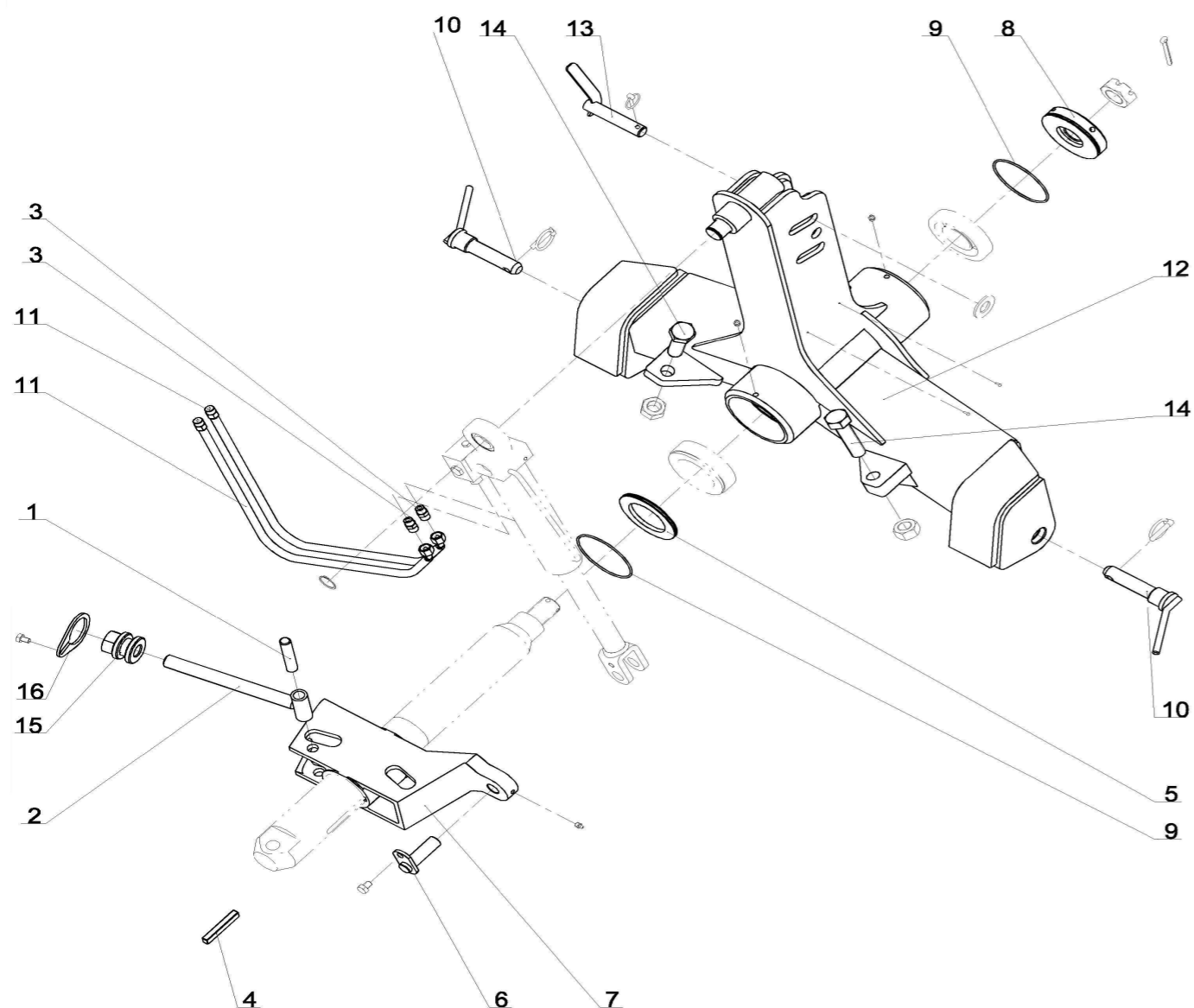

Repere	Quantite	Reference	Designation
1	1	1 112 410	Axe de vis de reglage lateral Bolzen (Seiteneinstellungsschraube)
2	1	1 112 719	Vis reglage lateral RH80 Schraube (Seiteneinstellung) RH80
3	2	1 116 363	Union nu male12 + male3/8 Cyl Verschraubung M12 + M3/8 Cyl
4	1	1 122 001	Clavette de fusee RH90-RH110 Keil (Drehachse) RH90-RH110
5	1	1 122 019	Rondelle butee RH90 Anschlagsscheibe RH90
6	1	1 122 307	Axe inferieur verin Untere achse (zylinder)
7	1	1 122 308 U	Porte fusee RH90 Drehachse RH90
8	1	1 122 318	Ecrou de fusee RH90 Mutter fur Drehachse RH90
9	2	1 122 372	Joint torique 120x3,5 / D:130 O-Ring 120x3,5 / D:130
10	2	1 122 717	Broche d'attelage fixe N°2 Kupplungsbolzen Nr2 fest
11	2	1 123 113	Flex. Hyd. - Dia 5/16", Lg.:1500mm, E12 a 45°-MVA18 Schlauch - 5/16", Lg.:1500mm, E12 45°- MVA18
12	1	1 123 401	Avant train Pflugturm
13	1	1 123 402	Broche 3em Point Avt-Train Oberlenkerbolzen (Pflugturm)
14	2	1 123 405	Vis H M27x100 8.8 Z Filt. total Neigungsschraube H M27x100 8.8 Z
15	1	1 123 414	Guide de reglage deport Führung (Vorderfurcheneinstellung)
16	1	1 123 415	Rondelle de guidage deport Führungsscheibe (Vorderfurcheneinstellung)



Avant - Train fixe D2D3 L2
Pflugturm D2D3 L2

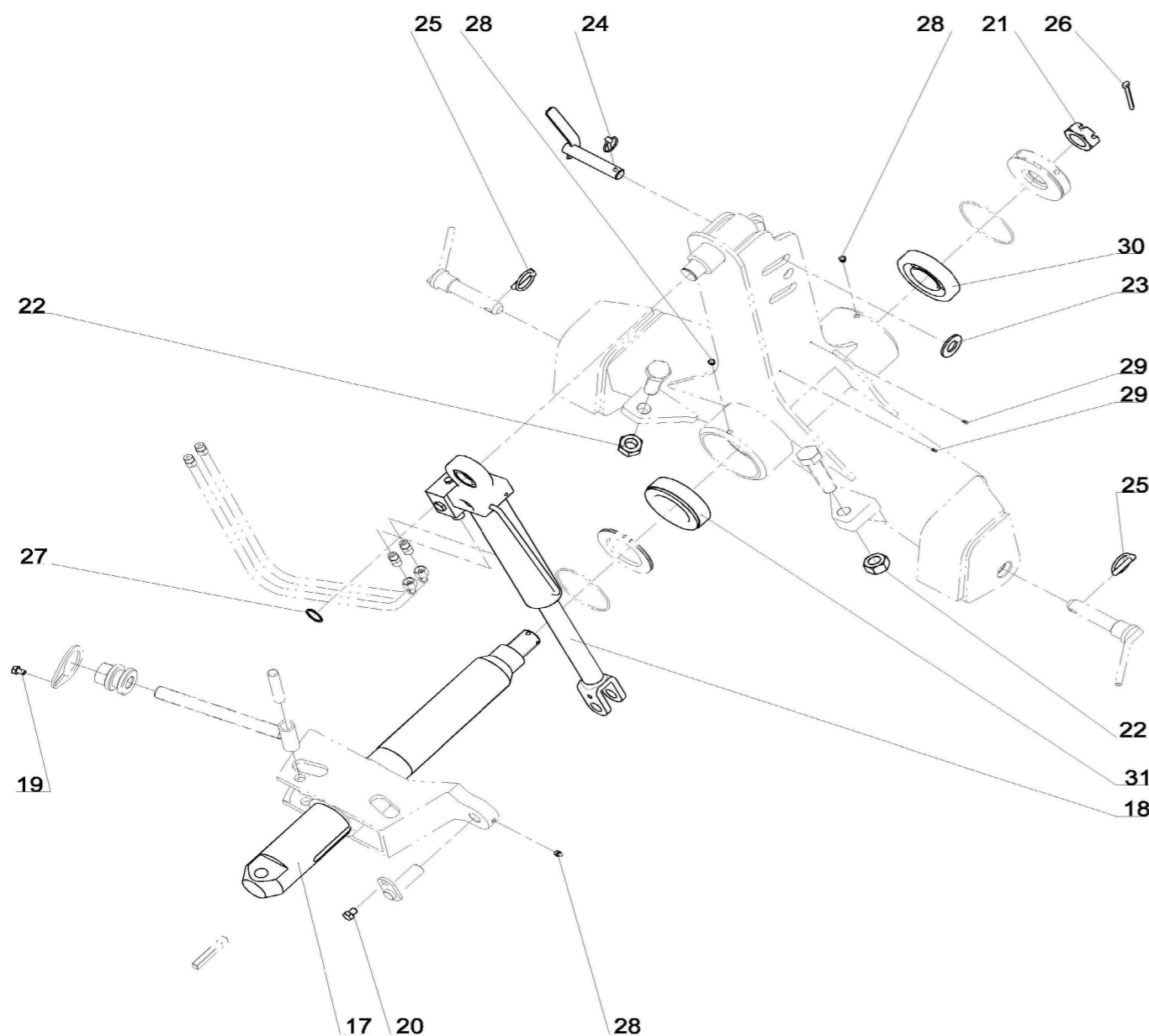

Repere	Quantite	Reference	Designation
17	1	1 123 417	Fusee Avant-Train Drehachse (Pflugturm)
18	1	1 123 418	Verin de retournement Dia 63x40 C255 Drehzylinder D. 63x40 Hub255
19	1	VI 28 01	Vis H M10x16 - 8.8 Z, filet / 16 mm Schraube H M10x16 - 8.8 Z, Gewinde / 16 mm
20	1	VI 29 01	Vis H M12x16 - 8.8 Z, filet / 16 mm Schraube H M12x16 - 8.8 Z, Gewinde / 16 mm
21	1	VJ 210	Ecrou a crenaux HK M 40x 300 Kronenmutter HK M 40x 300
22	2	VJ 623	Ecrou std H M27 - pas 300 Noir Mutter std H M27 x 300 Noir
23	1	VK 512	Rondelle plate moyenne MU27 Unterlegscheibe M 27 U
24	1	VL 101	Goupille Clips Dia6 Klappsplint Dia6
25	2	VL 103	Goupille Clips Dia10 Klappsplint Dia10
26	1	VL 419	Goupille fendue V 8x80 Splint V- 8x80
27	1	VM 007	Circlips exterieur pour arbre Dia 35 mm Sicherungsring f. welle Dia 35 mm
28	3	VM 205	Graisseur droit - M10, pas150 Gerader schmiernippel - M10 x 150
29	2	VM 410	Rivet tete ronde 4x9 Rundniet 4x9
30	1	VN 30 312	Roulement a rouleaux conique Dia60x130x34 Kegelrollenlager Dia60x130x34
31	1	VN 33 017	Roulement a rouleaux conique Dia85x130x36 Kegelrollenlager Dia85x130x36



Valve PUSH-PULL M18x15 a clapet
Hydraulikstecker M18x15 a



<i>Repere</i>	<i>Quantite</i>	<i>Reference</i>	<i>Designation</i>
1	1	1 122 393	Valve a pousse M18 X 15O male PUSH-PULL ventil M18x15O

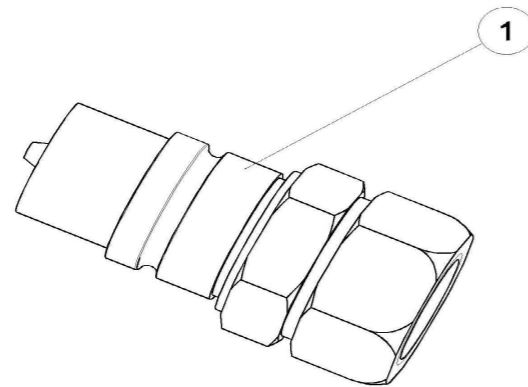



Caisson charrue
Pflug Rahmen

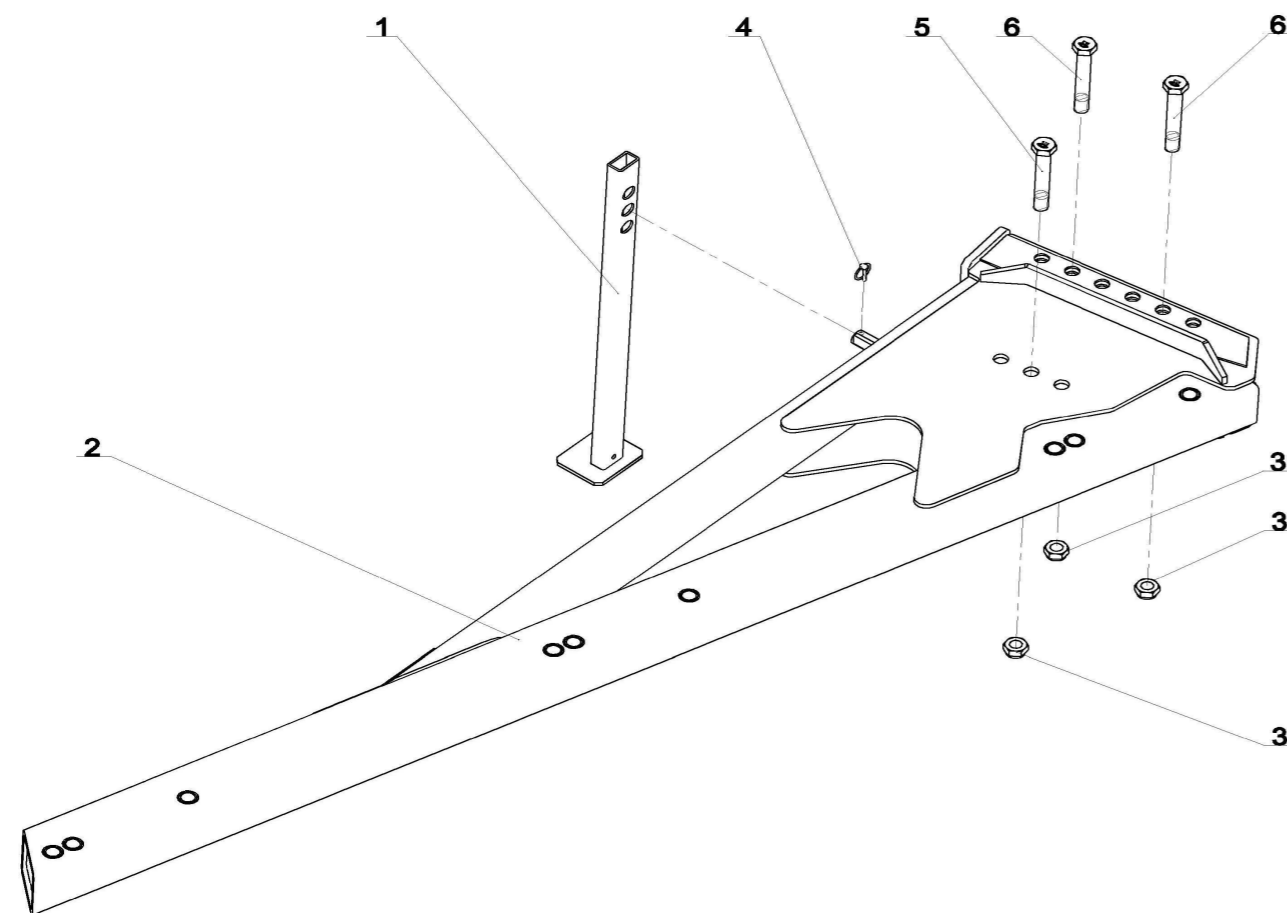

<i>Repere</i>	<i>Quantite</i>	<i>Reference</i>	<i>Designation</i>
1	1	1 123 408	Bequille charrue Abstellstutze
2	1	1 123 403	Caisson 3 Corps 1000 Rahmen 3-scharig 1000
-	1	1 123 420	Caisson 4 Corps 1000 Rahmen 4-scharig 1000
3	3	VJ 331	Ecrou frein std H M 24 - pas 300 Stoppmutter std H M 24 x 300
4	1	VL 101	Goupille Clips Dia6 Klappsplint Dia6
5	1	VI 35 15	Vis H M24x170 - 10.9 Z, filet / 36 mm Schraube H M24x170 - 10.9 Z, Gewinde / 36 mm
6	2	VI 35 17	Vis H M24x180 - 10.9 Z, filet / 36 mm Schraube H M24x180 - 10.9 Z, Gewinde / 36 mm



Securité boulon console
Konsole kpl.

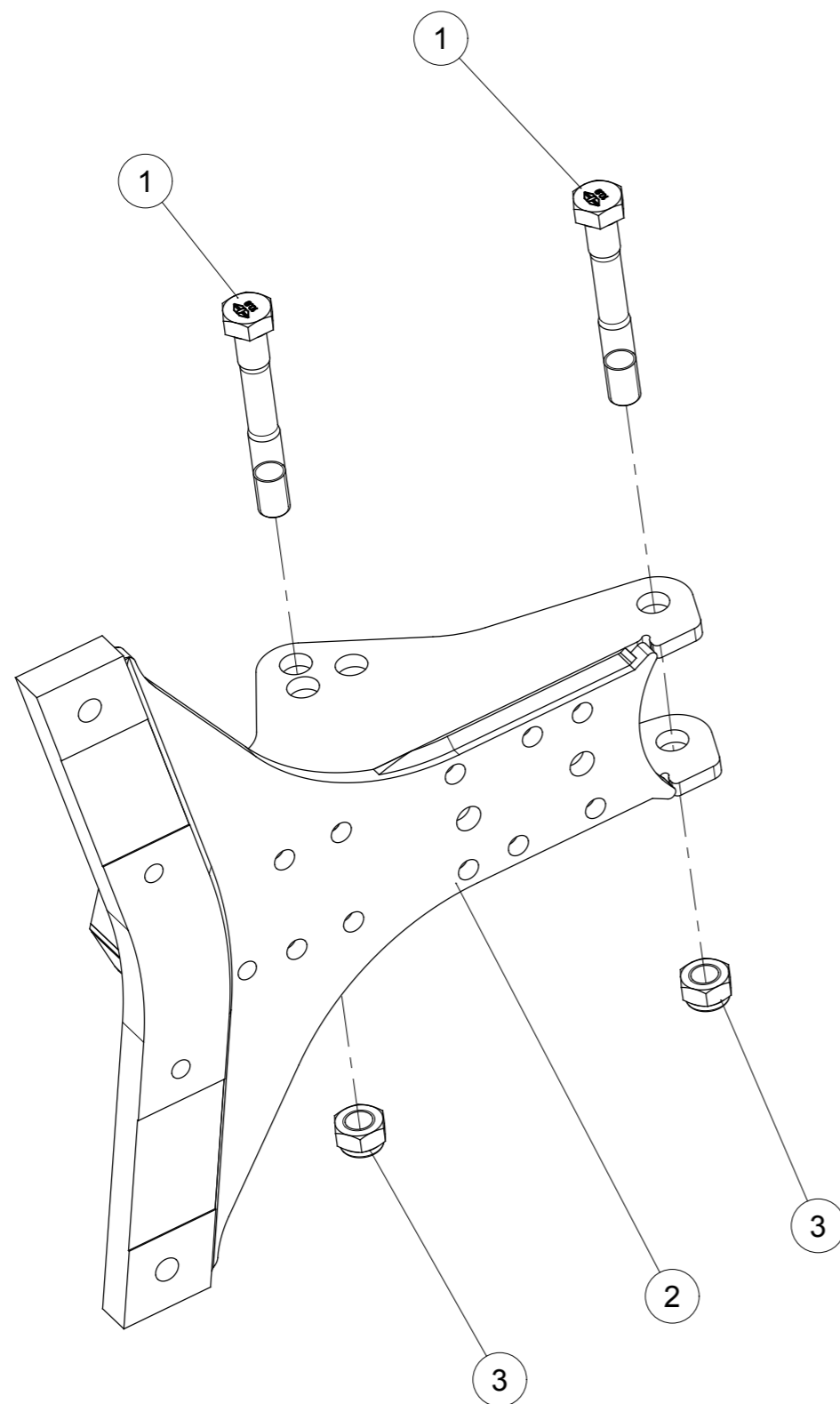

<i>Repere</i>	<i>Quantite</i>	<i>Reference</i>	<i>Designation</i>
1	2	1 118 356	Vis H M24x180 - 10.9 ZNBL, filet /36 mm Schraube H M24x180 - 10.9 ZNBL, Gewinde /36 mm
2	1	4814.00.01	console Konsole
3	2	VJ 331	Ecrou frein std H M 24 - 8 ZNBL Stopfmutter std H M 24 - 8 ZNBL

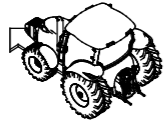

**TENDILLE 70x30 RH80 CPL.
BOGENGRINDEL 70X30 RH80 KPL.**



7010.04.01 Befestigungsschrauben kpl.- (Teilesatz)

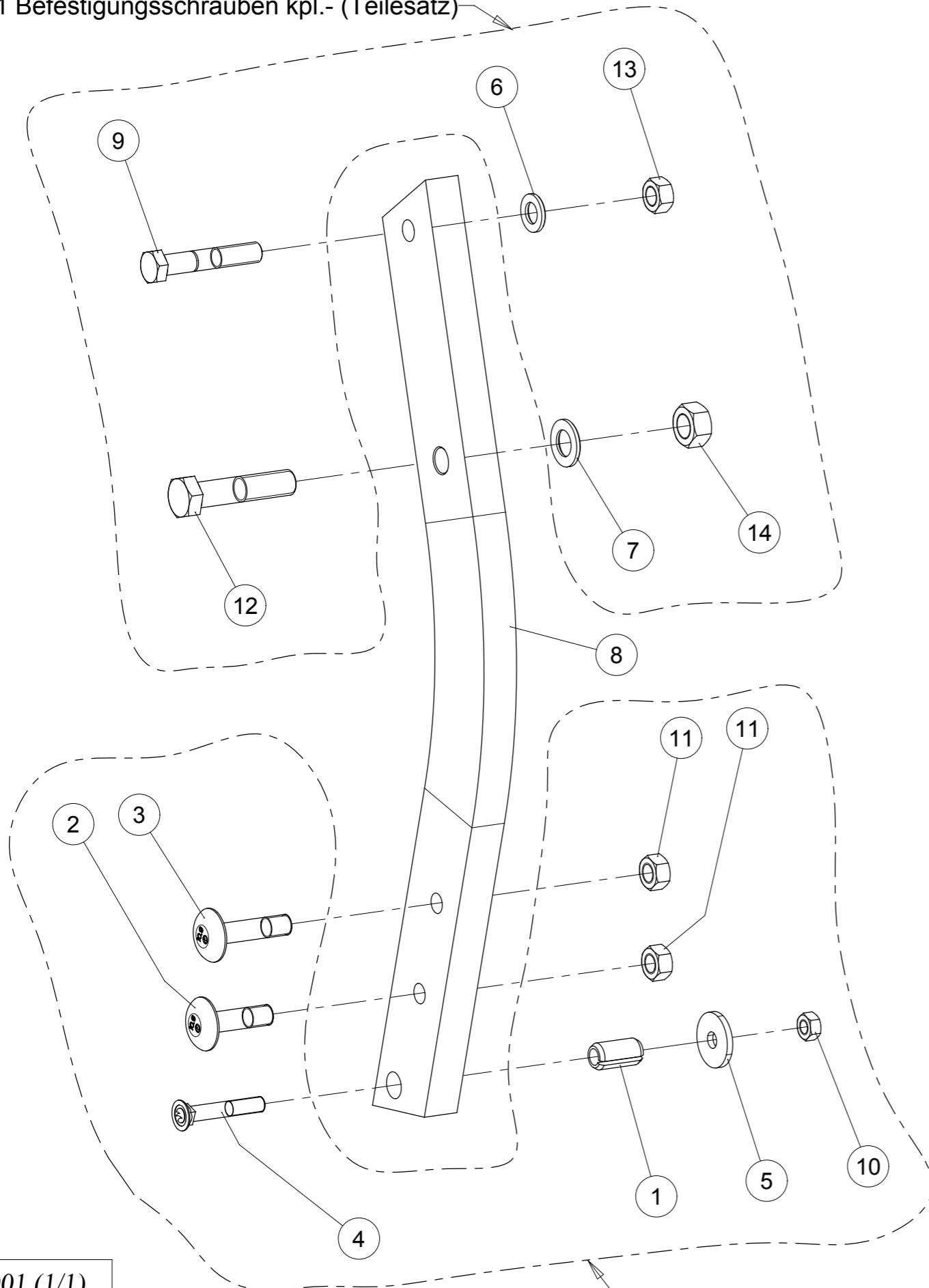

Repere	Quantite	Reference	Designation
1	1	1481D2140	Goupille elastique 21 X 40 ISO8752 SPANNSTIFT 21 X 40 ISO8752
2	1	2204.49.03	Vis M 16x60-10.9 SONDER-FL.RD-SCHR. M16x60-10.9
3	1	2204.49.12	Vis M 16x70-10.9 SONDER-FL.RD-SCHR. M16x70-10.9
4	1	2700.26.14	Vis a tête fraisée M 12 X 75-10.9 SENKSCHR.M 12 X 75-10.9 VIERK.
5	1	6436.60.03	Rondelle C-13 Scheibe C-13
6	1	6916D17A	Rondelle 17 EN14399-6 Z SCHEIBE 17 EN14399-6 Z
7	1	6916D21A	Rondelle 21 Z Scheibe 21 Z
8	1	7010.01.01	Etancon 70x30 RH80 BOGENGRINDEL 70X30 RH80 VERG.
9	1	7010.02.01	Vis Hex.M16x1.5x90 - 10.9 avec entaille Scherschraube mit Kerbe M16x1.5x90 - 10.9
10	1	934D12M	Ecrou std H M12 - pas 175 Noir Mutter std H M12 Blank 12.9
11	2	934D16NA	Ecrou std H M16 - pas 200 Zingue Mutter std H M16 Verzinkt 10.9
12	1	960D201590NA	Vis hex. M20x1.5x90 ZNBL 6KTS M20x1.5x90 Verzinkt
13	1	VJ 638	Ecrou HU M16 - 8 ZNBL - pas 150 Mutter HU M16 - 8 ZNBL - Steigung 150
14	1	VJ 639	Ecrou HU M20 - 10 ZNBL - pas 150 Mutter HU M20 - 10 ZNBL - Steigung 150

G7010/001 (1/1)

G2722/003 Grindelbefestigungsteile (30 Dick) - (Teilesatz)

09-Jun-15

Revision :
M a J :



Vis de fixation cpl. T30 D16/20
 Befestigungsschrauben Kpl. T30 D16/20

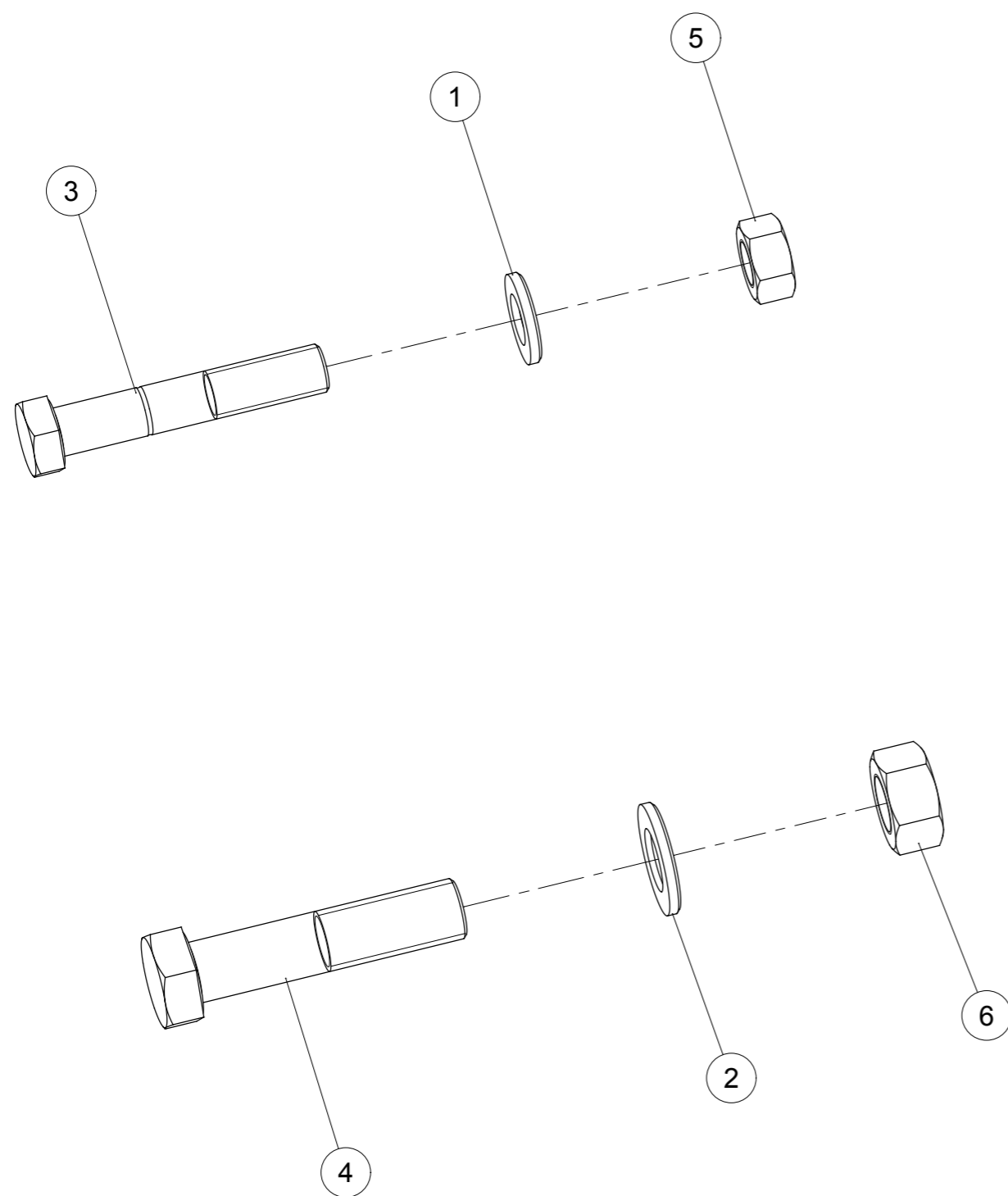

Repere	Quantite	Reference	Designation
1	1	6916D17A	Rondelle 17 EN14399-6 Z SCHEIBE 17 EN14399-6 Z
2	1	6916D21A	Rondelle 21 Z Scheibe 21 Z
3	1	7010.02.01	Vis Hex.M16x1.5x90 - 10.9 avec entaille Scherschraube mit Kerbe M16x1.5x90 - 10.9
4	1	960D201590NA	Vis hex. M20x1.5x90 ZNBL 6KTS M20x1.5x90 Verzinkt
5	1	VJ 638	Ecrou HU M16 - 8 ZNBL - pas 150 Mutter HU M16 - 8 ZNBL - Steigung 150
6	1	VJ 639	Ecrou HU M20 - 10 ZNBL - pas 150 Mutter HU M20 - 10 ZNBL - Steigung 150



**Kit de visserie pour tendille (épaisse 30) cpl.
Grindelbefestigungsteile (30 Dick) kpl.**

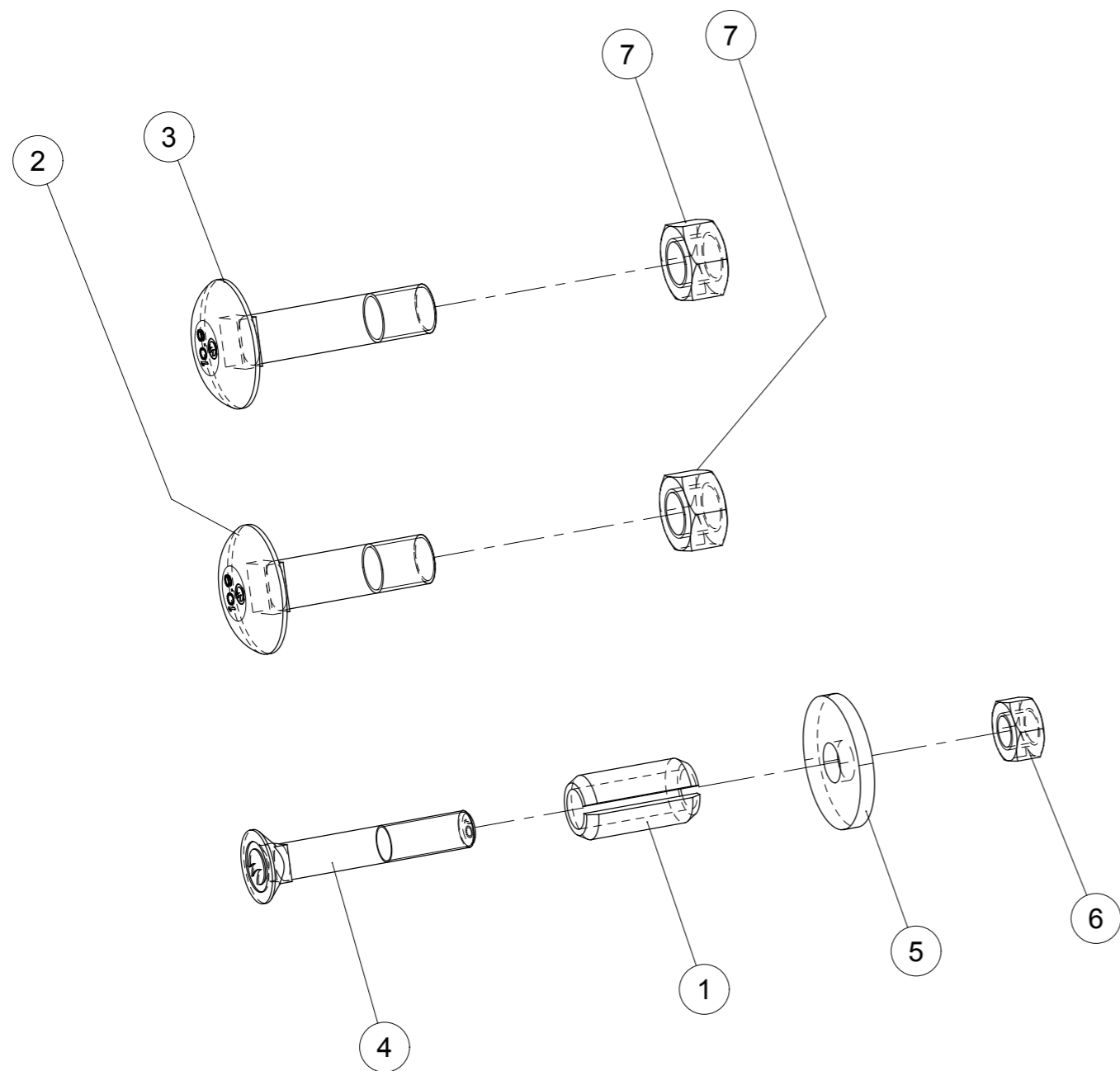

Repere	Quantite	Reference	Designation
1	1	1481D2140	Goupille elastique 21 X 40 ISO8752 SPANNSTIFT 21 X 40 ISO8752
2	1	2204.49.03	Vis M 16x60-10.9 SONDER-FL.RD-SCHR. M16x60-10.9
3	1	2204.49.12	Vis M 16x70-10.9 SONDER-FL.RD-SCHR. M16x70-10.9
4	1	2700.26.14	Vis a tête fraisée M 12 X 75-10.9 SENKSCHR.M 12 X 75-10.9 VIERK.
5	1	6436.60.03	Rondelle C-13 Scheibe C-13
6	1	934D12M	Ecrou std H M12 - pas 175 Noir Mutter std H M12 Blank 12.9
7	2	934D16NA	Ecrou std H M16 - pas 200 Zingue Mutter std H M16 Verzinkt 10.9



Corps de labour
Vollkörper



Bild Ref. Fig.	Bestellnr. Part-No. Référence	Stck. Qty. Qte.	Bezeichnung	Technische Angaben Technical data Données techniques	Description	Désignation
1	2722.02.01	1	Körperbrust	CBP-294 O	Frog	Sep
1	2722.02.02	1	Körperbrust	CBP-294 OL	Frog	Sep
	BP321P		Körper	BP-321 P(L)	Body	Corps de labour
	BP350O		Körper	BP-350 O(L)	Body	Corps de labour
2	2700.54.01	1	Plasma-Schar	SSP-293 OEP	Share	Soc
2	2700.54.02	1	Plasma-Schar	SSP-293 OELP	Share	Soc
2	2700.48.01	1	Schnabelschar	SSP-293 OE	Share	Soc
2	2700.48.02	1	Schnabelschar	SSP-293 OEL	Share	Soc
2	2700.49.01	1	RABID-Schar	SSP-293 OEZ	Share	Soc
2	2700.49.02	1	RABID-Schar	SSP-293 OELZ	Share	Soc
2	2700.11.01	1	Spitzschar	SP-271 P	Share	Soc
2	2700.11.02	1	Spitzschar	SP-271 P L	Share	Soc
2a	2701.11.01	1	Diamantschar	DSP-293 O	Share	Soc
2a	2701.11.02	1	Diamantschar	DSP-293 O L	Share	Soc
	BP322P		Körper	BP-322 P(L)	Body	Corps de labour
	BP351O		Körper	BP-351 O(L)	Body	Corps de labour
2	2700.55.01	1	Plasma-Schar	SSP-294 OEP	Share	Soc
2	2700.55.02	1	Plasma-Schar	SSP-294 OEPL	Share	Soc
2	2707.05.01	1	Schnabelschar	SSP-294 OE	Share	Soc
2	2707.05.02	1	Schnabelschar	SSP-294 OEL	Share	Soc
2	2700.50.01	1	RABID-Schar	SSP-294 OEZ	Share	Soc
2	2700.50.02	1	RABID-Schar	SSP-294 OELZ	Share	Soc
2	2707.02.01	1	Spitzschar	SP-272 P	Share	Soc
2	2707.02.02	1	Spitzschar	SP-272 PL	Share	Soc
3	2701.11.03	1	Unterlage	URP-22 (DSP-293 O/OL)	Shim	Cale
	BP321P		Körper	BP-321 P(L)	Body	Corps de labour
	BP350O		Körper	BP-350 O(L)	Body	Corps de labour
4	2701.33.01	1	Schar für Wechselsp.	SSP-293 OSE	Share	Soc
4	2701.33.02	1	Schar für Wechselsp.	SSP-293 OSEL	Share	Soc
	BP322P		Körper	BP-322 P(L)	Body	Corps de labour
	BP351O		Körper	BP-351 O(L)	Body	Corps de labour
4	2707.04.01	1	Schar für Wechselsp.	SSP-294 OSE	Share	Soc
4	2707.04.02	1	Schar für Wechselsp.	SSP-294 OSEL	Share	Soc
5	2701.12.01	1	Wechselspitze	MP-293	Bolt-on point	Pointe
5	2701.12.02	1	Wechselspitze	MP-293 L	Bolt-on point	Pointe
6	2700.41.13	2	Kegelschraube	M12x37 -12.9	Bolt	Vis
6	934D12M	2	Sechskantmutter	M12 ISO4032-12	Hex. nut	Ecrou 6 pans
7	2720.05.00	1	Pappscheibe	Ø4,5 mm	Washer	Rondelle



Corps de labour
Vollkörper

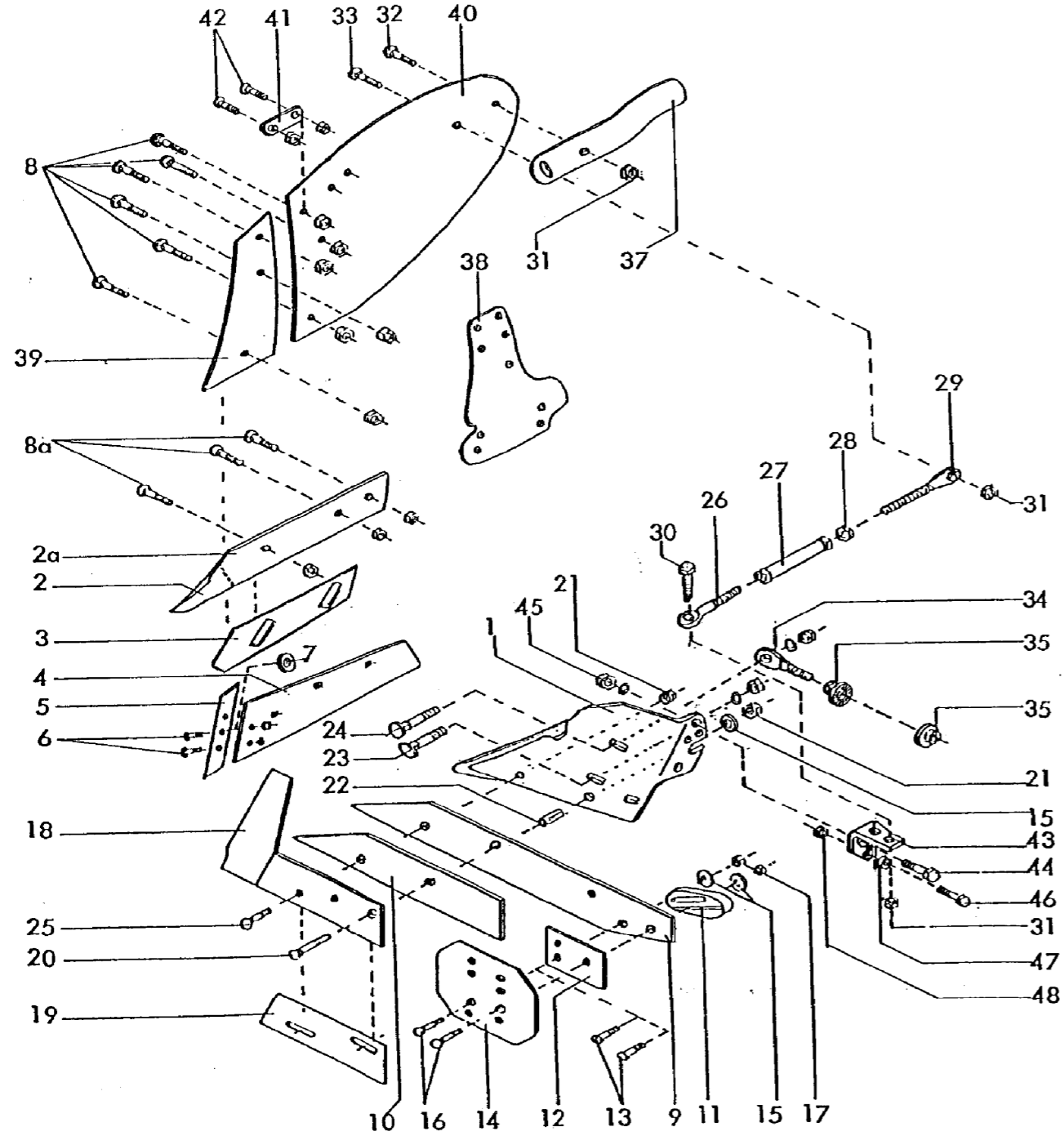

Bild Ref. Fig.	Bestellnr. Part-No. Référence	Stck. Qty. Qte.	Bezeichnung	Technische Angaben Technical data Données techniques	Description	Désignation
8	2700.26.03	6	Senkschraube	M12x30-10.9 4kt.	C sunk screw	Vis tête noyée
8,8a	934D12N	9	Sechskantmutter	M12 ISO4032-10	Hex. nut	Ecrou 6 pans
8a	2700.26.05	3	Senkschraube	M12x35-10.9 4kt.	C sunk screw	Vis tête noyée
9	2701.14.00	1	Anlage lang	WP-292 O	Long landside	Contresep long
10	2701.15.00	1	Anlage kurz	VP-292 O	Short landside	Contresep court
11	2700.30.01	1	Schleifsohle	UP-9	Heel	Talon
11	2700.30.02	1	Schleifsohle	UP-9 L	Heel	Talon
12	2708.15.00	1	Anlagenschoner	XP-4	Landside wearplate	Plaque latérale
13	2700.26.05	2	Senkschraube	M12x35-10.9 4kt.	C sunk screw	Vis tête noyée
14	2708.14.00	1	Anlagenschoner	XP-6	Landside wearplate	Plaque latérale
15	6436.60.03	2,3	Scheibe	C-13	Washer	Rondelle
16	2700.26.17	1	Senkschraube	M12x45-10.9 4kt.	C sunk screw	Vis tête noyée
16	2700.26.10	2	Senkschraube	M12x55-10.9 4kt.	C sunk screw	Vis tête noyée
17	934D12N	1,2	Sechskantmutter	M12 ISO4032-10	Hex. nut	Ecrou 6 pans
18	2722.05.01	1	Anlagensech	NG-71	Wing coulter	Coutre de contresep
18	2722.05.02	1	Anlagensech	NG-71 L	Wing coulter	Coutre de contresep
19	2701.21.00	1	Blechnerunterlage	NG-71 (L)	Shim	Cale
20	2700.26.15	1	Senkschraube	M12x85-10.9	C sunk screw	Vis tête noyée
21	934D12N	2	Sechskantmutter	M12 ISO4032-10	Hex. nut	Ecrou 6 pans
22	1481D2145	1	Spannstift	21x45 DIN1481	Dowel Pin	Goupille serrage
22	1481D2150	1	Spannstift	21x50 DIN1481	Dowel Pin	Goupille serrage
22	1481D2155	1	Spannstift	21x55 DIN1481	Dowel Pin	Goupille serrage
22	1481D2160	1	Spannstift	21x60 DIN1481	Dowel Pin	Goupille serrage
23	2204.49.06	1	Sonderflachrundschr.	M16X70-8.8	Bolt	Vis
24	2204.49.09	1	Sonderflachrundschr.	M16X85-10.9	Bolt	Vis
24	127DB16A	2	Federring	B16 DIN127 vz.	Springwasher	Rondelle grower
24	934D16PA	2	Sechskantmutter	M16 ISO4032-8 verz.	Hex. nut	Ecrou 6 pans
25	933D1240N	1	Sechskantschraube	M12x40 ISO4017-10.9	Hex. bolt	Vis 6 pans
26-29	2700.19.01	1	SPANNSCHLOß		TURNBUCKLE CPL.	TIRANT CPL.
26	2700.17.02	1	Gewindeende li.		Eyebolt l.h.	Piton filete gauche
27	2700.20.00	1	Spannschloßmutter	L=190	Turnbuckle nut	Ecrou tendeur
28	934D20PA	1	Sechskantmutter	M20 ISO4032-8 vz.	Hex. nut	Ecrou 6 pans
29	2700.21.01	1	Gewindeende rechts	L=260	Eyebolt	Piton filete
30	931D1240N	1	Sechskantschraube	M12x40 DIN931-10.9	Hex. bolt	Vis 6 pans
31	980DV12N	1	Sicherungsmutter	VM12 DIN980-10	Lock nut	Ecrou frein
32	2700.26.05	1	Senkschraube	M12x35-10.9 4kt.	C sunk screw	Vis tête noyée
33	2700.26.09	1	Senkschraube	M12x50-10.9 4kt.	C sunk screw	Vis tête noyée
34,35	2720.09.02	1	KÖRPERSTELLSCHR.	M20, Bohrung Ø16	ADJUSTING SCREW	VIS DE REGLAGE



Corps de labour
Vollkörper

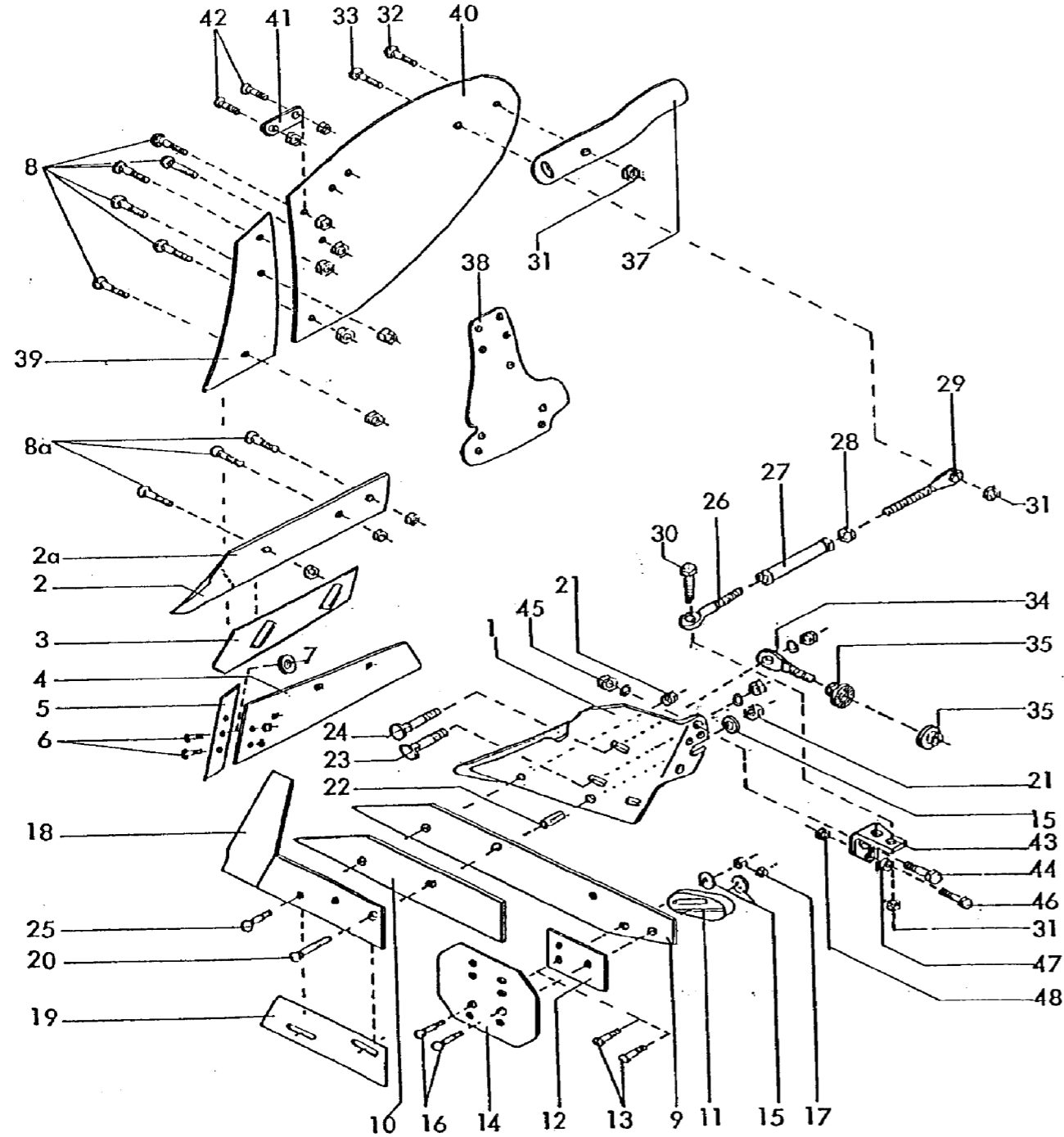

Bild Ref. Fig.	Bestellnr. Part-No. Référence	Stck. Qty. Qte.	Bezeichnung	Technische Angaben Technical data Données techniques	Description	Désignation
34	2720.07.01	1	Körperstellschraube	M20, Bohrung Ø16	Adjusting screw	Vis de réglage
35	934D20N	2	Sechskantmutter	M20-10	Hex. nut	Ecrou 6 pans
35	2720.11.01	2	Sperrkantscheibe	20 M	Washer	Rondelle
37	2701.19.01	1	Abstreifer	FP-78	Scraper	Décrottoir
37	2701.19.02	1	Abstreifer	FP-78 L	Scraper	Décrottoir
38	2701.09.00	2	Streichblechunterlage	URP-154	Shim	Cale
39	BP321/322P	1	Körper	BP-321, 322 P(L)	Body	Corps de labour
39	2701.07.01	1	Streichblech	VRP-292 O	Shin	Versoir
39	2701.07.02	1	Streichblech	VRP-292 O L	Shin	Versoir
40	2701.08.01	1	Streichblech	HRP-327 P	Shin	Versoir
40	2701.08.02	1	Streichblech	HRP-327 P L	Shin	Versoir
	BP350/351O		Körper	BP-350, 351 O(L)	Body	Corps de labour
39	2758.01.01	1	Streichblech	VRP-350 O	Shin	Versoir
39	2758.01.02	1	Streichblech	VRP-350 OL	Shin	Versoir
40	2758.02.01	1	Streichblech	HRP-350 O	Shin	Versoir
40	2758.02.02	1	Streichblech	HRP-350 OL	Shin	Versoir
41	2704.03.00	1	Verbindungsglasche		Latch	Plat
42	2700.26.01	2	Senkschraube	M12x25 -5.6 4kt.	C sunk screw	Vis tête noyée
42	934D12P	2	Sechskantmutter	M12 DIN 934-8	Hex. nut	Ecrou 6 pans
43	2720.06.05	1	Strebenhalter, rechts		Bracket	Support
43	2720.06.06	1	Strebenhalter, links		Bracket	Support
44	933D2045P	1	Sechskantschraube	M20x45 ISO4017-8.8	Hex. bolt	Vis 6 pans
45	934D20P	1	Sechskantmutter	M20 DIN934-8	Hex. nut	Ecrou 6 pans
45	127DB20A	1	Federring	B20 DIN127 vz.	Springwasher	Rondelle grower
46	933D1240N	1	Sechskantschraube	M12x40 ISO4017-10.9	Hex. bolt	Vis 6 pans
47	126D14	1	Scheibe	14 ISO7091	Washer	Rondelle
48	934D12N	1	Sechskantmutter	M12 ISO4032-10	Hex. nut	Ecrou 6 pans

Corps a versoirs claire-voie
Streifenkörper

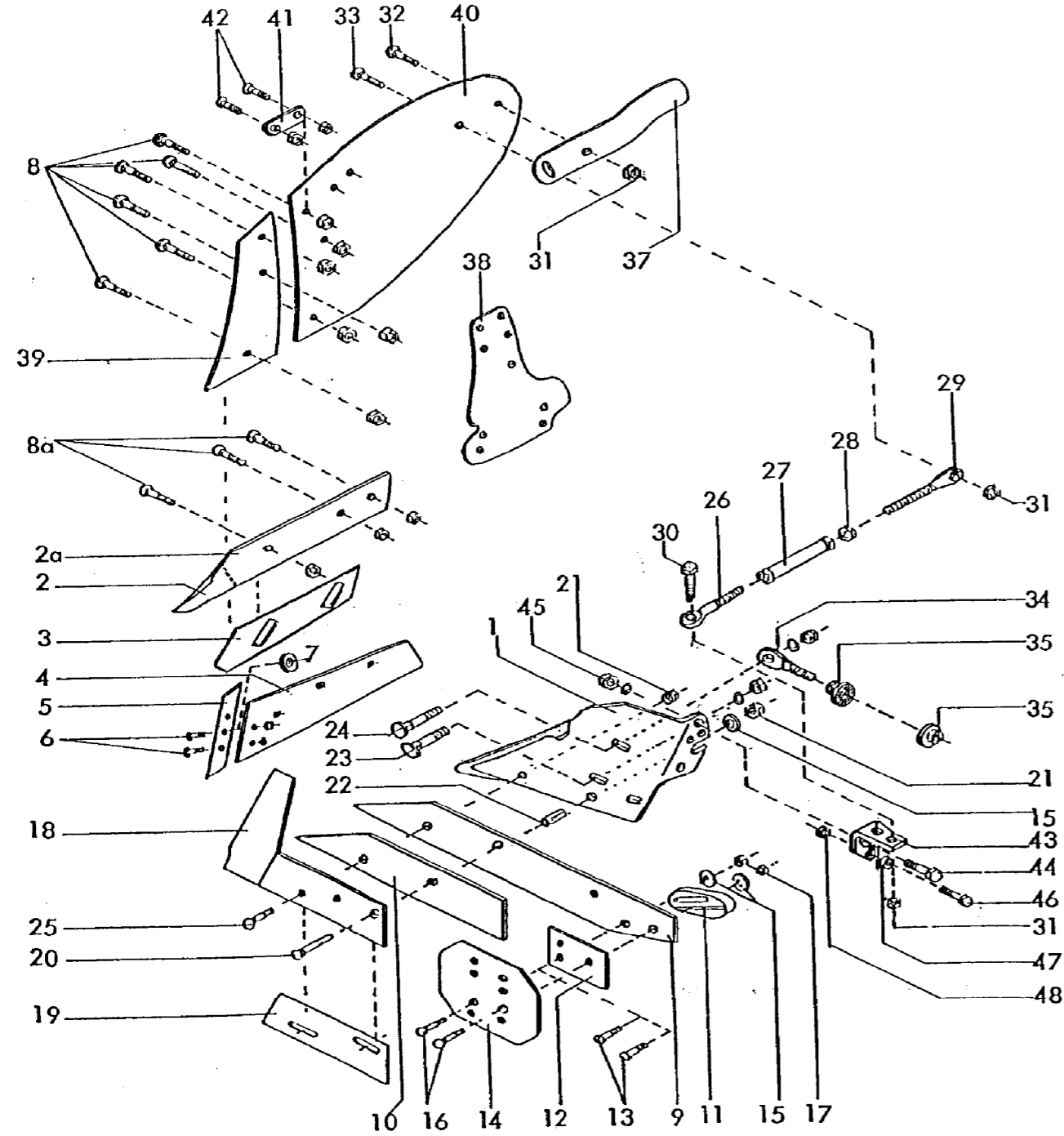

Bild Ref. Fig.	Bestellnr. Part-No. Référence	Stck. Qty. Qte.	Bezeichnung	Technische Angaben Technical data Données techniques	Description	Désignation
1	2759.01.01	1	Körperbrust	BP-330 W	Frog	Sep
1	2759.01.02	1	Körperbrust	BP-330 WL	Frog	Sep
1a	2751.02.05	1	Anlagenspitze	YP-350 W	Bolt-on point	Pointe
1b	2700.26.05	2	Senkschraube	M12x35-10.9 4kt.	C sunk screw	Vis tête noyée
1b	934D12M	2	Sechskantmutter	M12 ISO4032-12	Hex. nut	Ecrou 6 pans
2	2759.07.01	1	Streichblech	VRP-330 W	Shin	Versoir
2	2759.07.02	1	Streichblech	VRP-330 WL	Shin	Versoir
3	2759.10.01	1	Streichblechunterlage	T=2 mm	Shim	Cale
3a	2759.10.02	3	Streichblechunterlage	T=2 mm	Shim	Cale
3b	2759.10.03	1	Streichblechunterlage	T=2 mm	Shim	Cale
4	2700.26.03	2	Senkschraube	M12x30-10.9 4kt.	C sunk screw	Vis tête noyée
4	934D12PA	2	Sechskantmutter	M12 ISO4032-8 vz.	Hex. nut	Ecrou 6 pans
	BP330WS		Streifenkörper	BP-330 WS(L)	Slatted body	Corps à versoir claire-voie
5	2751.28.01	1	Plasma-Schar	SSP-350 WEP	Share	Soc
5	2751.28.02	1	Plasma-Schar	SSP-350 WELP	Share	Soc
5	2751.23.01	1	Schnabelschar	SSP-350 WE	Share	Soc
5	2751.23.02	1	Schnabelschar	SSP-350 WEL	Share	Soc
6	2751.22.01	1	Schar für Wechselsp.	SSP-350 WSE	Share	Soc
6	2751.22.02	1	Schar für Wechselsp.	SSP-350 WSEL	Share	Soc
7	2751.09.01	1	Wechselspitze	MP-350	Bolt-on point	Pointe
7	2751.09.02	1	Wechselspitze	MP-350 L	Bolt-on point	Pointe
	BP331WS		Streifenkörper	BP-331 WS(L)	Slatted body	Corps à versoir claire-voie
5	2751.30.01	1	Plasma-Schar	SSP-351 WEP	Share	Soc
5	2751.30.02	1	Plasma-Schar	SSP-351 WELP	Share	Soc
8	2700.26.03	4	Senkschraube	M12x30-10.9 4kt.	C sunk screw	Vis tête noyée
8a	2700.41.13	2	Kegelschraube	M12x37 -12.9	Bolt	Vis
8a	934D12M	6	Sechskantmutter	M12 ISO4032-12	Hex. nut	Ecrou 6 pans
9	2751.03.05	1	Anlage lang	WP-351 W	Long landside	Contresep long
10	2751.03.06	1	Anlage kurz	VP-351 W	Short landside	Contresep court
11	2700.30.01	1	Schleifsohle	UP-9	Heel	Talon
11	2700.30.02	1	Schleifsohle	UP-9 L	Heel	Talon
12	2708.15.00	1	Anlagenschoner	XP-4	Landside wearplate	Plaque latérale
13	2700.41.13	2	Kegelschraube	M12x37 -12.9	Bolt	Vis
14	2708.14.00	1	Anlagenschoner	XP-6	Landside wearplate	Plaque latérale
14	2708.14.01	1	Anlagenschoner	XP-61	Landside wearplate	Plaque latérale
15	6436.60.03	2,3	Scheibe	C-13	Washer	Rondelle
16	2700.26.17	1	Senkschraube	M12x45-10.9 4kt.	C sunk screw	Vis tête noyée
16	2700.26.10	2	Senkschraube	M12x55-10.9 4kt.	C sunk screw	Vis tête noyée

Corps a versoirs claire-voie
Streifenkörper

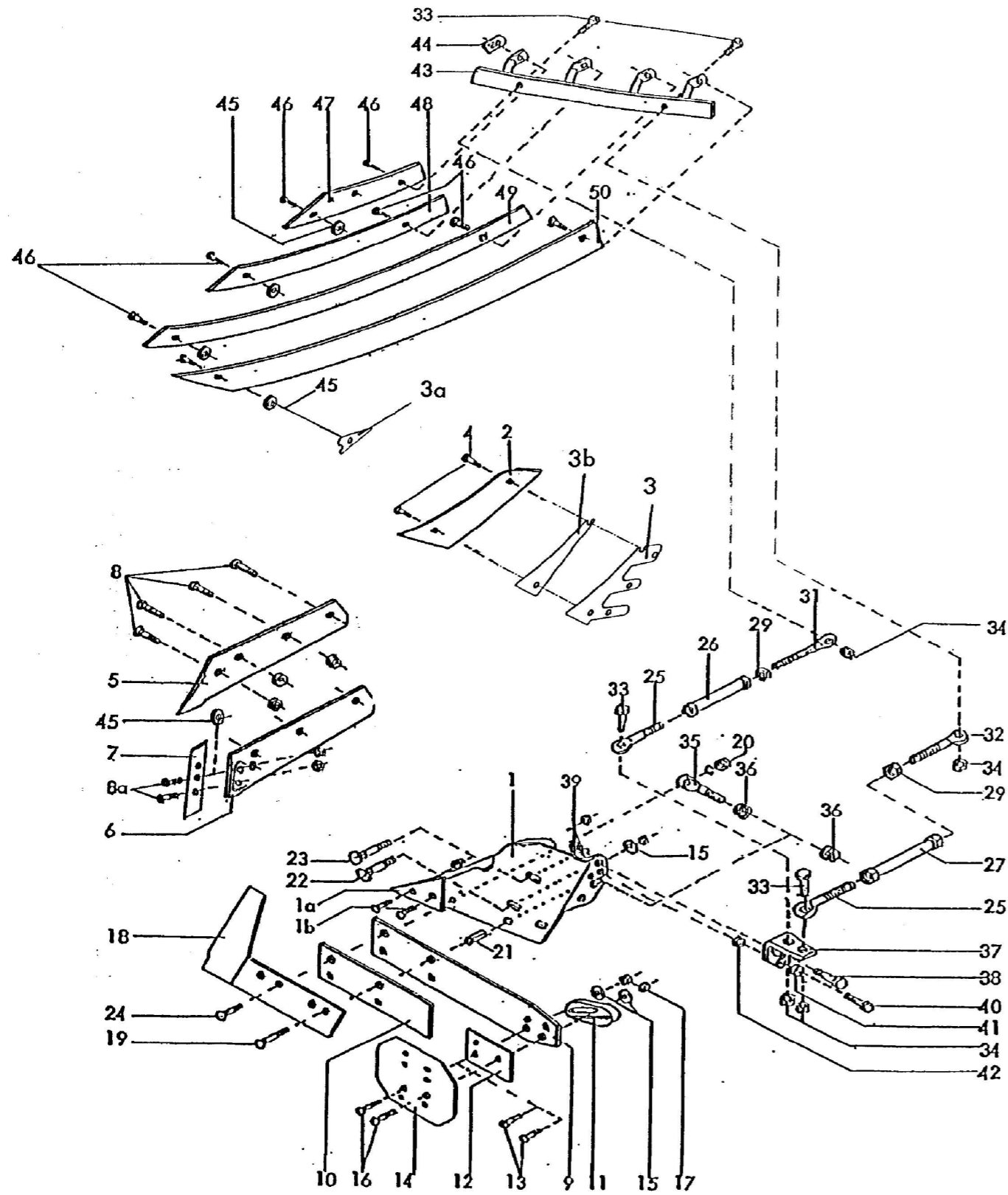

Bild Ref. Fig.	Bestellnr. Part-No. Référence	Stck. Qty. Qte.	Bezeichnung	Technische Angaben Technical data Données techniques	Description	Désignation
17	934D12N	1,2	Sechskantmutter	M12 ISO4032-10	Hex. nut	Ecrou 6 pans
18	2751.10.01	1	Anlagensech	NG-35	Wing coulter	Coutre de contresep
18	2751.10.02	1	Anlagensech	NG-35 L	Wing coulter	Coutre de contresep
19	2700.26.15	1	Senkschraube	M12x85-10.9	C sunk screw	Vis tête noyee
20	934D12N	2	Sechskantmutter	M12 ISO4032-10	Hex. nut	Ecrou 6 pans
21	1481D2145	1	Spannstift	21x45 DIN1481	Dowel Pin	Goupille serrage
21	1481D2150	1	Spannstift	21x50 DIN1481	Dowel Pin	Goupille serrage
21	1481D2155	1	Spannstift	21x55 DIN1481	Dowel Pin	Goupille serrage
21	1481D2160	1	Spannstift	21x60 DIN1481	Dowel Pin	Goupille serrage
22	2204.49.08	1	Sonderflachrundschr.	M16X75-10.9	Bolt	Vis
23	2204.49.09	1	Sonderflachrundschr.	M16X85-10.9	Bolt	Vis
23	127DB16A	2	Federring	B16 DIN127 vz.	Springwasher	Rondelle grower
23	934D16PA	2	Sechskantmutter	M16 ISO4032-8 verz.	Hex. nut	Ecrou 6 pans
24	2700.26.05	1	Senkschraube	M12x35-10.9 4kt.	C sunk screw	Vis tête noyee
25-31	2708.26.00	1	SPANNSCHLOß		TURNBUCKLE CPL.	TIRANT CPL.
25	2700.17.02	1	Gewindeende li.		Eyebolt l.h.	Piton filete gauche
26	2708.25.00	1	Spannschloßmutter	L=140 mm	Turnbuckle nut	Ecrou tendeur
29	934D20PA	1	Sechskantmutter	M20 ISO4032-8 vz.	Hex. nut	Ecrou 6 pans
31	2700.17.01	1	Gewindeende rechts		Eyebolt	Piton filete
25-32	2700.19.02	1	SPANNSCHLOß		TURNBUCKLE CPL.	TIRANT CPL.
25	2700.17.02	1	Gewindeende li.		Eyebolt l.h.	Piton filete gauche
27	2700.20.00	1	Spannschloßmutter	L=190	Turnbuckle nut	Ecrou tendeur
29	934D20PA	1	Sechskantmutter	M20 ISO4032-8 vz.	Hex. nut	Ecrou 6 pans
32	2700.21.02	1	Gewindeende rechts	L=300	Eyebolt	Piton filete
33	931D1240N	4	Sechskantschraube	M12x40 DIN931-10.9	Hex. bolt	Vis 6 pans
34	980DV12N	4	Sicherungsmutter	VM12 DIN980-10	Lock nut	Ecrou frein
35,36	2720.09.02	1	KÖRPERSTELLSCHR.	M20, Bohrung Ø16	ADJUSTING SCREW	VIS DE REGLAGE
35	2720.07.01	1	Körperstellschraube	M20, Bohrung Ø16	Adjusting screw	Vis de réglage
36	934D20N	2	Sechskantmutter	M20 ISO4032-10	Hex. nut	Ecrou 6 pans
36	2720.11.01	2	Sperrkantscheibe	20 M	Washer	Rondelle
37	2720.06.05	1	Strebenhalter, rechts		Bracket	Support
37	2720.06.06	1	Strebenhalter, links		Bracket	Support
38	933D2045P	1	Sechskantschraube	M20x45 ISO4017-8.8	Hex. bolt	Vis 6 pans
39	934D20P	1	Sechskantmutter	M20 DIN934-8	Hex. nut	Ecrou 6 pans
39	127DB20A	1	Federring	B20 DIN127 vz.	Springwasher	Rondelle grower
40	933D1235P	1	Sechskantschraube	M12x35 ISO4017-8.8	Hex. bolt	Vis 6 pans
41	126D14	1	Scheibe	14 ISO7091	Washer	Rondelle
42	934D12PA	1	Sechskantmutter	M12 ISO4032-8 vz.	Hex. nut	Ecrou 6 pans

Corps a versoirs claire-voie
Streifenkörper



Bild Ref. Fig.	Bestellnr. Part-No. Référence	Stck. Qty. Qte.	Bezeichnung	Technische Angaben Technical data Données techniques	Description	Désignation
43	2759.08.01	1	Abstützung, li.		Strut	Support
43	2759.08.02	1	Abstützung, re.		Strut	Support
44	2731.07.00	4	Pappscheibe	T=2,5 mm	Washer	Rondelle
45	2720.05.00	5	Pappscheibe	Ø4,5 mm	Washer	Rondelle
46	2700.41.13	8	Kegelschraube	M12x37 -12.9	Bolt	Vis
46	980DV12M	8	Sicherungsmutter	VM12 ISO7042-12	Lock nut	Ecrou frein
47	2759.03.01	1	Streifen	SRP-330 W 1	Slat	Lame de versoir
47	2759.03.02	1	Streifen	SRP-330 WL 1	Slat	Lame de versoir
48	2759.04.01	1	Streifen	SRP-330 W 2	Slat	Lame de versoir
48	2759.04.02	1	Streifen	SRP-330 WL 2	Slat	Lame de versoir
49	2759.05.01	1	Streifen	SRP-330 W 3	Slat	Lame de versoir
49	2759.05.02	1	Streifen	SRP-330 WL 3	Slat	Lame de versoir
50	2759.06.01	1	Streifen	SRP-330 W 4	Slat	Lame de versoir
50	2759.06.02	1	Streifen	SRP-330 WL 4	Slat	Lame de versoir

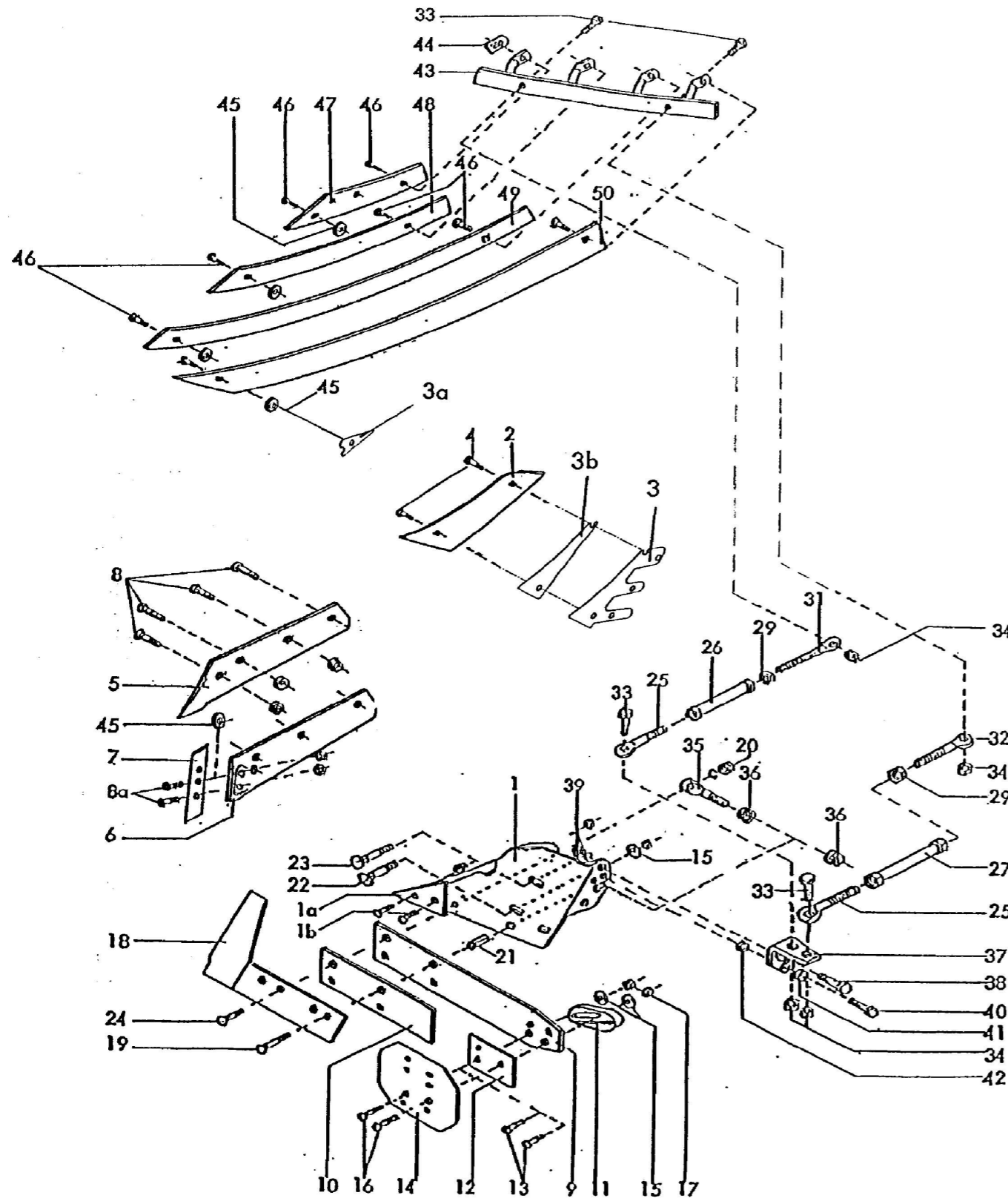

Défecteur DG-52 R
Einlegestreichblech DG-52 R

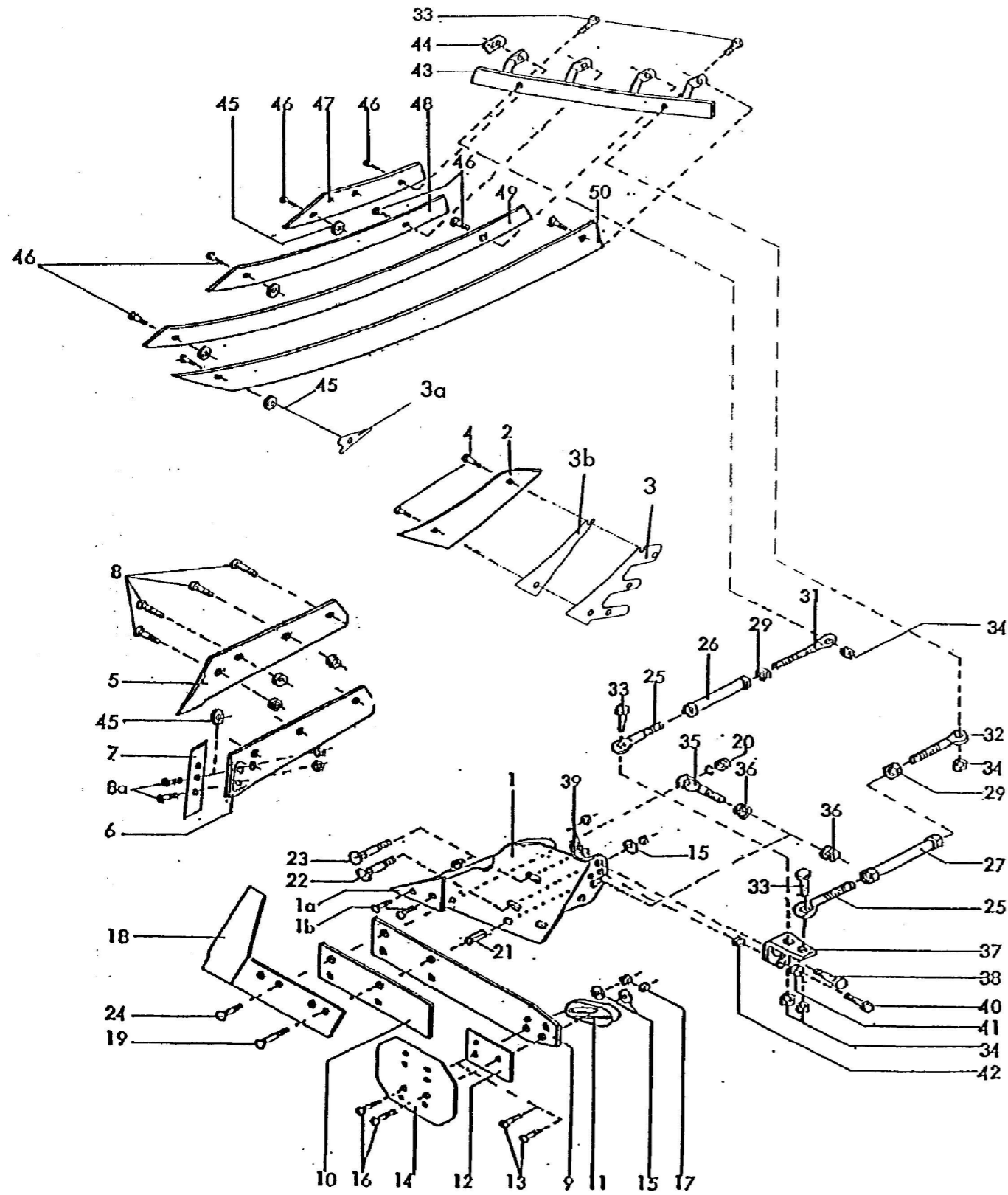
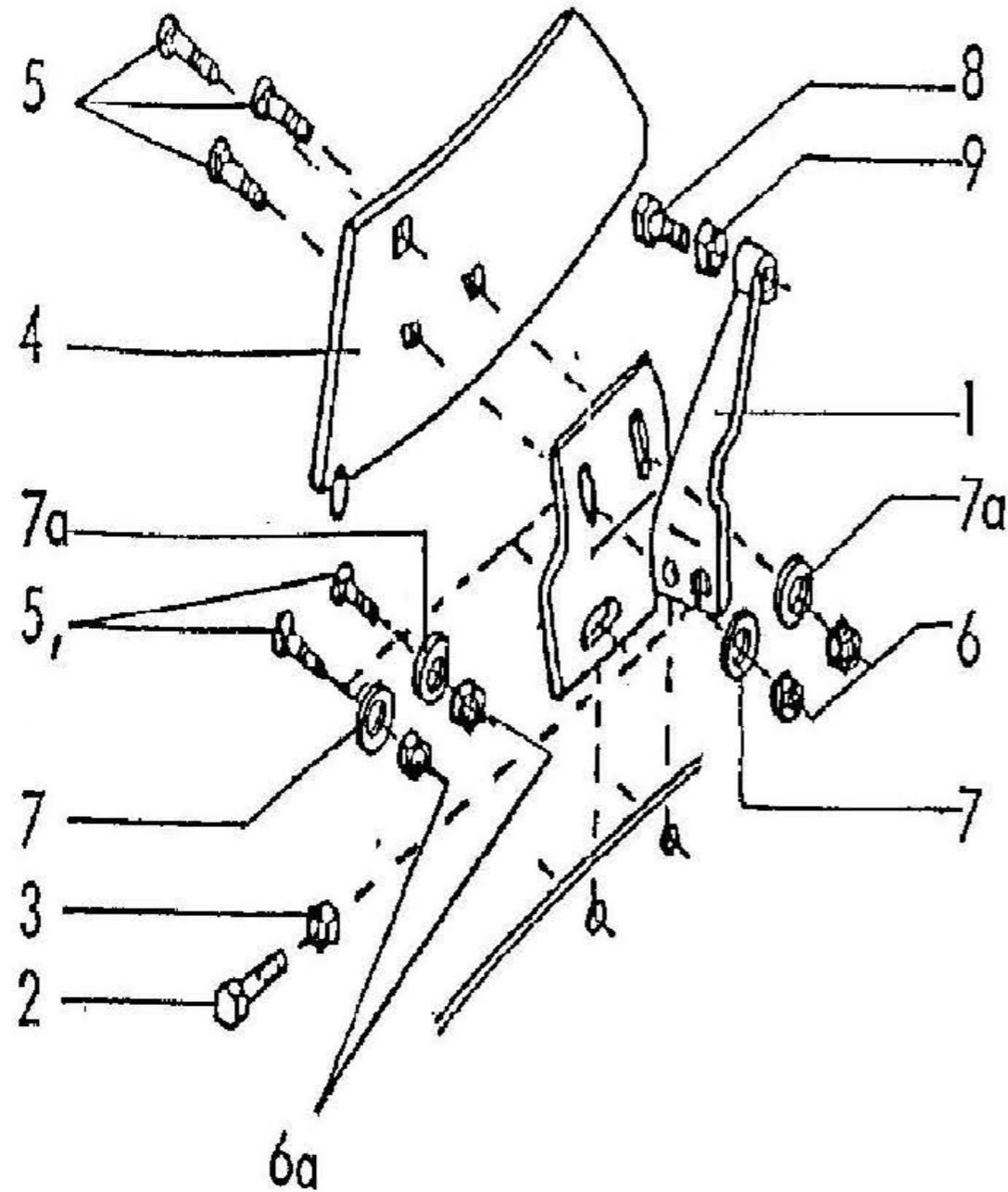

Repere	Quantite	Reference	Designation
1	1	2729.07.01	Plaque de réglage EBP-4 Einlegestellplatte EBP-4
2	1	933D1660PA	Vis Hex. M16x60 Din 933-8.8 Sechskantschraube M16x60 Din 933-8.8
3	1	936D16PA	Ecrou Hex. M16 Din936-8 Sechskantmutter M16 Din936-8
4	1	2729.08.01	Versoir PDG-52 Streichblech PDG-52
5	5	2700.26.05	Vis tête noyée M12x35-10.9 Senkschraube M12x35-10.9
6	3	934D12M	Ecrou Hex. M12 Din 934-12 Sechskantmutter M12 Din 934-12
6a	2	980DV12M	Ecrou frein VM 12 Sicherungsmutter VM 12
7	3	6436.60.03	Rondelle C-13 Scheibe C-13
7a	2	6437.00.01	Rondelle C-132 Scheibe C-132
8	1	933D1050PA	Vis Hex. M10x50-8.8 Z Sechskantschraube M10x50-8.8 verz.
9	1	934D10PA	Ecrou Hex M10 Din 934-8 Sechskantmutter M10 Din 934-8
	2	2731.07.00	Rondelle de carton 2,5 épais Pappscheibe 2,5 Dick
	2	2720.05.00	Rondelle de carton D45 Pappscheibe D45



Défecteur DG-52 L
Einlegestreichblech DG-52 L

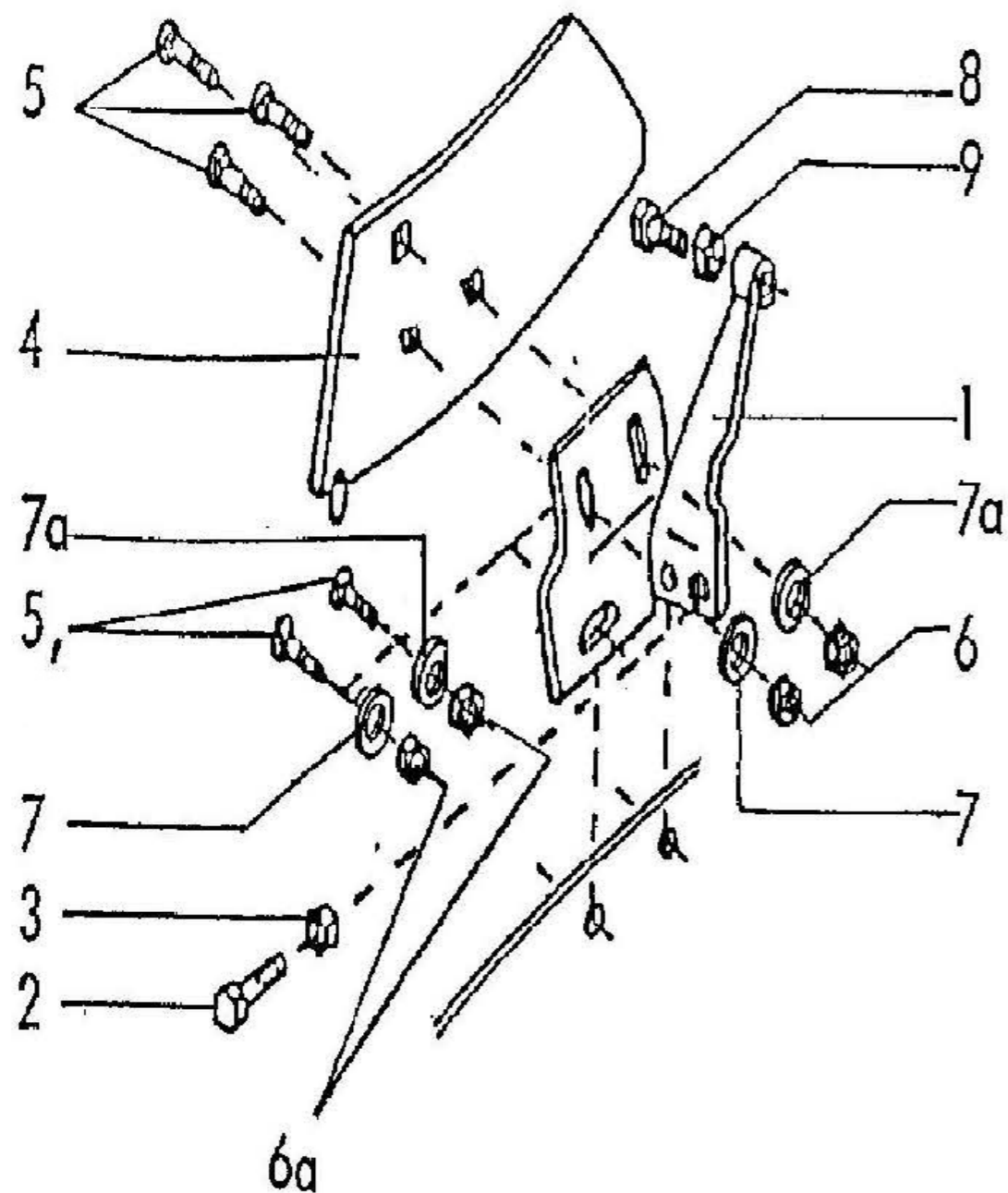

Repere	Quantite	Reference	Designation
1	1	2729.07.02	Plaque de réglage EBP-4 L Einlegestellplatte EBP-4 L
2	1	933D1660PA	Vis Hex. M16x60 Din 933-8.8 Sechskantschraube M16x60 Din 933-8.8
3	1	936D16PA	Ecrou Hex. M16 Din936-8 Sechskantmutter M16 Din936-8
4	1	2729.08.02	Versoir PDG-52 L Streichblech PDG-52 L
5	5	2700.26.05	Vis tête noyée M12x35-10.9 Senkschraube M12x35-10.9
6	3	934D12M	Ecrou Hex. M12 Din 934-12 Sechskantmutter M12 Din 934-12
6a	2	980DV12M	Ecrou frein VM 12 Sicherungsmutter VM 12
7	3	6436.60.03	Rondelle C-13 Scheibe C-13
7a	2	6437.00.01	Rondelle C-132 Scheibe C-132
8	1	933D1050PA	Vis Hex. M10x50-8.8 Z Sechskantschraube M10x50-8.8 verz.
9	1	934D10PA	Ecrou Hex M10 Din 934-8 Sechskantmutter M10 Din 934-8
	2	2731.07.00	Rondelle de carton 2,5 épais Pappscheibe 2,5 Dick
	2	2720.05.00	Rondelle de carton D45 Pappscheibe D45



Défecteur DG-51 UR
Einlegestreichblech DG-51 UR

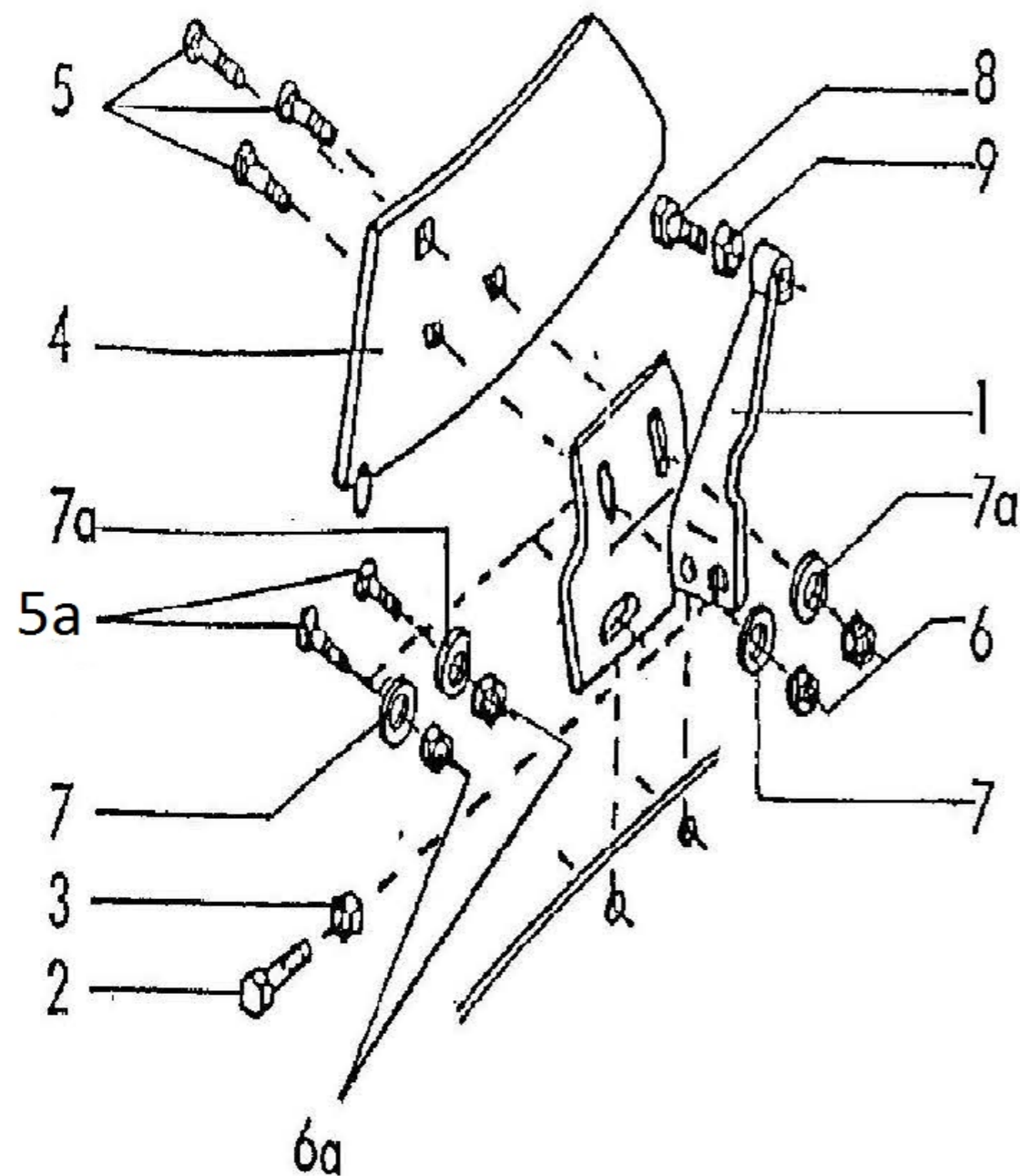

Repere	Quantite	Reference	Designation
1	1	2729.07.01	Plaque de réglage EBP-4 Einlegestellplatte EBP-4
2	1	933D1660PA	Vis Hex. M16x60 Din 933-8.8 Sechskantschraube M16x60 Din 933-8.8
3	1	936D16PA	Ecrou Hex. M16 Din936-8 Sechskantmutter M16 Din936-8
4	1	2729.01.01	Versoir PDG-51 U Streichblech PDG-51 U
5	3	2700.26.05	Vis tête noyée M12x35-10.9 Senkschraube M12x35-10.9
5a	2	2700.41.14	Vis M12x40-12.9 Kegelschraube M12x40-12.9
6	3	934D12M	Ecrou Hex. M 12 Sechskantmutter M 12
7	3	6436.60.03	Rondelle C-13 Scheibe C-13
7a	2	6437.00.01	Rondelle C-132 Scheibe C-132
8	1	933D1050PA	Vis Hex. M10x50-8.8 Z Sechskantschraube M10x50-8.8 verz.
9	1	934D10PA	Ecrou Hex M10 Din 934-8 Sechskantmutter M10 Din 934-8
	2	2731.07.00	Rondelle de carton 2,5 épais Pappscheibe 2,5 Dick
	2	2720.05.00	Rondelle de carton D45 Pappscheibe D45
6a	2	980DV12M	Ecrou frein VM 12 Sicherungsmutter VM 12

Défecteur DG-51 UL
Einlegestreichblech DG-51 UL

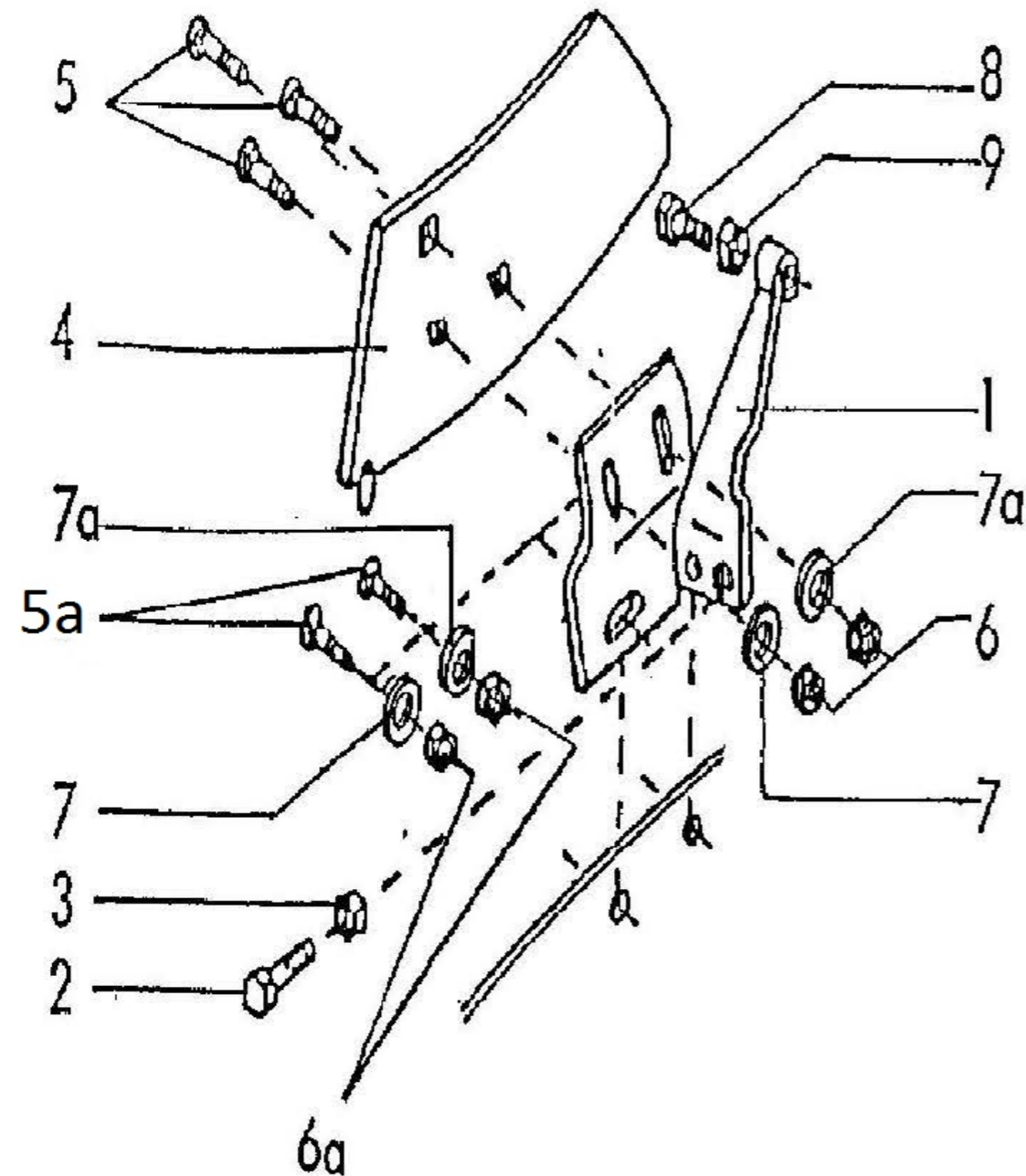

Repere	Quantite	Reference	Designation
1	1	2729.07.02	Plaque de réglage EBP-4 L Einlegestellplatte EBP-4 L
2	1	933D1660PA	Vis Hex. M16x60 Din 933-8.8 Sechskantschraube M16x60 Din 933-8.8
3	1	936D16PA	Ecrou Hex. M16 Din936-8 Sechskantmutter M16 Din936-8
4	1	2729.01.02	Versoir PDG-51 U L Streichblech PDG-51 U L
5	3	2700.26.05	Vis tête noyee M12x35-10.9 Senkschraube M12x35-10.9
5a	2	2700.41.14	Vis M12x40-12.9 Kegelschraube M12x40-12.9
6	3	934D12M	Ecrou Hex. M 12 Sechskantmutter M 12
7	3	6436.60.03	Rondelle C-13 Scheibe C-13
7a	2	6437.00.01	Rondelle C-132 Scheibe C-132
8	1	933D1050PA	Vis Hex. M10x50-8.8 Z Sechskantschraube M10x50-8.8 verz.
9	1	934D10PA	Ecrou Hex M10 Din 934-8 Sechskantmutter M10 Din 934-8
	2	2731.07.00	Rondelle de carton 2,5 épais Pappscheibe 2,5 Dick
	2	2720.05.00	Rondelle de carton D45 Pappscheibe D45
6a	2	980DV12M	Ecrou frein VM 12 Sicherungsmutter VM 12

Rasette Vari-Fix 200 B cpl.
Vorschäler Vari-Fix 200 B Kpl.

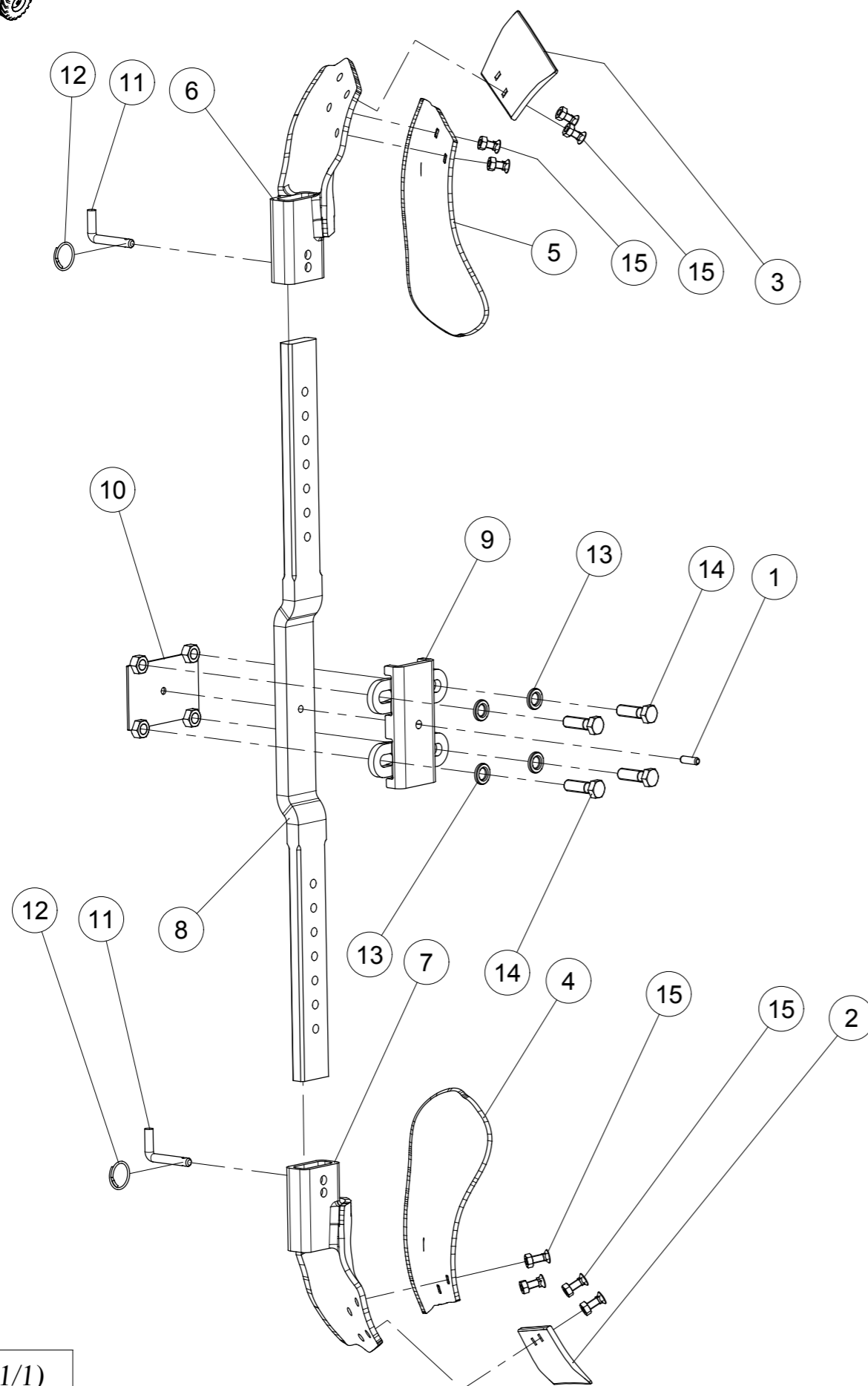

Repere	Quantite	Reference	Designation
1	1	1481D1030A	Goupille elastique 10 X 30 ISO8752 Z SPANNSTIFT 10 X 30 ISO8752 VERZ.
2	1	2715.05.01	Soc de rasette, Drt Dungereinlegershar SDG-18 B Verg.
3	1	2715.05.02	Soc de rasette, Gche Dungereinlegershar SDG-18 BL Verg.
4	1	2715.07.01	Versoir de rasette, Drt DUENGEREINL.STREICHBLECH RDG-21
5	1	2715.07.02	Versoir de rasette, Gche DUENGEREINL.STREICHBLECH RDG-21 L
6	1	2754.29.01	Pied soudé droit Vari Fix Brust Vari Fix Re. Verg. geschw. (26 Grad)
7	1	2754.29.02	Pied soudé gauche Vari Fix Brust Vari Fix Li. Verg: Geschw. (26 Grad)
8	1	2754.30.01	Montant de rasette Drehflugstiel RH 750/800
9	1	2754.32.02	Plaque d'assemblage Befestigungsplatte
10	1	2754.39.01	Plat de serrage Sicherungsblech Geschw.
11	2	6241.29.02	Axe TB-12x50 Steckstock TB-12x50
12	2	6608.12.07	Circlip Sicherungsring
13	4	6916D17A	Rondelle 17 EN14399-6 Z SCHEIBE 17 EN14399-6 Z
14	4	960D161550NA	Vis hex. M16x1.5x50 ZNBL 6KTS M16x1.5x50 Verzinkt
15	8	VI 13 14	Vis tête noyee 608-8.8 ZNBL M10x25+MU SENKCHR.608-8.8 Z M10x25+MU

Console avec roue
Konsole mit Radhalter + Rad

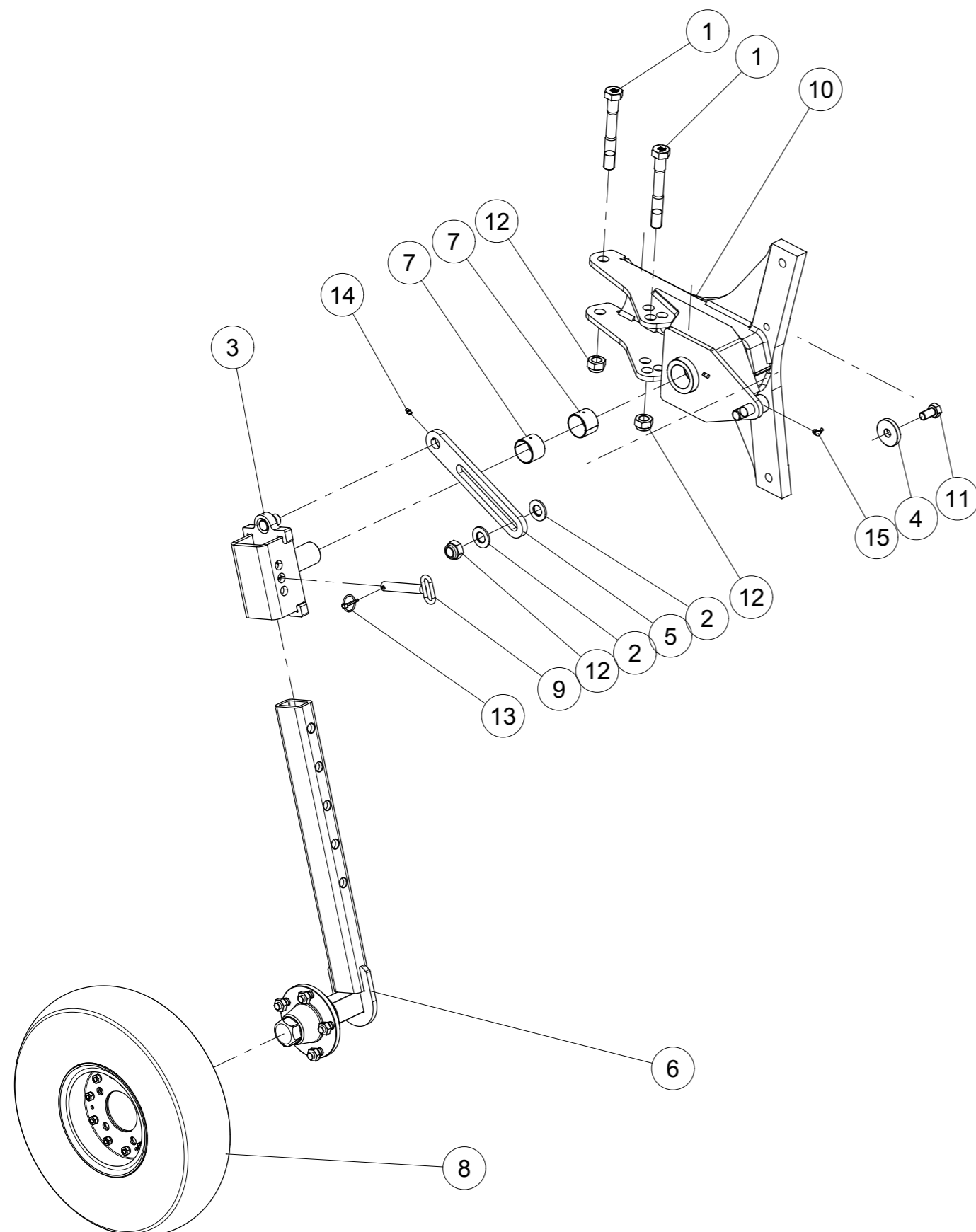

Repere	Quantite	Reference	Designation
1	2	1 118 356	Vis H M24x180 - 10.9 ZNBL, filet /36 mm Schraube H M24x180 - 10.9 ZNBL, Gewinde /36 mm
2	2	1 123 406	Rondelle Ertalon Dia 24x48 ep4 Scheibe Ertalon D. 24x48 Starke 4
3	1	1 123 410	Support age - roue Radflansch
4	1	1 123 411	Rondelle de roue Radscheibe
5	1	1 123 412	Glissiere - butee Roue Führung (Tiefeneinstellung)
6	1	1 123 413	Montant de roue Ar. Radarm
7	2	122 246	Bague bronze - Dia50x55, lg. : 40 mm Bronze-buchse - Dia50x55, lg. : 40 mm
8	1	198 710	Roue complete - 600 x 9, 5 trous Komplettrad 600x9 5-Loch
9	1	198 808	Broche de reglage Einstellbolzen
10	1	4814.00.24	Console avec support de roue Konsole mit Rad Halter
11	1	VI 44 02	Vis H M18x 35 - 8.8 ZNBL Schraube TH M18x 35 - 8.8 ZNBL
12	3	VJ 331	Ecrou frein std H M 24 - 8 ZNBL Stopfmutter std H M 24 - 8 ZNBL
13	1	VL 101	Goupille "Clips" Dia6 Z Klappsplint "Clips" Dia6 Z
14	1	VM 201	Graisser droit - M8, pas125 Gerader Schmiernippel - M8 x 125
15	1	VM 203	Graisser coude 90° M8x125 Schmiernippel 90° - M8x125

4814.00.23 (1/1)



RABE

ZI Nord Les Gaudères
37130 Langeais

France - Frankreich

Tel. (+33) 2 47 96 72 61
Fax (+33) 2 47 96 71 85
info@rabe-gb.fr
www.rabe-gb.fr

RABE

Am Rabewerk 1
49152 Bad Essen

Allemagne - Deutschland

Tel. +49 (0) 54 72 771 - 0
Fax +49 (0) 54 72 771 -195
info@rabe-gb.de
www.rabe-gb.de