

		/				
--	--	---	--	--	--	--



**RABE**



## Important pour la commande de pièces de rechange

Lors de chaque commande de pièces, veuillez nous communiquer les données suivantes:

1. Type de la machine (gravé sur la plaque d'identification).
2. Numéro de série de la machine (gravé sur la Plaque d'identification et le bâti).
3. Numéro de pièce.
4. La quantité nécessaire de pièces de rechange.

## Important for ordering spare parts

Please give the following information whenever you order spare parts:

1. Type of the machine (stamped on type plate)
2. Serial number (stamped on type plate and frame)
3. Part number.
4. The required quantity of the spare parts.

### Plaquette / Identification plate





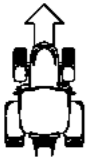

*Machine 3,10m - 10 dents - Pas 306*  
*Machine 3,10m - 10 tines - Spacing 306*

<i>Index</i>	<i>Quantite</i>	<i>Reference</i>	<i>Designation</i>
1	10	26850	DENT PARALIFT RESSORT PARALIFT TINE - SPRING
-	-	26115	DENT PARALIFT - BOULON PARALIFT TINE - SHEAR BOLT

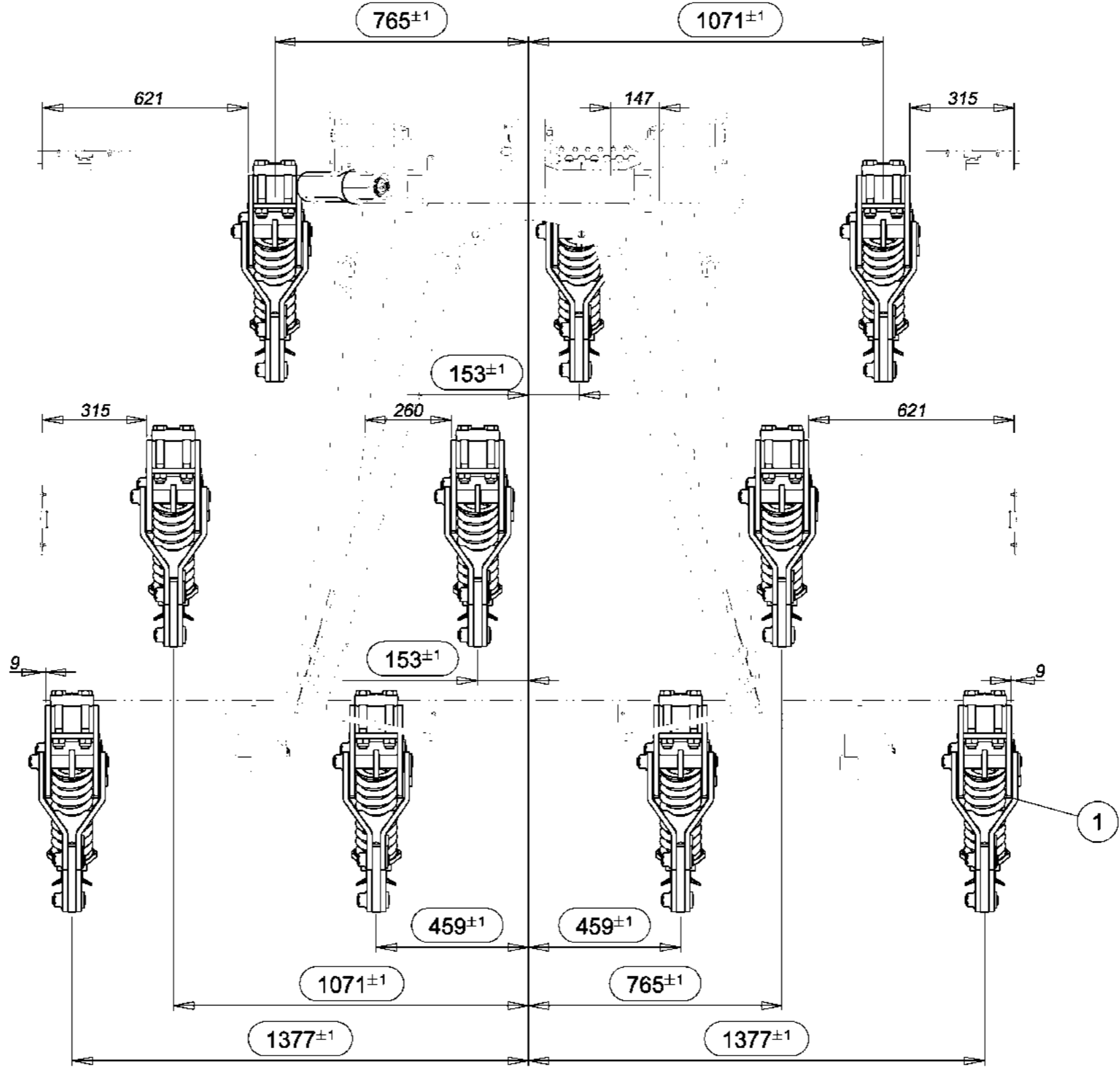



**DENT PARALIFT RESSORT**  
**PARALIFT TINE - SPRING**

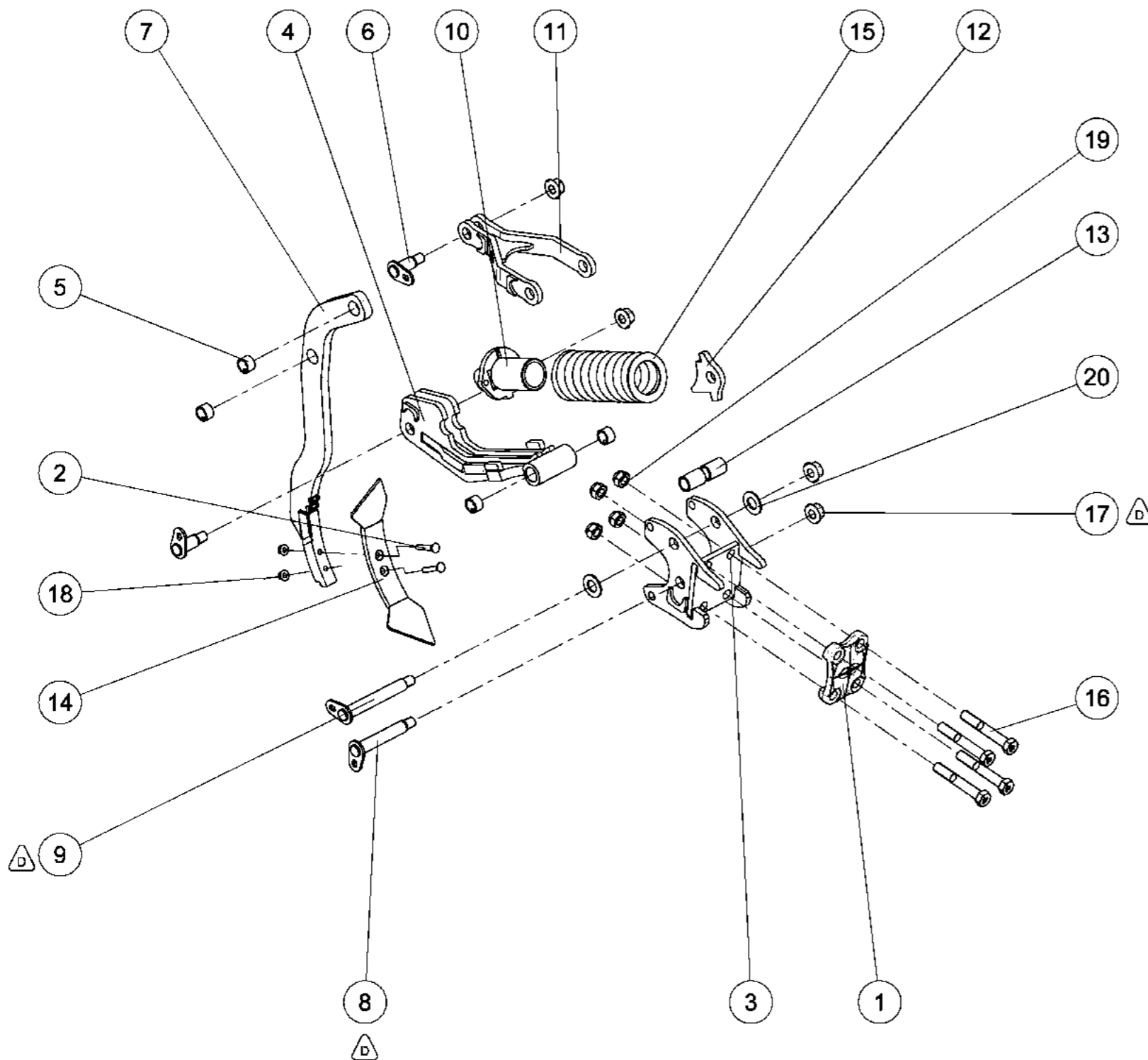

Index	Quantite	Reference	Designation
1	1	6 920 138	Contre plaque Eurochisel M24 M24 Eurochisel counter-plate
2	2	11 189	Vis TFCC M12x 70 - 12.9 ZNBL DIN608 Screw TFCC M12x 70 - 12.9 ZNBL DIN608
3	1	26851	BOITIER
4	1	26853	BIELLE INFERIEURE
5	4	26886	Bagues acier Ø 38 x 30 x 25 Steel bushing Ø 38 x 30 x 25
6	2	26888	AXE Ø30 Lt96 Lst85
7	1	26890	ETANCON SOUDE --
8	1	26892	AXE Ø30 Lt201 Lst190
9	1	26894	AXE Ø30 Lt241 Lst230
10	1	26899	SOUS ENSEMBLE PIVOT + GUIDAGE RESSORT
11	1	26905	BIELLE SUPERIEURE
12	1	26915	PIECE D'ORIENTATION RESSORT Spring positioning part
13	2	26916	DOUILLE SOCKET
14	1	6331.04.02	--
15	1	M670014	Ressort comp Dia 127x82.5x407 fil Dia 20 Compression spring Ø127 x 82.5 x 407 cord Ø20
16	4	VI 35 12	Vis H M24x160 - 8.8 ZNBL DIN931 Screw H M24x160 - 8.8 ZNBL DIN931
17	4	VJ 147	Ecrou HEFR M24 emb. S.Lock Cl.10 ZNBL DIN6927 HEFR M24 Flg nut Gr.10 ZNBL DIN6927
18	2	VJ 157	Ecrou HEFR M12 emb. S.Lock Cl.10 ZNBL DIN6927 HEFR M12 Flg nut Gr.10 ZNBL DIN6927
19	4	VJ 331	Ecrou frein std H M 24 - 8 ZNBL DIN985 Nyloc nut std H M 24 - 8 ZNBL DIN985
20	2	VK 513	Rondelle plate MU30 ZNBL NFE25513 Flat washer MU30 ZNBL NFE25513



**DENT SECURITE BOULON - 800mm**  
**SHEAR BOLT TINE - 800mm**

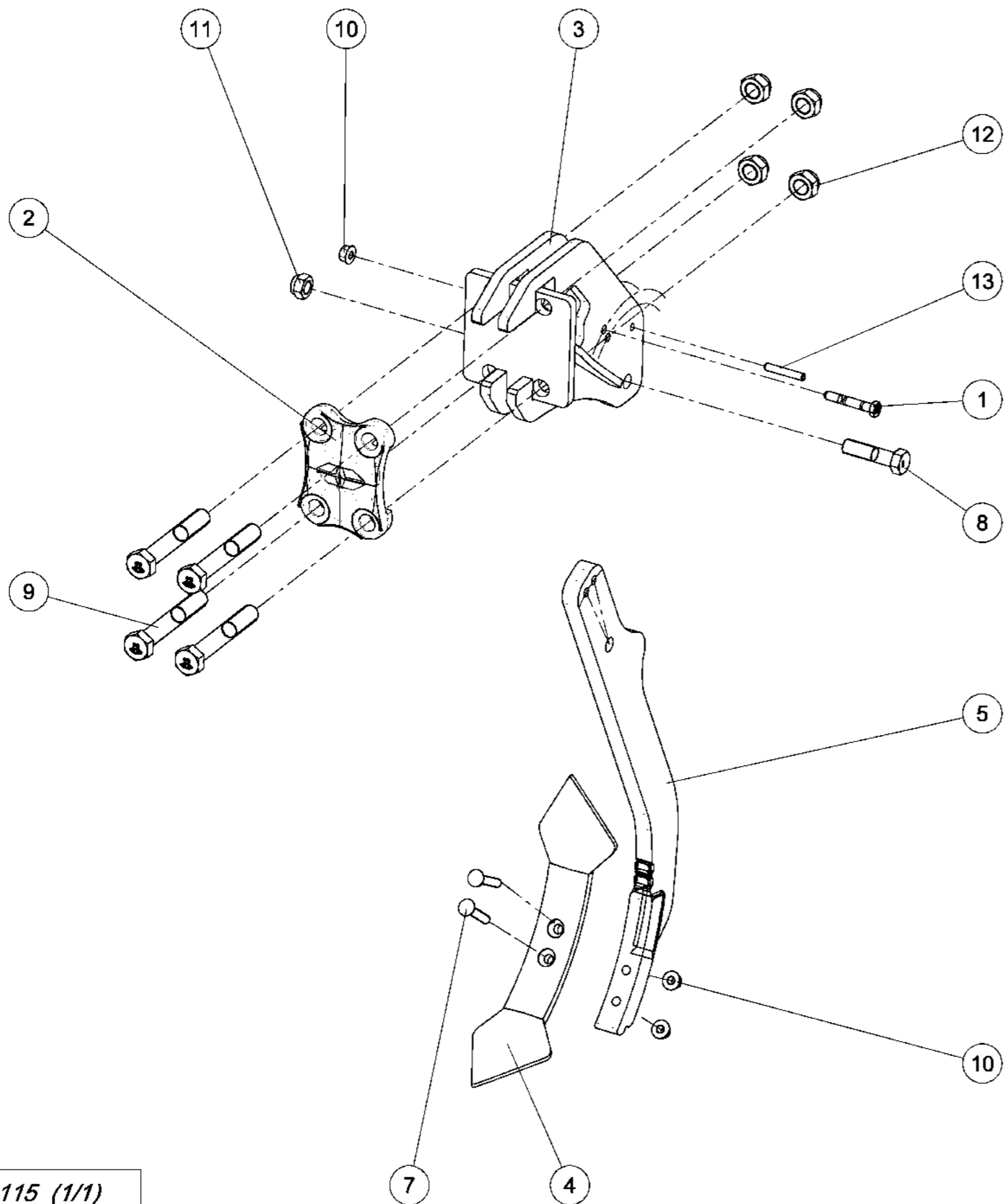

Index	Quantite	Reference	Designation
1	1	6 433 170	Vis HM12x75 rainurée 12.9 Screw HM12x75 10.9 grooved 12.9
2	1	6 920 138	Contre plaque Eurochisel M24 M24 Eurochisel counter-plate
3	1	26110	BOITIER SECURITE BOULON
4	1	6331.04.02	--
5	1	26848	ETANCON SOUDE - 800mm --
-	-	26846	ETANCON SOUDE - 700mm LEG - 700mm
7	2	SP 11 189	Vis TFCC M12x 70 - 12.9 Brut Screw TFCC M12x 70 - 12.9 Black
8	1	VI 33 07	Vis H M20x 80 - 8.8 ZNBL DIN931 Screw H M20x 80 - 8.8 ZNBL DIN931
9	4	VI 35 12	Vis H M24x160 - 8.8 ZNBL DIN931 Screw H M24x160 - 8.8 ZNBL DIN931
10	3	VJ 157	Ecrou HEFR M12 emb. S.Lock Cl.10 ZNBL DIN6927 HEFR M12 Flg nut Gr.10 ZNBL DIN6927
11	1	VJ 327	Ecrou frein std H M 20 - 8 ZNBL DIN985 Nyloc nut std H M 20 - 8 ZNBL DIN985
12	4	VJ 331	Ecrou frein std H M 24 - 8 ZNBL DIN985 Nyloc nut std H M 24 - 8 ZNBL DIN985
13	1	VL 225	Goupille elastique epaisse - 10x60 mm, ZNBL Thick roll pin - 10x60 mm, ZNBL



*Machine 3,10m - 10 dents - Pas 306*  
*Machine 3,10m - 10 tines - Spacing 306*

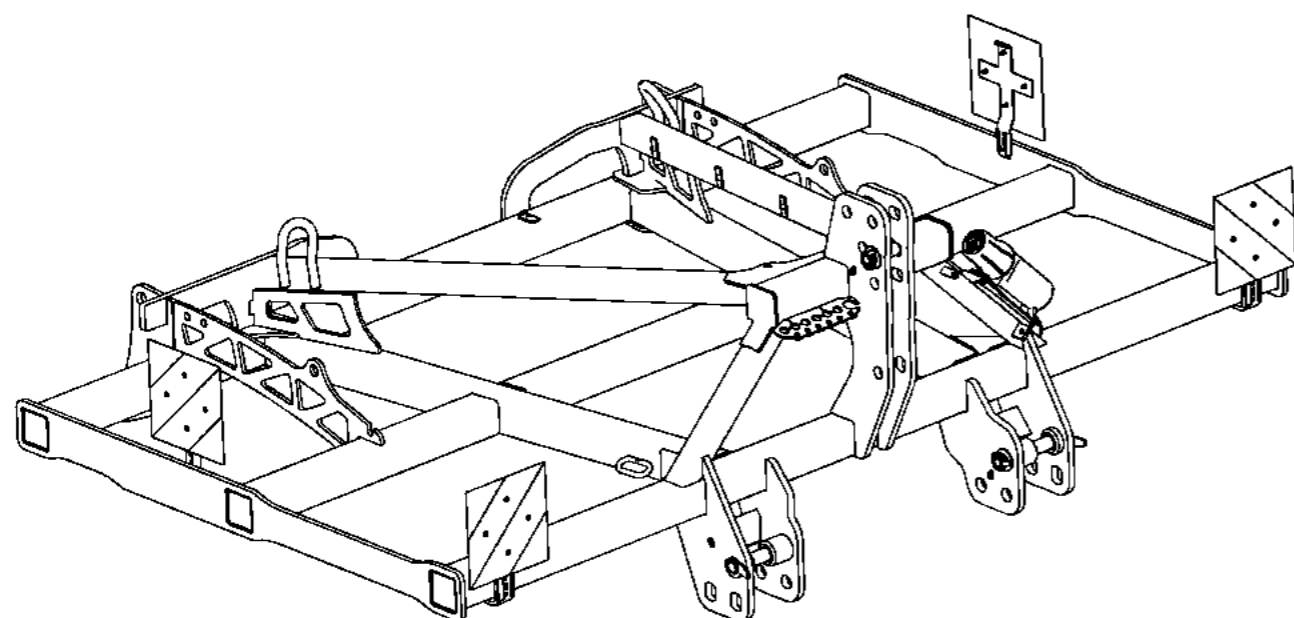

<i>Index</i>	<i>Quantité</i>	<i>Reference</i>	<i>Designation</i>
1	1	6 432 860	Broche attelage 3 point montée 3 point linkage pin
2	2	6 432 862	Broche att. Inf. CAT III N & III monté Inferior hitch pin CAT III N & III
3	1	6 432 863	Goupille clips DIN 10x45 + chaîne 20 maillons Clips pin DIN 10 x 45 + chain 20 links
4	2	6 432 864	Goupille Clips DIN 10x45 + chaîne 8 maillons Clips pin DIN 10x45 + chain 8 links
5	1	6 433 158	Chassis3m pas 306 frame 3m - 306 spacing
6	2	7 017 782	Ensemble réfléch. clas.B 282x282 VG Reflective kit classe B 282x282 VG
7	2	7 017 784	Ensemble réfléch. clas.B 282x282 VD Reflective kit classe B 282x282 VD
8	2	6258.13.15	Douille d'attelage Lg:70mm Hitch spacer length 70mm
9	2	6258.13.16	Douille d'attelage Lg:25mm Hitch spacer length 25mm
10	3	VI 27 04	Vis H M8x 20 - 8.8 ZNBL Screw H M8x 20 - 8.8 ZNBL
11	3	VJ 320	Ecrou frein std H M 8 - 8 ZNBL Nyloc nut std H M 8 - 8 ZNBL
12	3	VK 502	Rondelle plate MU8 ZNBL Flat washer MU8 ZNBL
13	3	VK 513	Rondelle plate MU30 ZNBL Flat washer MU30 ZNBL
14	1	WH 149	Tube porte documents Documents support tube



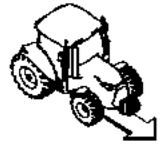

*Machine 3,10m - 10 dents - Pas 306*  
*Machine 3,10m - 10 tines - Spacing 306*

Index	Quantite	Reference	Designation
1	1	6 432 860	Broche attelage 3 point montée 3 point linkage pin
2	2	6 432 862	Broche att. Inf. CAT III N & III monté Inferior hitch pin CAT III N & III
3	1	6 432 863	Goupille clips DIN 10x45 + chaine 20 maillons Clips pin DIN 10 x 45 + chain 20 links
4	2	6 432 864	Goupille Clips DIN 10x45 + chaine 8 maillons Clips pin DIN 10x45 + chain 8 links
5	1	6 433 158	Chassis3m pas 306 frame 3m - 306 spacing
6	2	6258.13.15	Douille d'attelage Lg:70mm Hitch spacer length 70mm
7	2	6258.13.16	Douille d'attelage Lg:25mm Hitch spacer length 25mm
8	3	VK 513	Rondelle plate MU30 ZNBL Flat washer MU30 ZNBL

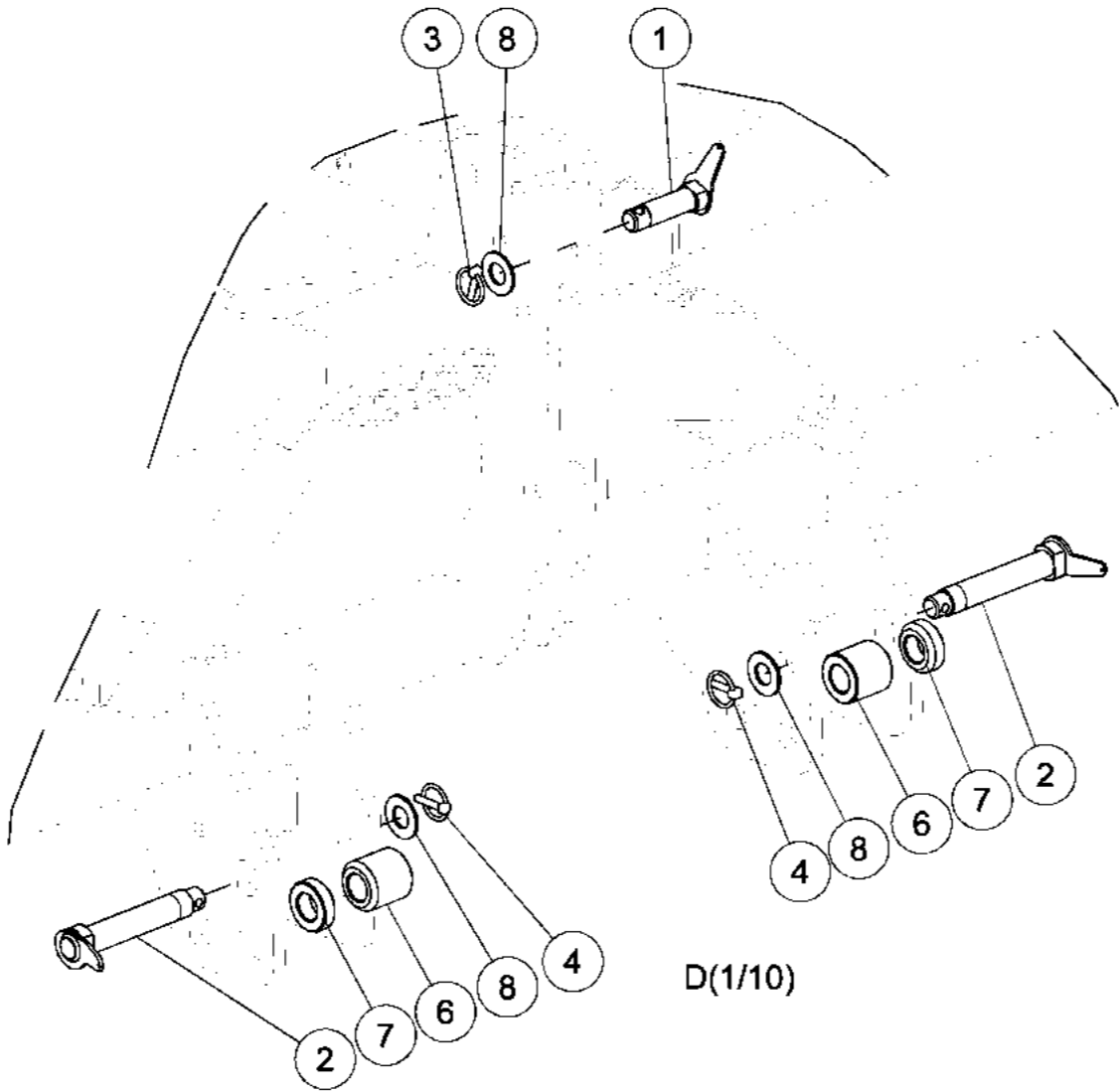
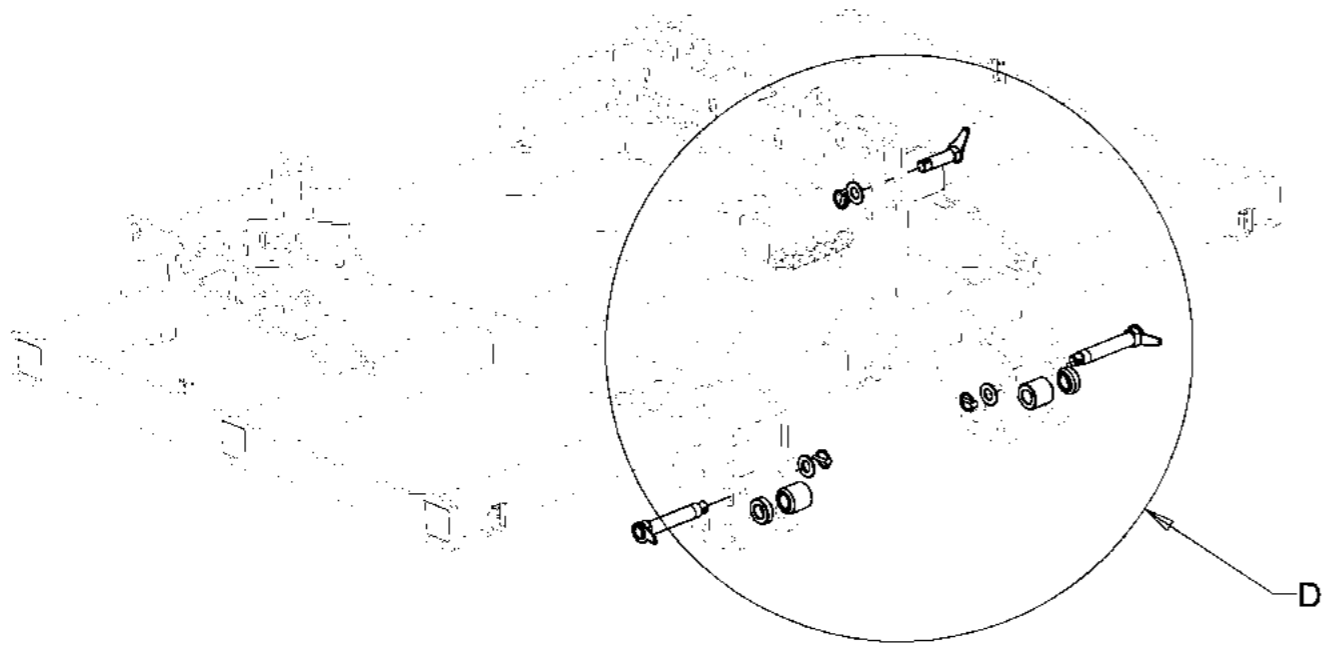



*Machine 3,10m - 10 dents - Pas 306*  
*Machine 3,10m - 10 tines - Spacing 306*

Index	Quantite	Reference	Designation
1	2	7 017 782	Ensemble réfléch. clas.B 282x282 VG Reflective kit classe B 282x282 VG
2	2	7 017 784	Ensemble réfléch. clas.B 282x282 VD Reflective kit classe B 282x282 VD
3	3	VI 27 04	Vis H M8x 20 - 8.8 ZNBL Screw H M8x 20 - 8.8 ZNBL
4	3	VJ 320	Écrou frein std H M 8 - 8 ZNBL Nyloc nut std H M 8 - 8 ZNBL
5	3	VK 502	Rondelle plate MU8 ZNBL Flat washer MU8 ZNBL
6	1	WH 149	Tube porte documents Documents support tube

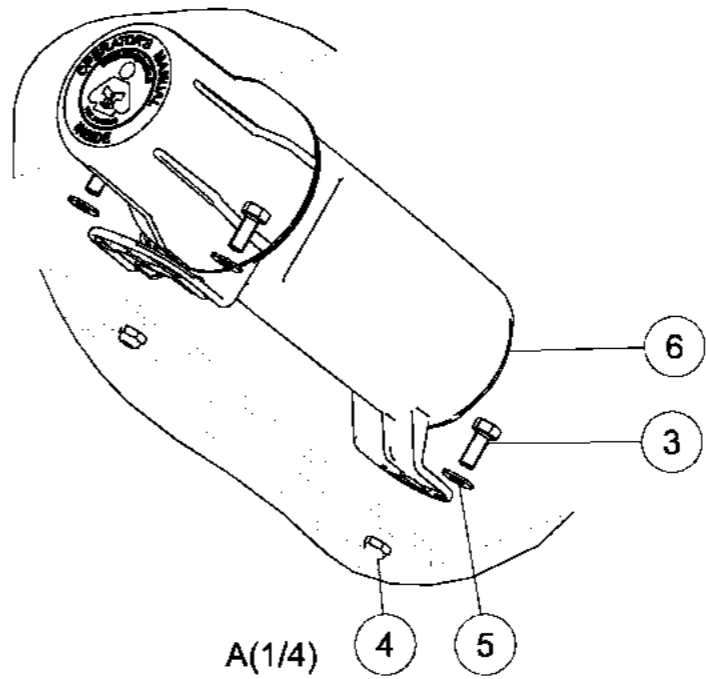
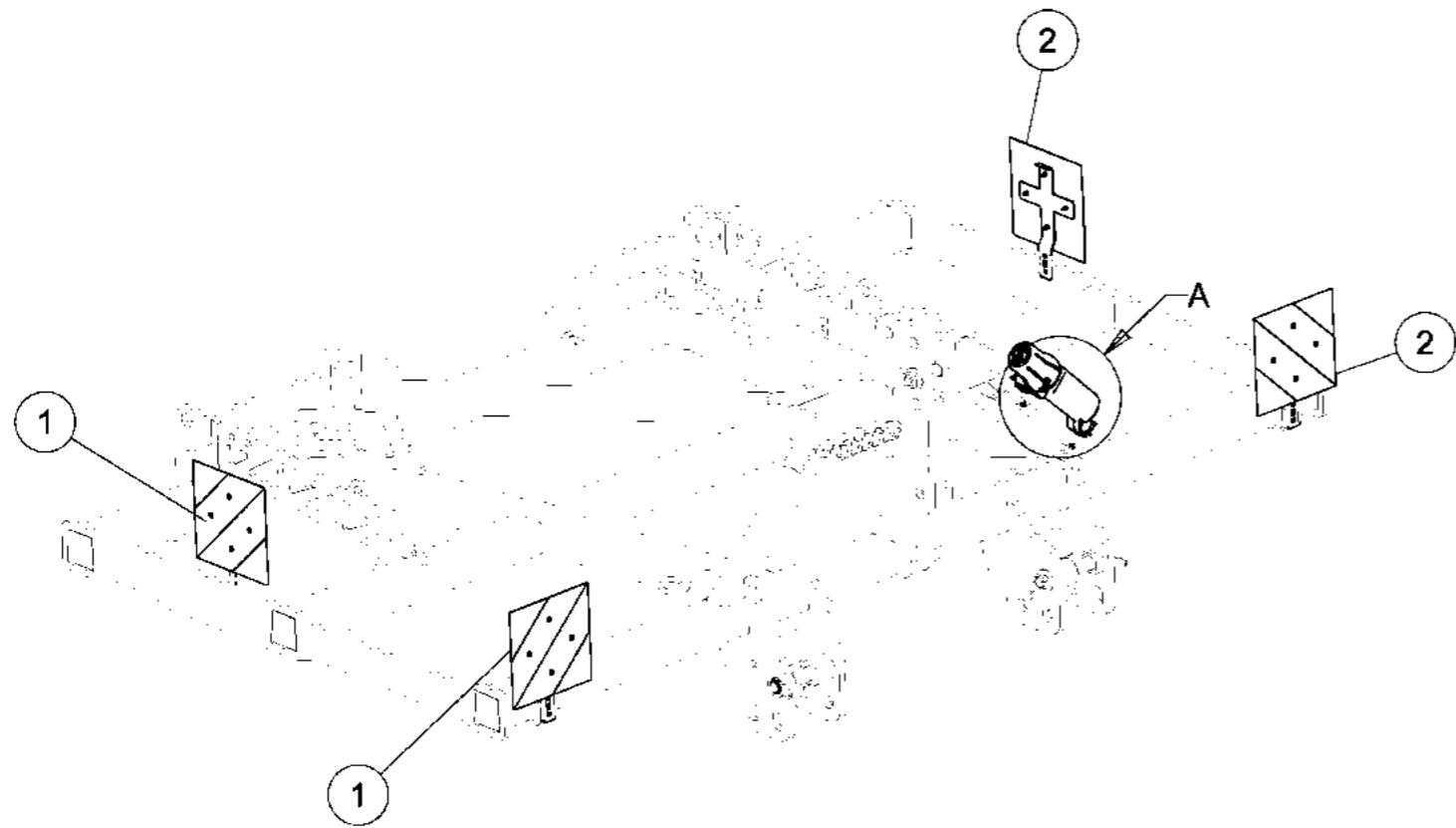

*Broche attelage 3 point montée*  
*3 point linkage pin*

<i>Index</i>	<i>Quantite</i>	<i>Reference</i>	<i>Designation</i>
1	1	1 122 873	Broche d'attelage 3em point Top link pin
2	1	6 432 861	Chaine longue 20 maillons + anneaux 20 link chain + ring

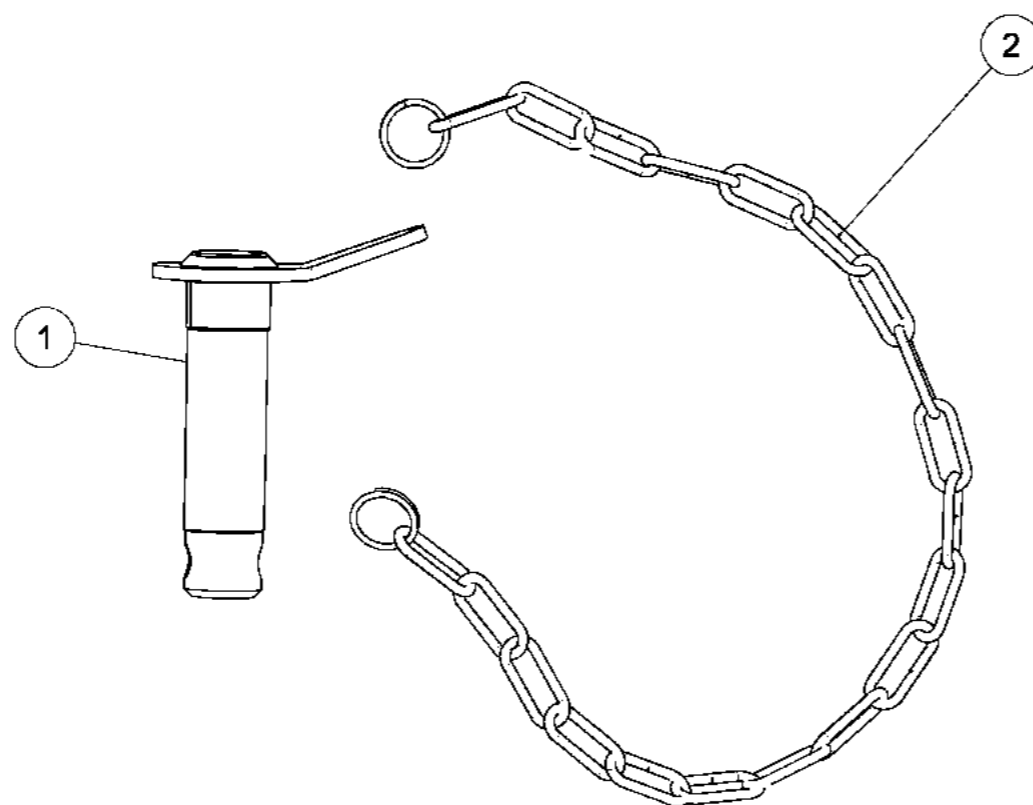

*Broche att. Inf. CAT III N & III monté*  
*Inferior hitch pin CAT III N & III*

<i>Index</i>	<i>Quantite</i>	<i>Reference</i>	<i>Designation</i>
1	1	6 432 861	Chaine longue 20 maillons + anneaux 20 link chain + ring
2	1	6 640 222	Broche d'attelage inf cat. III N & III Lower link pin cat. III N et III

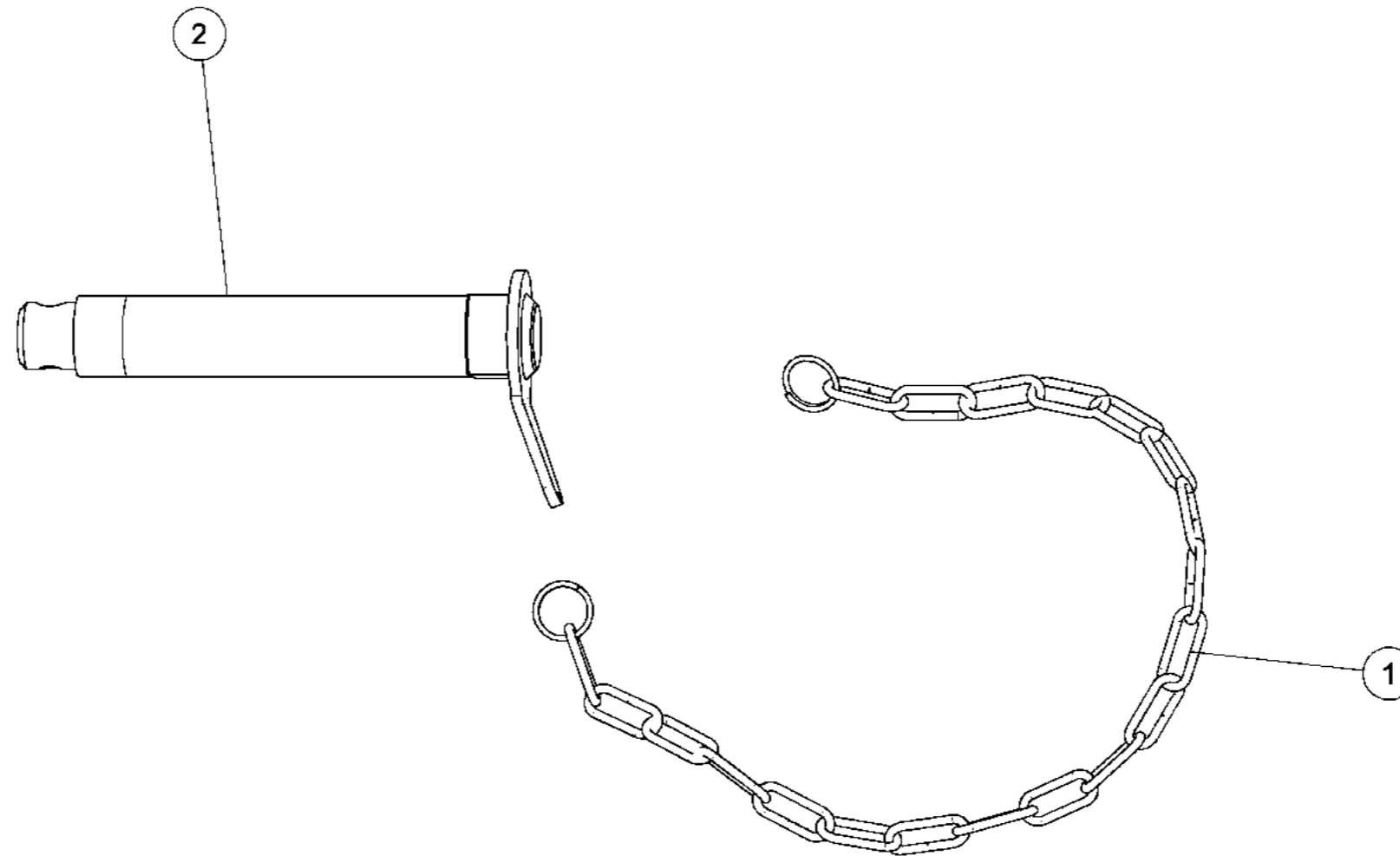

*Goupille clips DIN 10x45 + chaine 20 maillons*

*Clips pin DIN 10 x 45 + chain 20 links*

<i>Index</i>	<i>Quantite</i>	<i>Reference</i>	<i>Designation</i>
1	1	6 432 861	Chaine longue 20 maillons + anneaux 20 link chain + ring
2	1	VL 105	Goupille "Clips-surete" Dia10 Z Lynch pin "Clips-surete" Dia10 Z

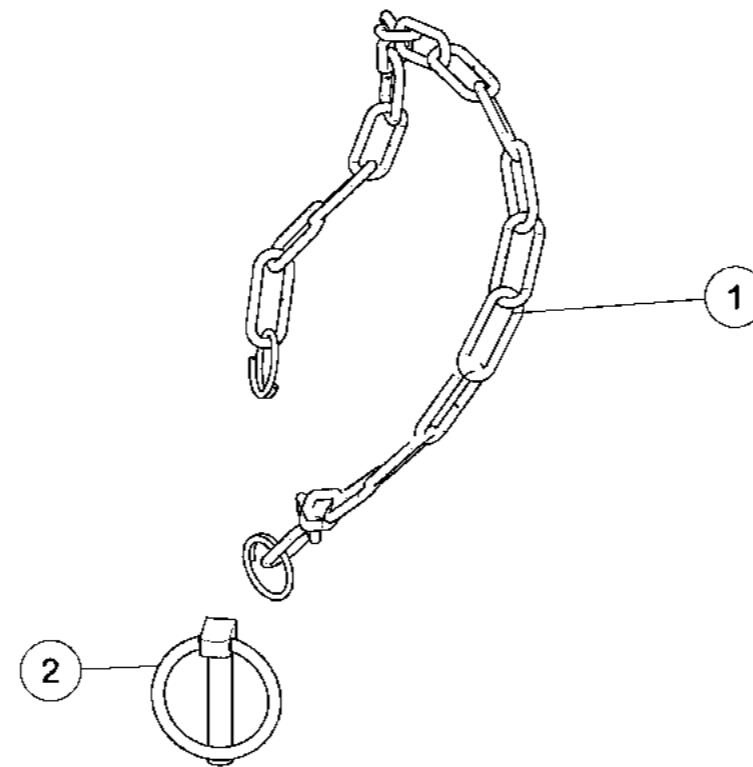

*Goupille Clips DIN 10x45 + chaine 8 maillons**Clips pin DIN 10x45 + chain 8 links*

<i>Index</i>	<i>Quantite</i>	<i>Reference</i>	<i>Designation</i>
1	1	6 432 865	Chaine courte 8 maillons + anneaux 8 link chain + ring
2	1	VL 105	Goupille "Clips-surete" Dia10 Z Lynch pin "Clips-surete" Dia10 Z

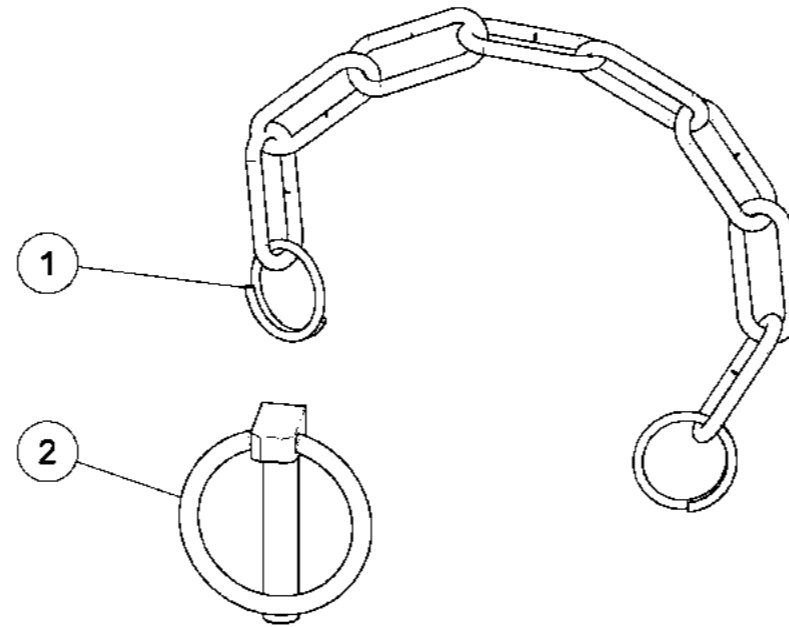

*Ensemble réfléchissant 282x282 VG*

*Reflective kit 282x282 LV*

<i>Index</i>	<i>Quantité</i>	<i>Reference</i>	<i>Designation</i>
1	1	1 221 243	Support plaque réfléchissante Reflective plate support
2	1	7 018 300	Plaque réfléchissante DIN/TPESC Reflecting plate DIN/TPESC
3	4	VI 15 31	Vis TBF "Poelier" M6x16 Screw TBF "Poelier" M6x16
4	4	VJ 340	Écrou frein std H M 6 - 8 ZNBL Nyloc nut std H M 6 - 8 ZNBL

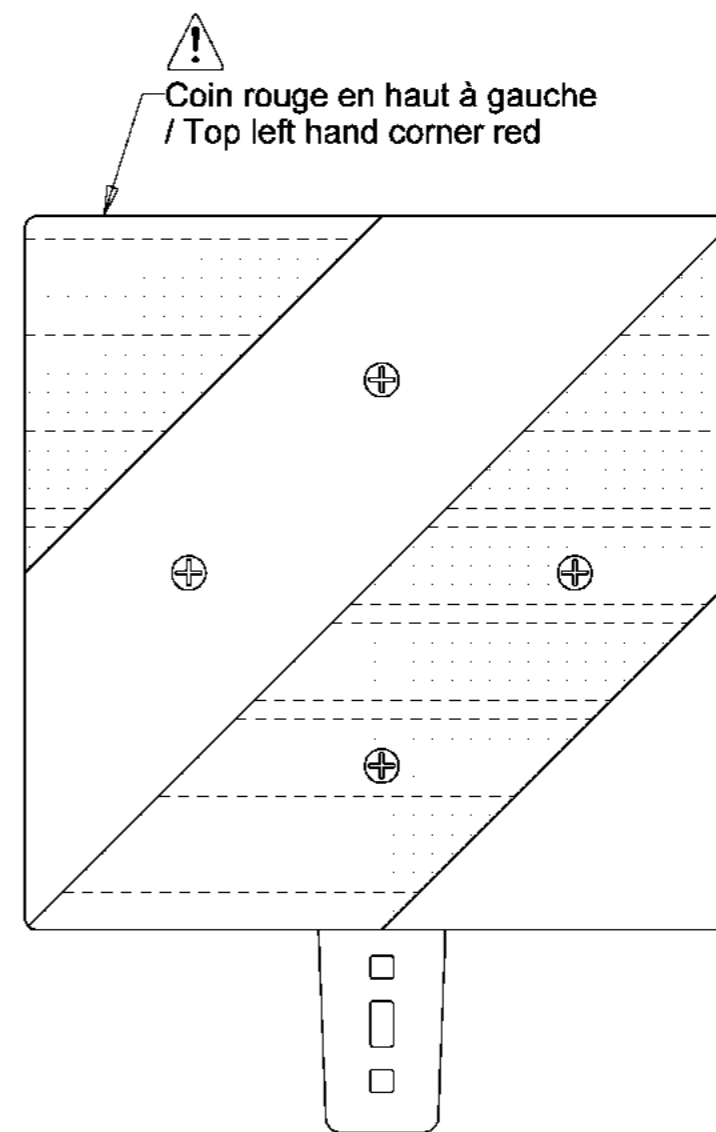
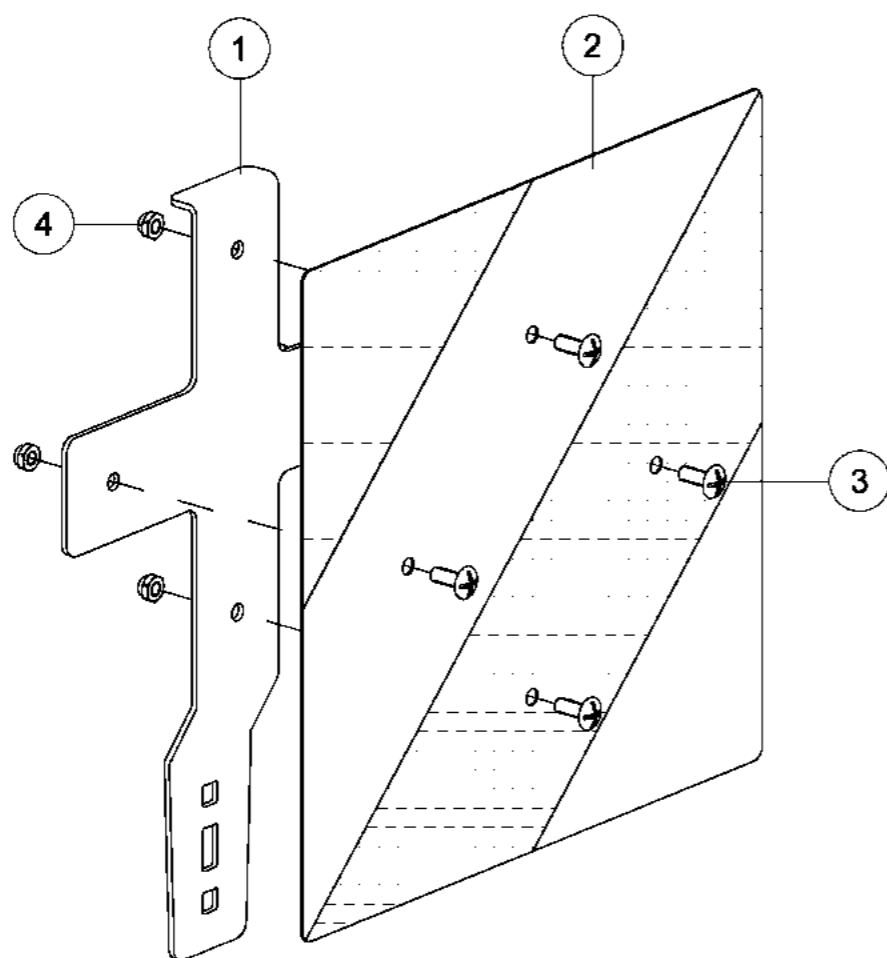

*Ensemble réfléchissant 282x282 VD*  
*Reflective kit 282x282 RV*

<i>Index</i>	<i>Quantité</i>	<i>Reference</i>	<i>Designation</i>
1	1	1 221 243	Support plaque réfléchissante Reflective plate support
2	1	7 018 300	Plaque réfléchissante DIN/TPESC Reflecting plate DIN/TPESC
3	4	VI 15 31	Vis TBF "Poelier" M6x16 Screw TBF "Poelier" M6x16
4	4	VJ 340	Écrou frein std H M 6 - 8 ZNBL Nyloc nut std H M 6 - 8 ZNBL

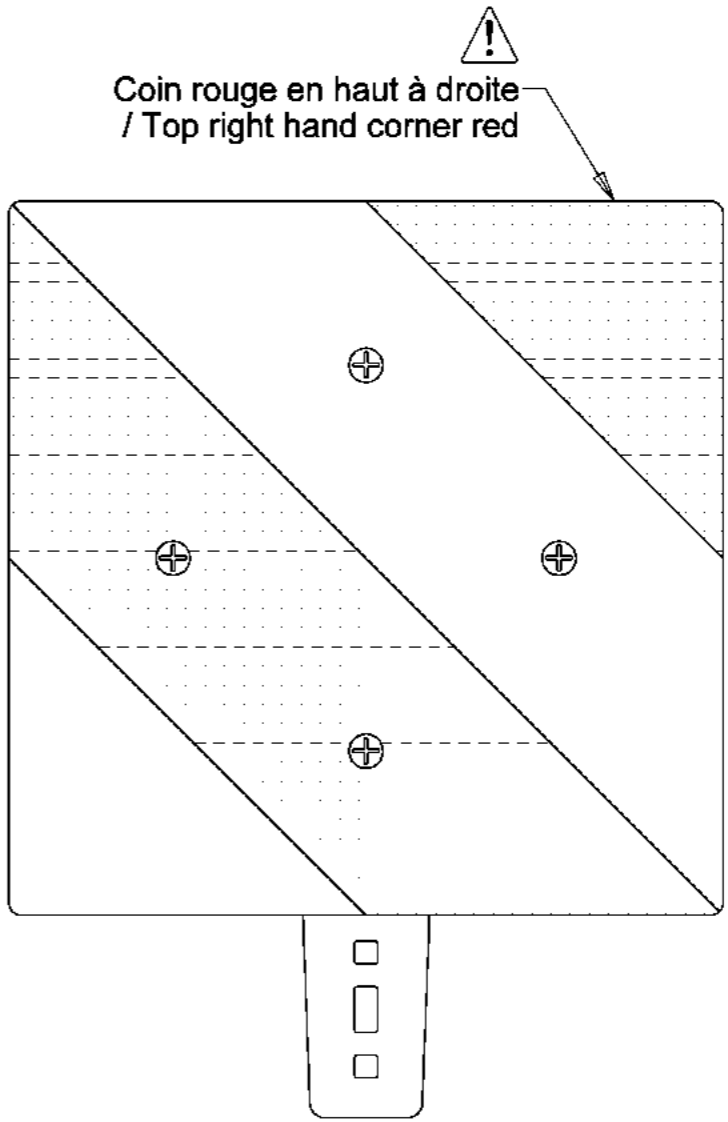
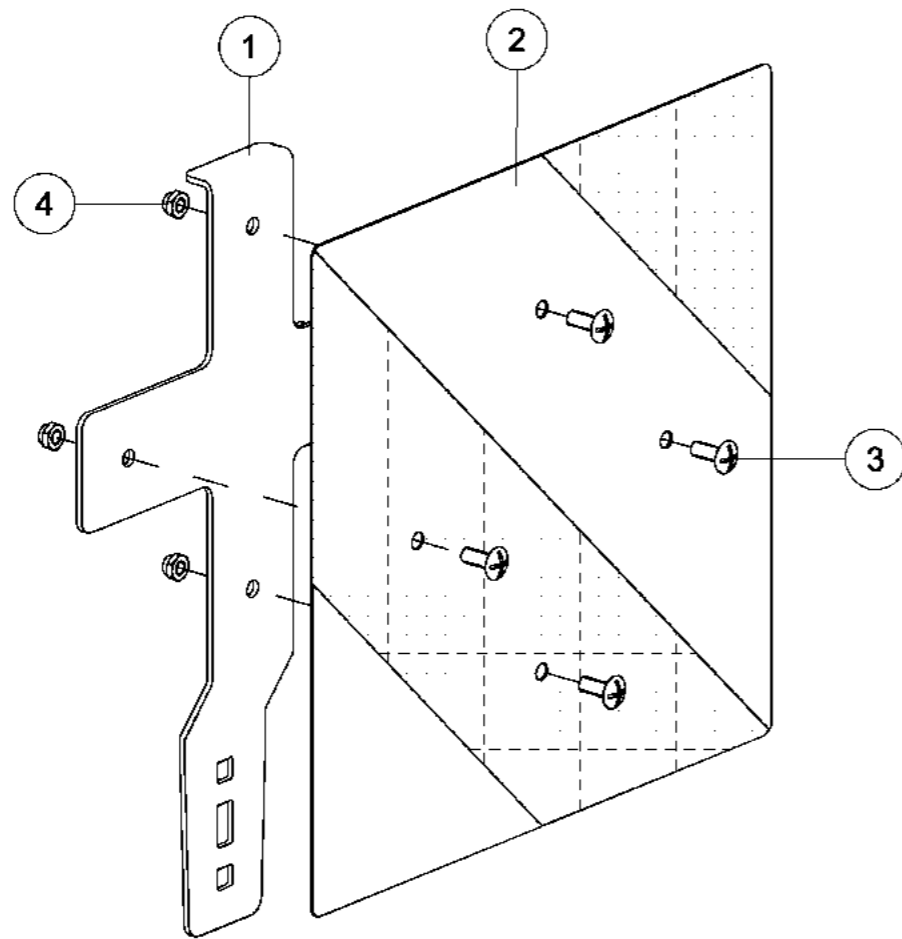





*Kit d'éclairage sans acces. 3.0m P.*

*Lighting kit without acces. 3.0m M.*

Index	Quantite	Reference	Designation
1	1	1 221 432-7500	Câble prise alu. 7P / connect. 6P Cable with plug 7W alu. / plug 6W
2	1	6 433 979	Rampe d'éclairage 3.0m VP. Lighting ramp 3.0m VM.
3	2	6 433 986	Support rampe d'éclairage Lighting ramp support
4	2	M 631 100	Etrier □40 - M10 Flange □40 - M10
5	2	M 631 181	Etrier M20 □100 aplati 10.9 Flange M20 □100 flattened 10.9
6	4	VJ 141	Ecrou HEFR M10 emb. S.Lock Cl.10 HEFR M10 Flg nut Gr.10 ZNBL
7	4	VJ 145	Ecrou HEFR M20 emb. S.Lock Cl.10 HEFR M20 Flg nut Gr.10 ZNBL

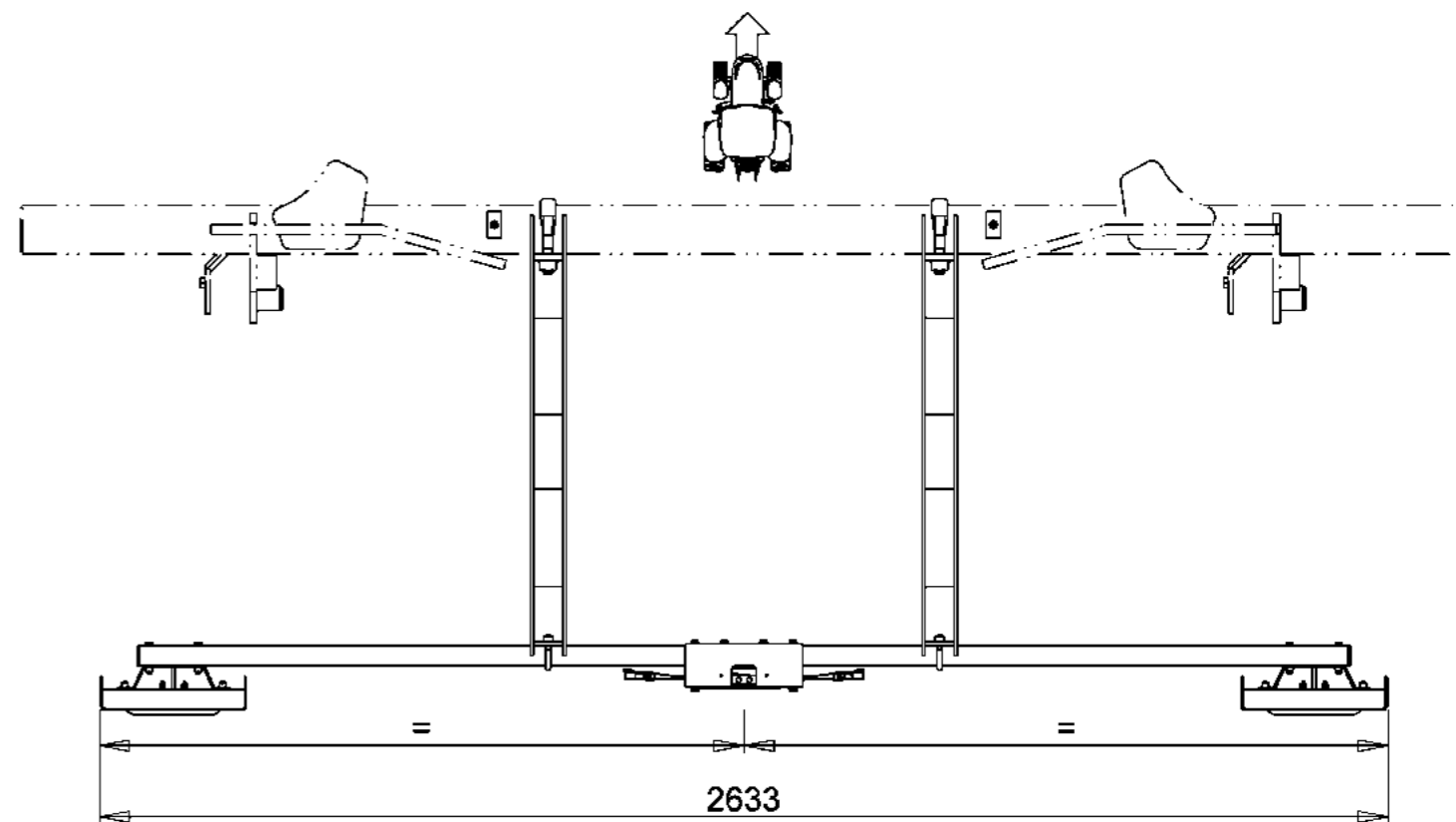
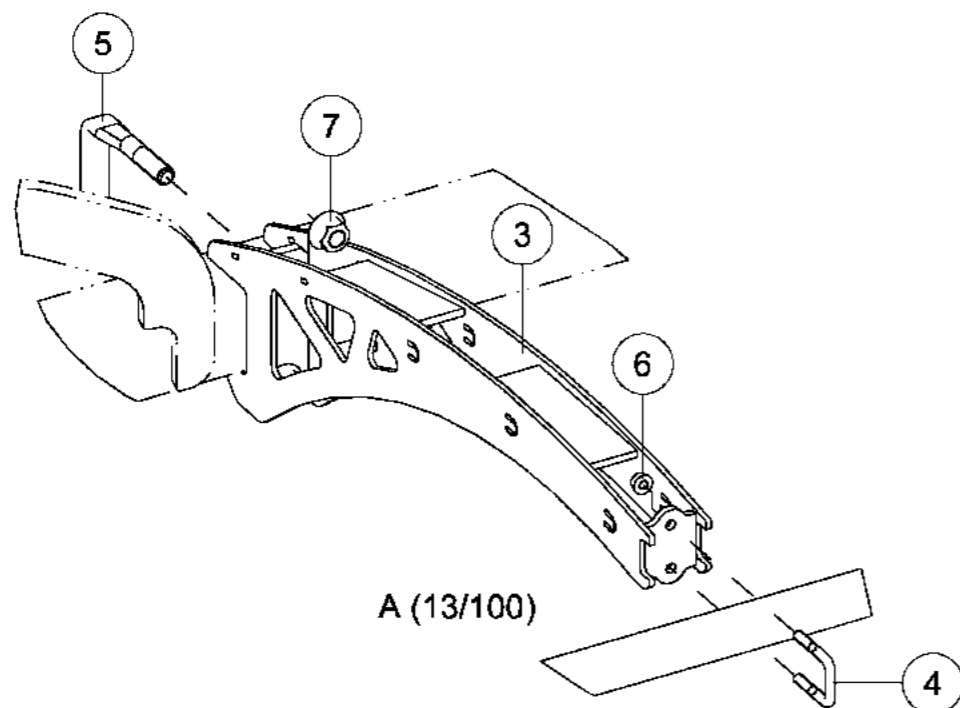
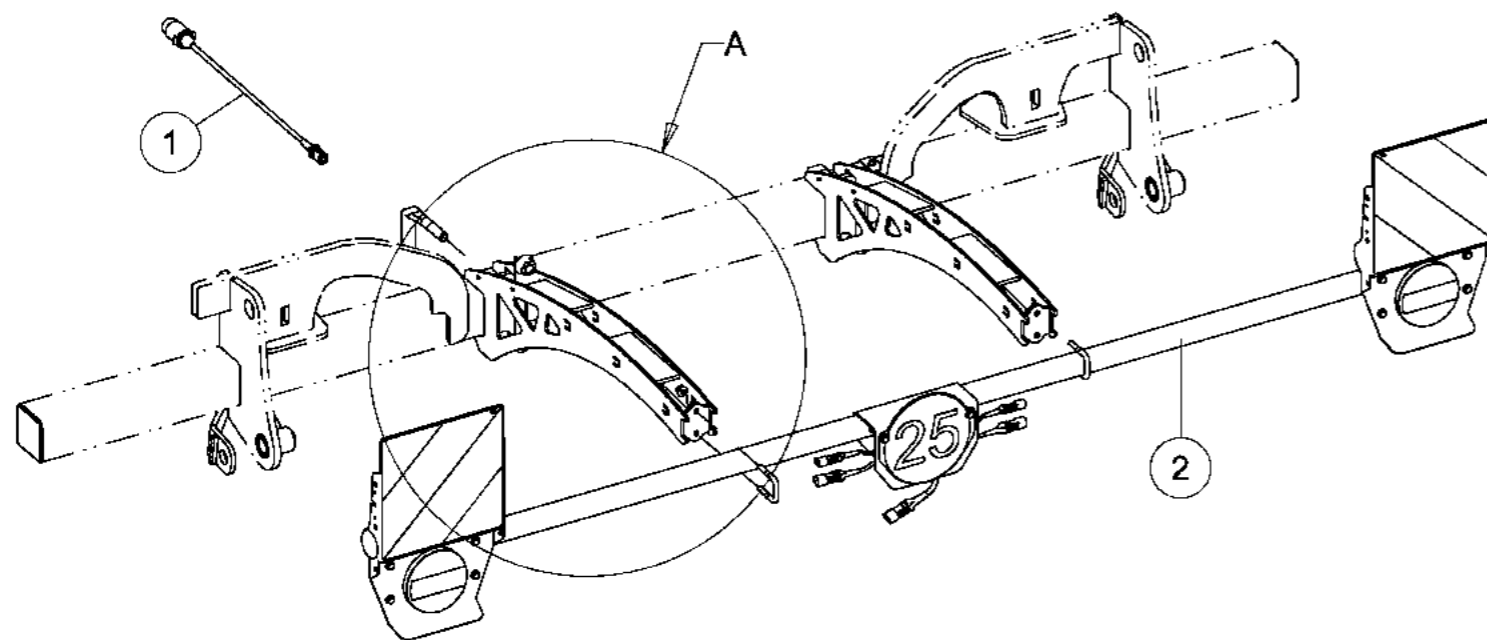

Rampe centrée par rapport à la machine  
/ Ramp centered in relation to the machine

Rampe d'éclairage 3.0m VP.

Lighting ramp 3.0m VM.

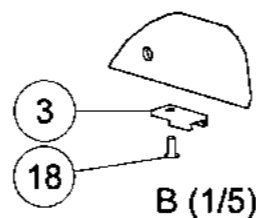
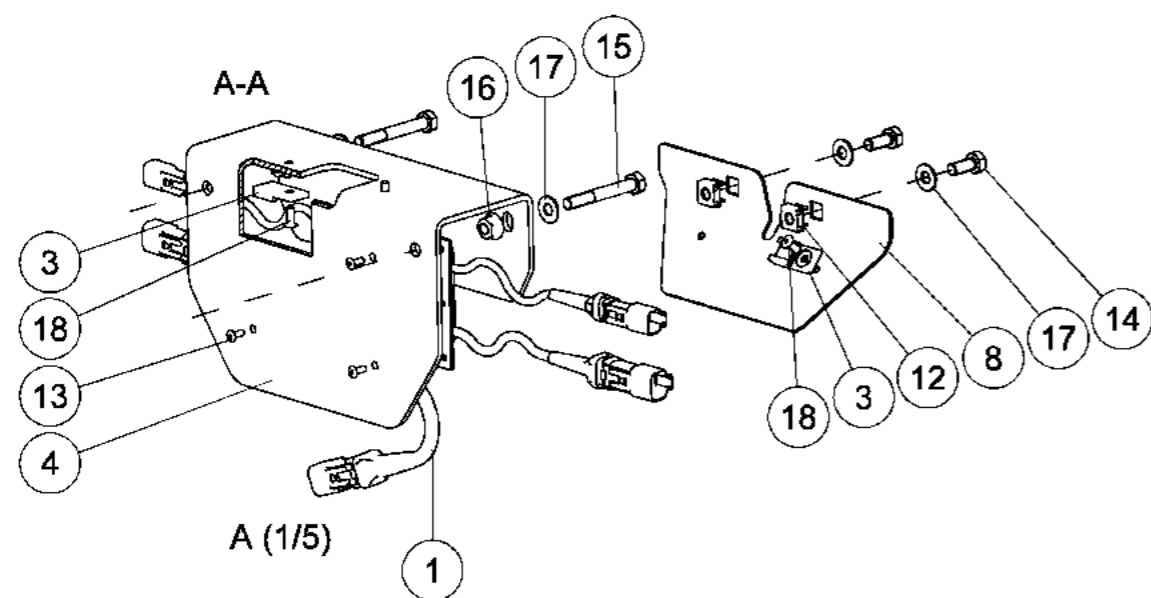
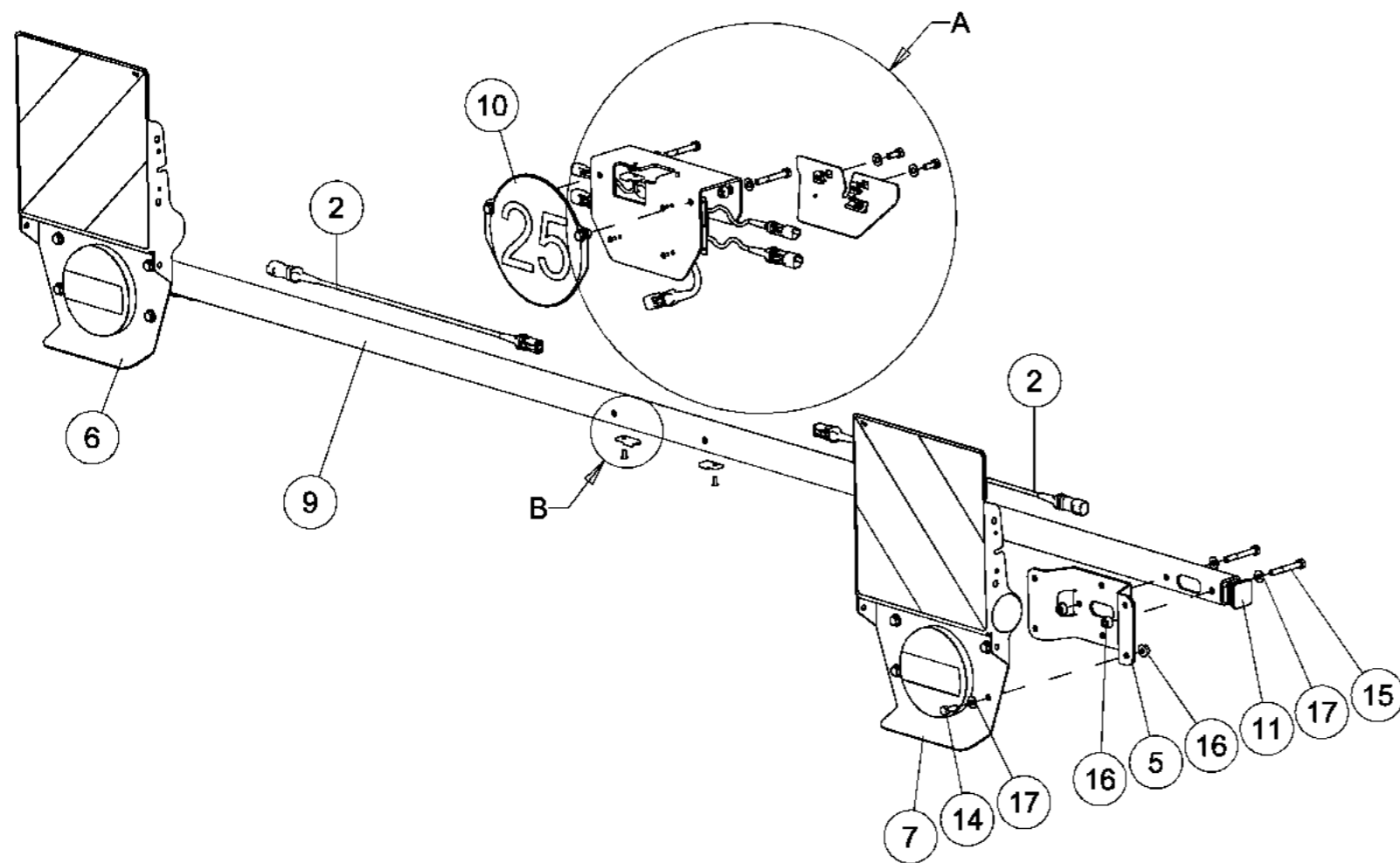

Index	Quantité	Reference	Designation
1	1	1 221 431	Boite de dérivation Distribution box
2	2	1 221 434-1250	Rallonge 4 Plots 4-Way extension
3	5	1 222 318	Clip de montage connect. femelle Mounting clip for pins
4	1	6 433 933	Support central boîtier de dériv. Distribution box central support
5	2	6 433 944	Support Support
6	1	6 433 945	Module d'éclairage VP Gch. Lighting unit VM LH
7	1	6 433 946	Module d'éclairage VP Drt. Lighting unit VM RH
8	1	6 433 963	Protection centrale Central protection
9	1	6 433 976	Tube rampe d'éclairage 3.0m Light ramp tube 3.0m
10	1	6 433 994	Module panneau 25km/h 25km/h sign unit
11	2	850 100 373	Bouchon plast. pour tube 40x40x4 Square plastic plugs LQ40x40x4
12	2	851 055 793	Ecrou à cage M8 Cage nut M8
13	4	7337D410AL	Rivet "Pop" 4.0x10 Rivet "Pop" alu Dia 4.0x10
14	10	VI 27 04	Vis H M8x 20 - 8.8 ZNBL Screw H M8x 20 - 8.8 ZNBL
15	6	VI 27 11	Vis H M8x 60 - 8.8 ZNBL Screw H M8x 60 - 8.8 ZNBL
16	14	VJ 140	Ecrou HEFR M8 emb. S.Lock Cl.10 HEFR M8 Flg nut Gr.10 ZNBL
17	16	VK 502	Rondelle plate MU8 ZNBL Flat washer MU8 ZNBL
18	5	VM 414	Rivet "Pop" 4.8x12 Rivet "Pop" alu Dia 4.8x12

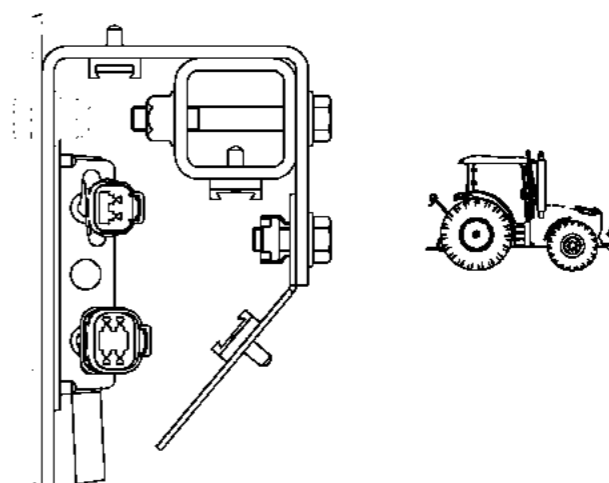



*Kit d'éclairage sans acces. 3.5m P.*

*Lighting kit without acces. 3.5m M.*

Index	Quantite	Reference	Designation
1	1	1 221 432-7500	Câble prise alu. 7P / connect. 6P Cable with plug 7W alu. / plug 6W
2	1	6 433 980	Rampe d'éclairage 3.5m VP. Lighting ramp 3.5m VM.
3	2	6 433 986	Support rampe d'éclairage Lighting ramp support
4	2	M 631 100	Etrier □40 - M10 Flange □40 - M10
5	2	M 631 181	Etrier M20 □100 aplati 10.9 Flange M20 □100 flattened 10.9
6	4	VJ 141	Ecrou HEFR M10 emb. S.Lock Cl.10 HEFR M10 Flg nut Gr.10 ZNBL
7	4	VJ 145	Ecrou HEFR M20 emb. S.Lock Cl.10 HEFR M20 Flg nut Gr.10 ZNBL

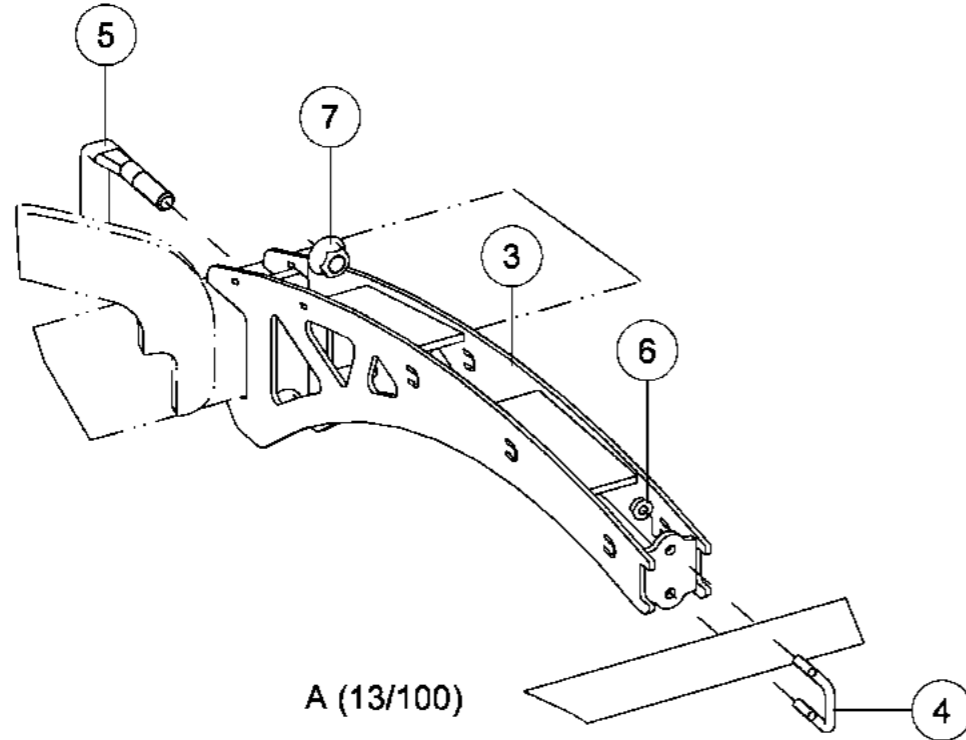
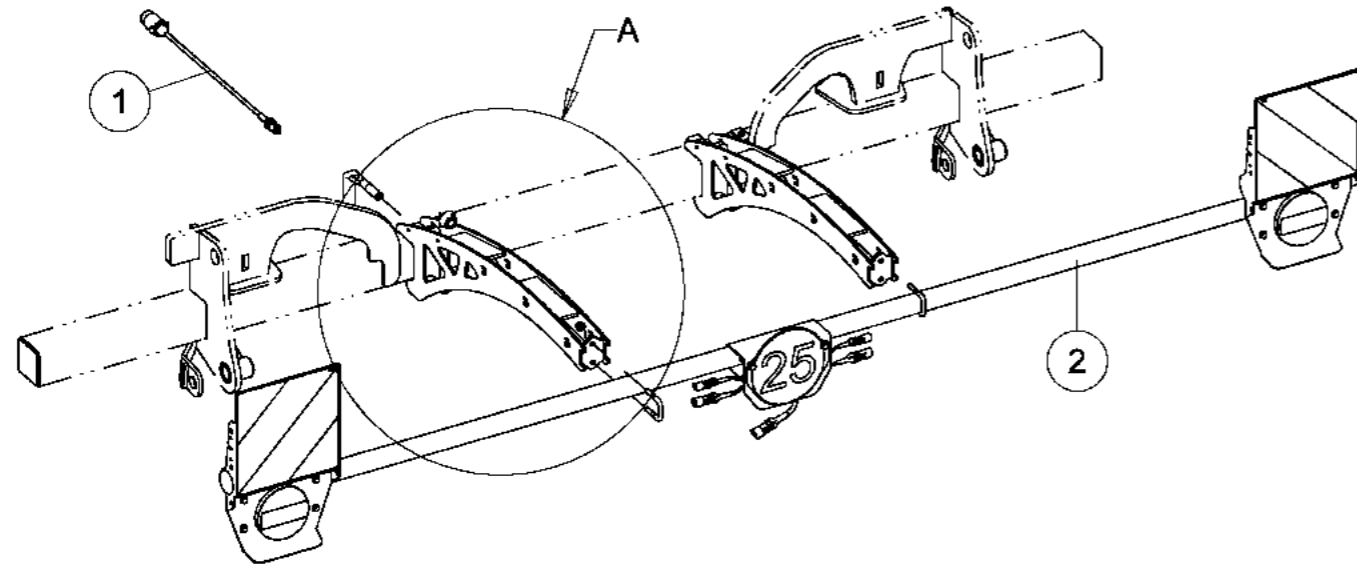

A (13/100)

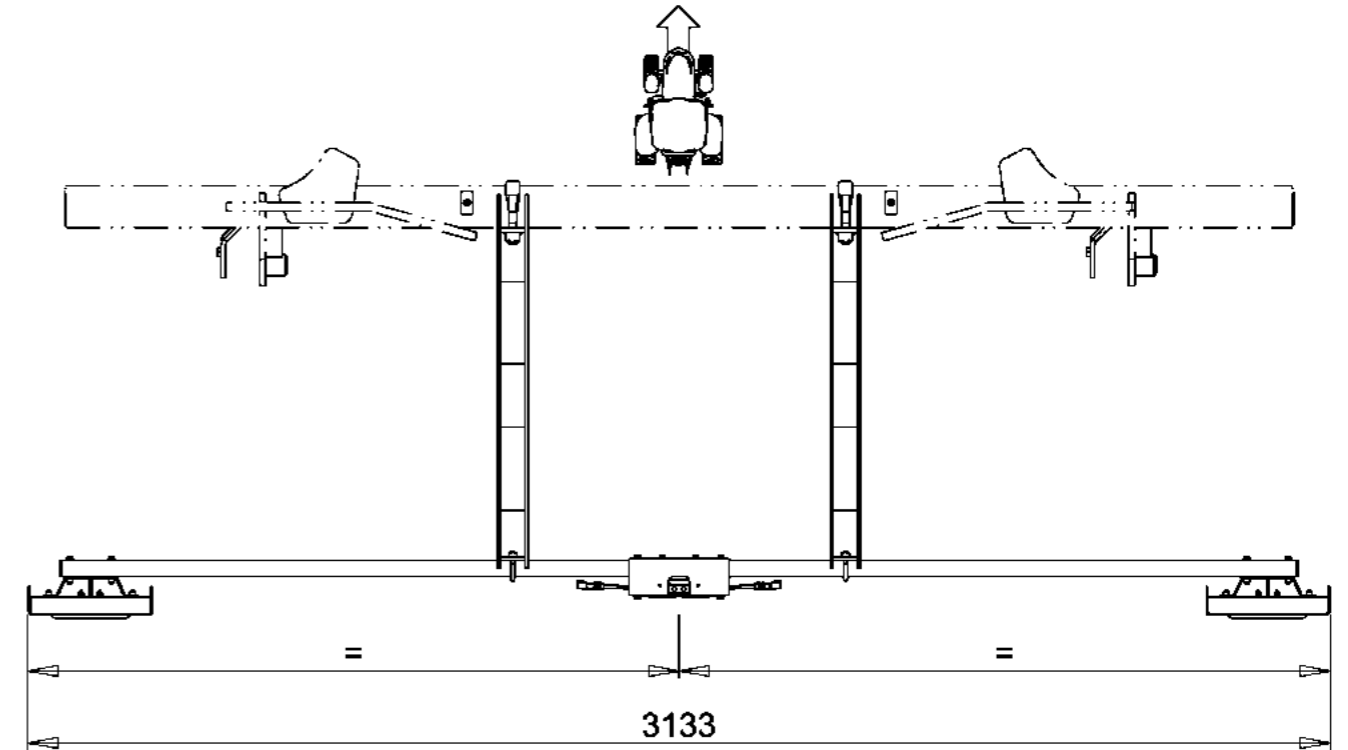

Rampe centrée par rapport à la machine  
/ Ramp centered in relation to the machine

Rampe d'éclairage 3.5m VP.

Lighting ramp 3.5m VM.

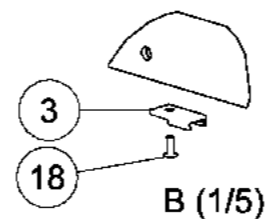
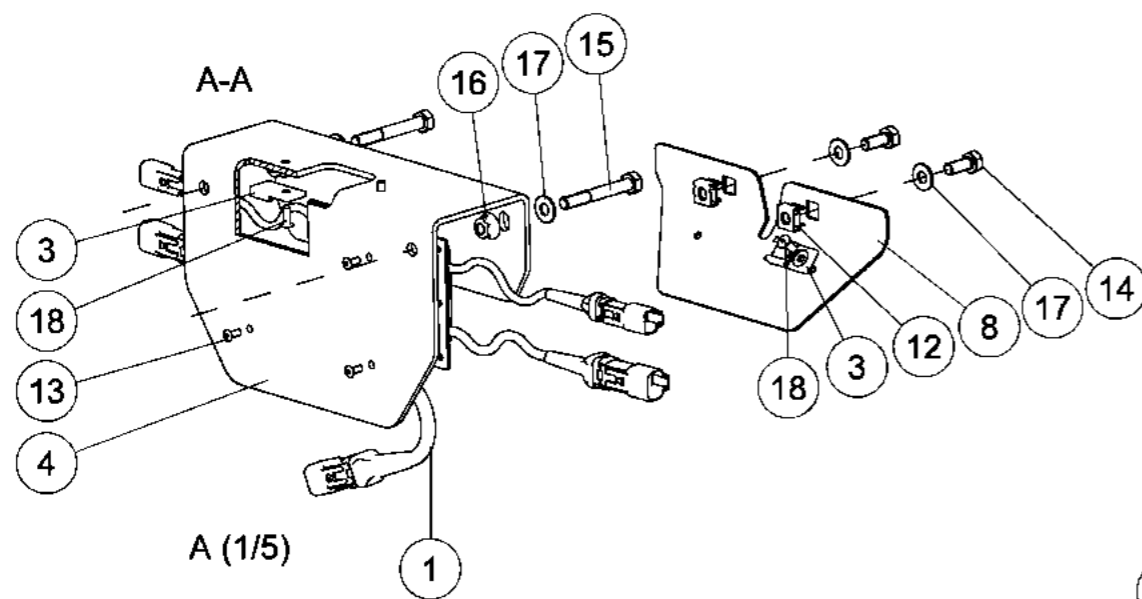
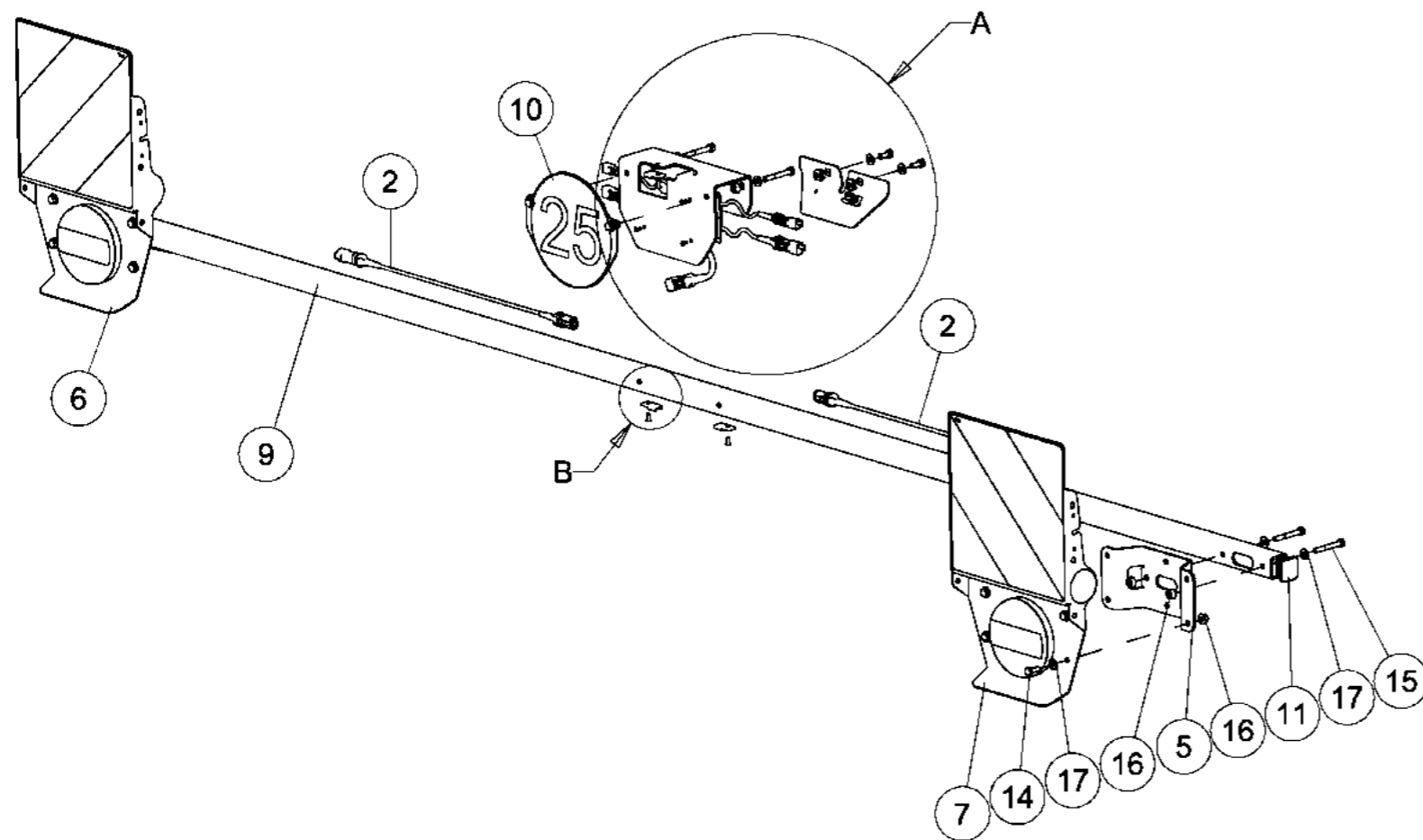

Index	Quantite	Reference	Designation
1	1	1 221 431	Boite de dérivation Distribution box
2	2	1 221 434-1500	Rallonge 4 Plots 4-Way extension
3	5	1 222 318	Clip de montage connect. femelle Mounting clip for pins
4	1	6 433 933	Support central boîtier de deriv. Distribution box central support
5	2	6 433 944	Support Support
6	1	6 433 945	Module d'éclairage VP Gch. Lighting unit VM LH
7	1	6 433 946	Module d'éclairage VP Drt. Lighting unit VM RH
8	1	6 433 963	Protection centrale Central protection
9	1	6 433 977	Tube rampe d'éclairage 3.5m Light ramp tube 3.5m
10	1	6 433 994	Module panneau 25km/h 25km/h sign unit
11	2	850 100 373	Bouchon plast. pour tube 40x40x4 Square plastic plugs LQ40x40x4
12	2	851 055 793	Ecrou à cage M8 Cage nut M8
13	4	7337D410AL	Rivet "Pop" 4.0x10 Rivet "Pop" alu Dia 4.0x10
14	10	VI 27 04	Vis H M8x 20 - 8.8 ZNBL Screw H M8x 20 - 8.8 ZNBL
15	6	VI 27 11	Vis H M8x 60 - 8.8 ZNBL Screw H M8x 60 - 8.8 ZNBL
16	14	VJ 140	Ecrou HEFR M8 emb. S.Lock Cl.10 HEFR M8 Flg nut Gr.10 ZNBL
17	16	VK 502	Rondelle plate MU8 ZNBL Flat washer MU8 ZNBL
18	5	VM 414	Rivet "Pop" 4.8x12 Rivet "Pop" alu Dia 4.8x12

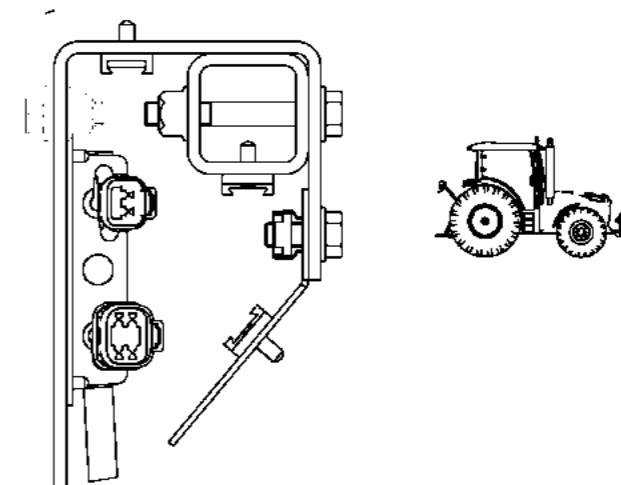



Notes / Notes / Anmerkung / Note / заметка



**RABE**

A series of horizontal dotted lines for writing notes.





---

## **RABE**

ZI Nord Les Gaudères  
37130 Langeais  
**France - Frankreich**

Tel. (+33) 2 47 96 72 61  
Fax (+33) 2 47 96 71 85  
info@rabe-gb.fr  
www.rabe-gb.fr

---

## **RABE**

Am Rabewerk 1  
49152 Bad Essen  
**Allemagne - Deutschland**

Tel. +49 (0) 54 72 771 - 0  
Fax +49 (0) 54 72 771 -195  
info@rabe-gb.de  
www.rabe-gb.de