

ADDENDUMS OPERATING INSTRUCTIONS

(TRANSLATION OF ORIGINAL VERSION DE)

EN

TETRA L

Addendum to Tetra L 9901.00.02EN01GB operating instructions



Contains important information on start-up.
Read before the first start-up and before the first folding together.

CONTENT

ADDENDUM TO TETRA L OPERATING INSTRUCTIONS 3

- 1 Clearance required for new generation of wheel mark eradicator (as of 01/2016)..... 3
 - 1.1 Variants.....3
 - 1.2 Dimensions of the new generation wheel mark eradicator3
 - 1.3 Clearance required (a) - distance from circumference of wheel to centre of catching hook4

ADDENDUM TO TETRA 4501 L/LS AND 6001 L/LS 5

- 1 Number of installable wheel track eradicators, 6258 series from year of construction 2012 5

ADDENDUM TO TETRA WITH HYDRAULIC TINE TRAILER 6

- 1 Dismantling after container delivery 6
 - 1.1 Do not move the tine field to the rear.6
 - 1.2 Fit support wheels.6

ADDENDUM TO TETRA 7501 L, 9001 L . 7

- 1 Dismantling after delivery 7
 - 1.1 Remove the transport lock of the tine field.....7

ADDENDUM TO TETRA 7501L, 9001 L AND TETRA 4501 LS WITH CROSSKILL ROLLER 8

- 1 Switch off the machine 8

ADDENDUM TO TETRA 6001 L WITH TOOL CARRIER FOR MARK ERADICATOR 9

- 1 Switch off the machine 9





This addendum is only valid in conjunction with the specified operating instructions.

- Follow the safety instructions of the operating instructions for the basic machine.
- Before start-up, read and take note of the operating instructions and addendum.
- Retain for future reference.

ADDENDUM TO TETRA L OPERATING INSTRUCTIONS

1 CLEARANCE REQUIRED FOR NEW GENERATION OF WHEEL MARK ERADICATOR (as of 01/2016)

1.1 Variants

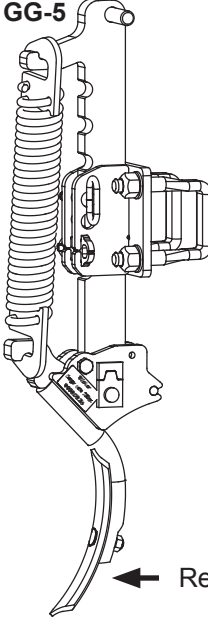
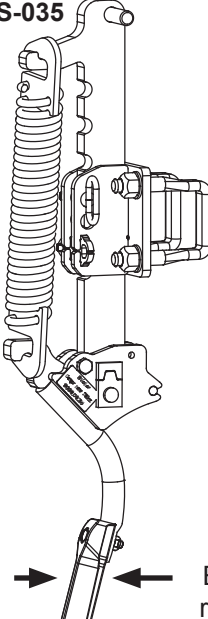
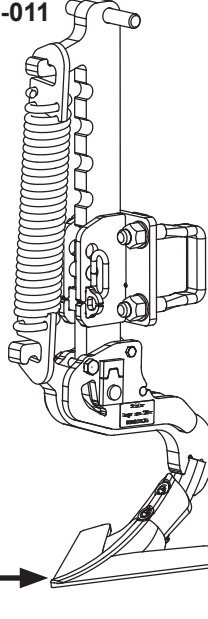
	RSL GG-5	RSL GS-035	RSL GG-011
			
Delivery quantity	← Replaceable blade →		← Blade NOT replaceable →
ex works	4 (2+2)	4 (2+2)	2
maximum installable	8 (4+4)	8 (4+4)	4 (2+2)

1.2 Dimensions of the new generation wheel mark eradicator

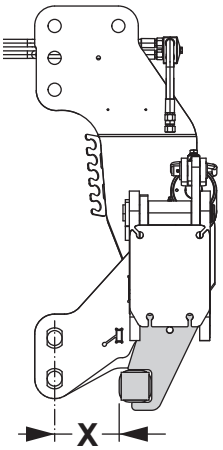
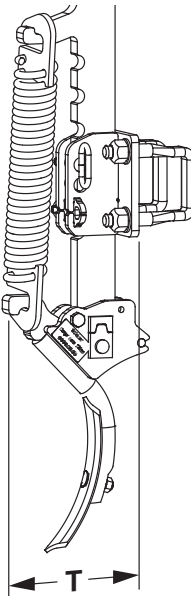
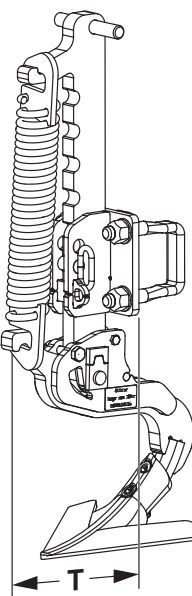
				
Tetra, version	Year of construction	Distance X	Installation depth T for all wheel track eradicators	
3001 L 4501 L 4501 LS 6001 L 6001 LS	up to 2015	102 mm	← T →	
3001 L 4501 L 4501 LS 6001 L 6001 LS	as of 2016	162 mm		
7501 L 9001 L		90 mm		
			← T →	
			approx. 200 mm	

1.3 Clearance required (a) - distance from circumference of wheel to centre of catching hook

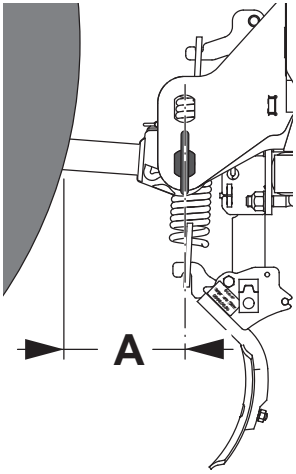
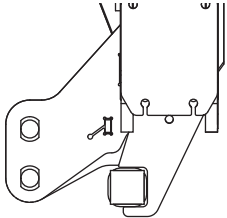
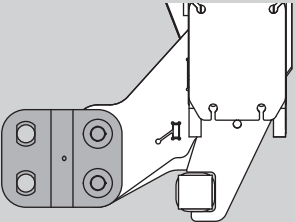
Distance	Connection situation	a = required distance		
		7501 L 9001 L	3001 L 4501 L 4501 LS up to 2015	6001 L 6001 LS as of 2016
	Standard version 	≥ 180 mm	≥ 170 mm	≥ 110 mm
	Version with projection set (6258.90.20) 	≥ 30 mm	≥ 20 mm	≥ - 40 mm

ADDENDUM TO TETRA 4501 L/LS AND 6001 L/LS

2 NUMBER OF INSTALLABLE WHEEL TRACK ERADICATORS, 6258 SERIES FROM YEAR OF CONSTRUCTION 2012

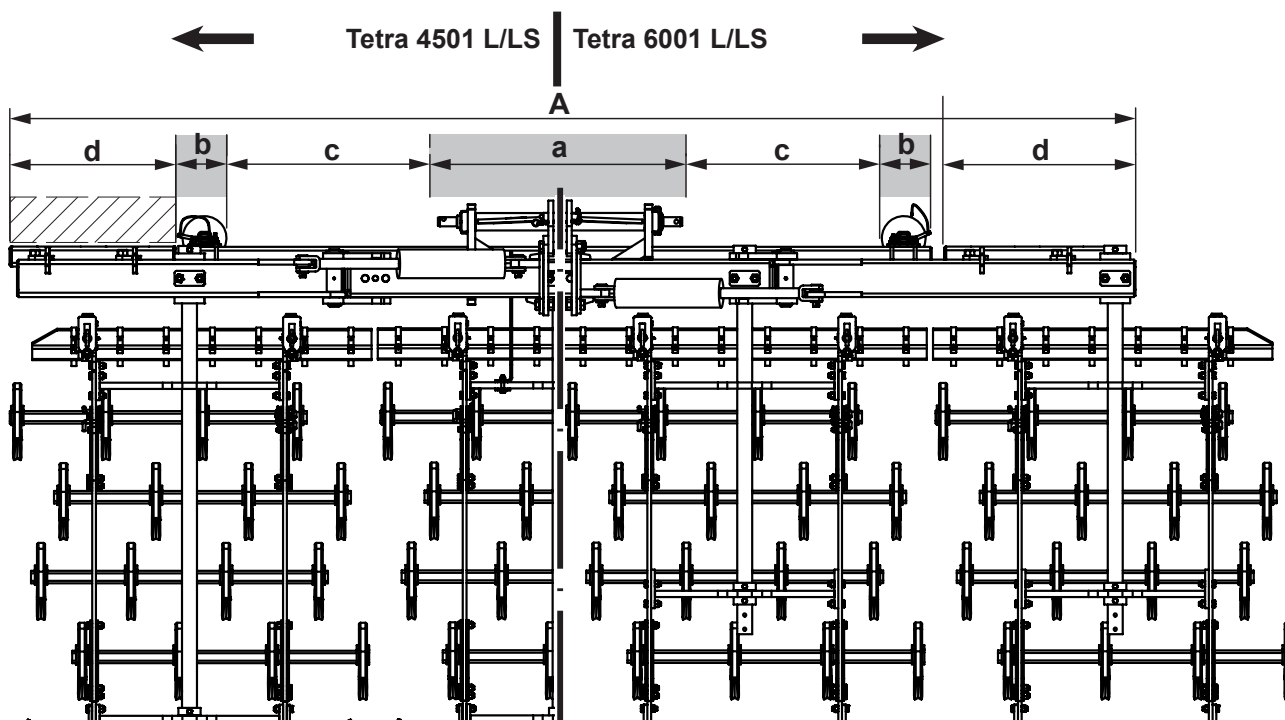

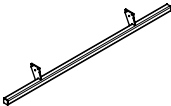
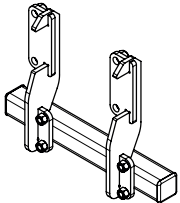
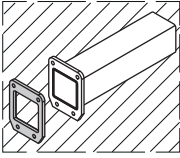
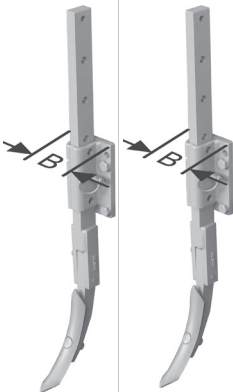
Model	Width A	Tilled area		Cultivable area in combination with additional equipment		Number of installable wheel track eradicators*				
		a	b	Central tool carrier c	Lateral tool carrier d	Var. 1 6241.29.00 W=100	Var. 2 6241.94.00 W=100	Var. 3	Var. 4	
					 					
Wdth.0	3001	3000	1100	180	950		4 / 10	4 / 10		
	4501	4500	1100	180	950		4 / 10	4 / 10		
						650	4 / 6	4 / 6		
					950	650	8 / 16	8 / 16		
6001	6000	1100	180	950			4 / 10	4 / 10		
					650		4 / 6	4 / 6		
				950	650		8 / 16	8 / 16		

All dimensions in mm.

* _ / _ = standard assignment/maximum assignment

(1) = side frame broadening with weld-on flange for retrofitting up to mach. no.

ADDENDUM TO TETRA WITH HYDRAULIC TINE TRAILER

3 DISMANTLING AFTER CONTAINER DELIVERY



Do not fold together before dismantling.

2.1 Do not move the tine field to the rear.

Position when delivered

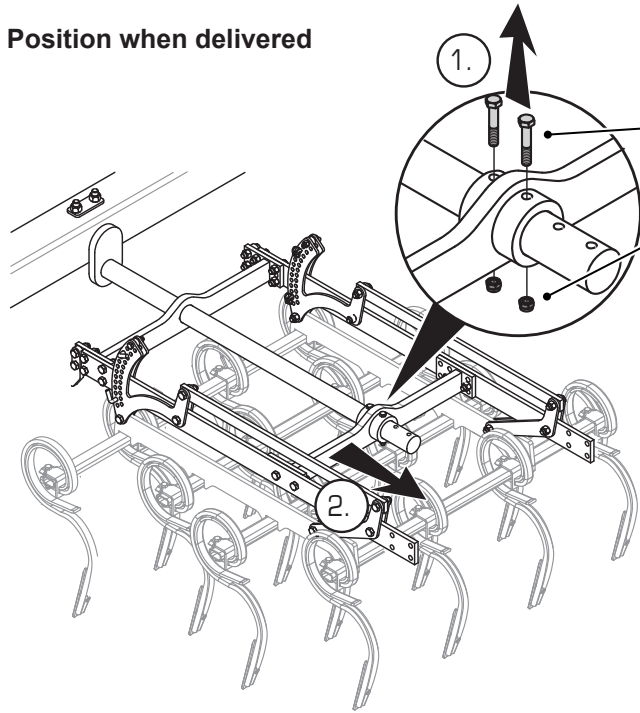

Working position

M12 x 110; 10.9
137 Nm; 101 lb/ft
19 mm

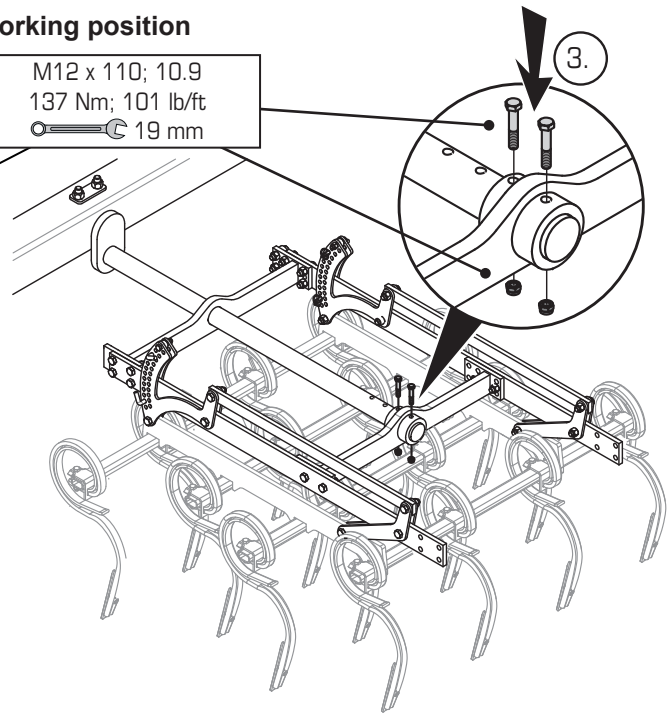

2.2 Fit support wheels.

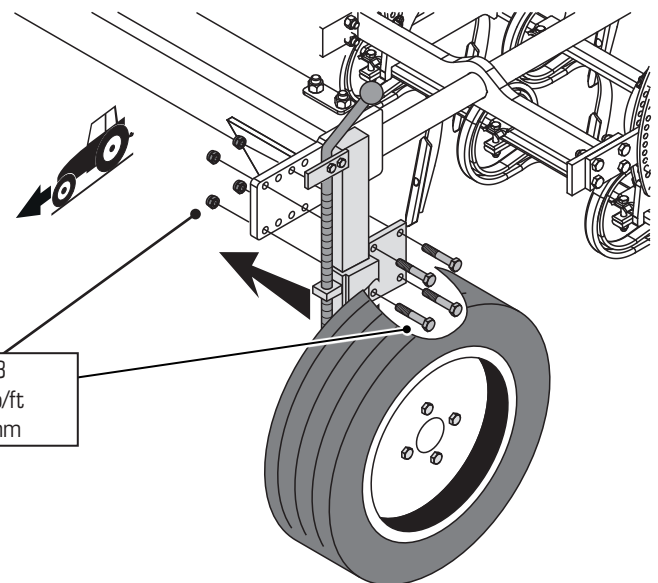
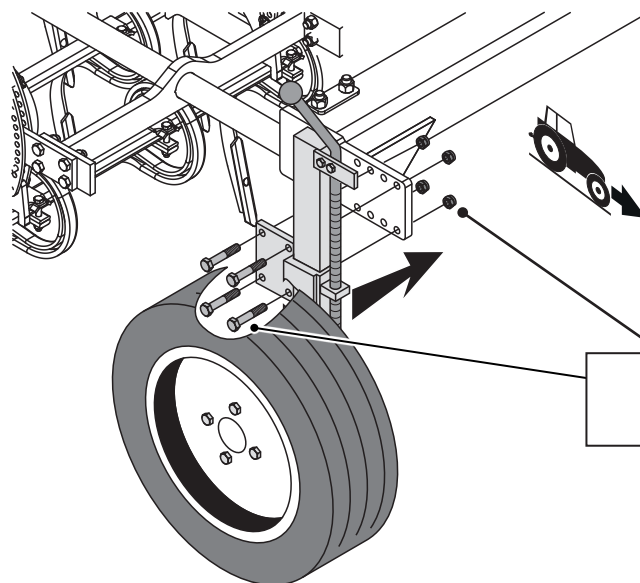

M16 x 55; 8.8
230 Nm; 170 lb/ft
24 mm

ADDENDUM TO TETRA 7501 L, 9001 L

4 DISMANTLING AFTER DELIVERY



Do not fold together before dismantling.

3.1 Remove the transport lock of the tine field.

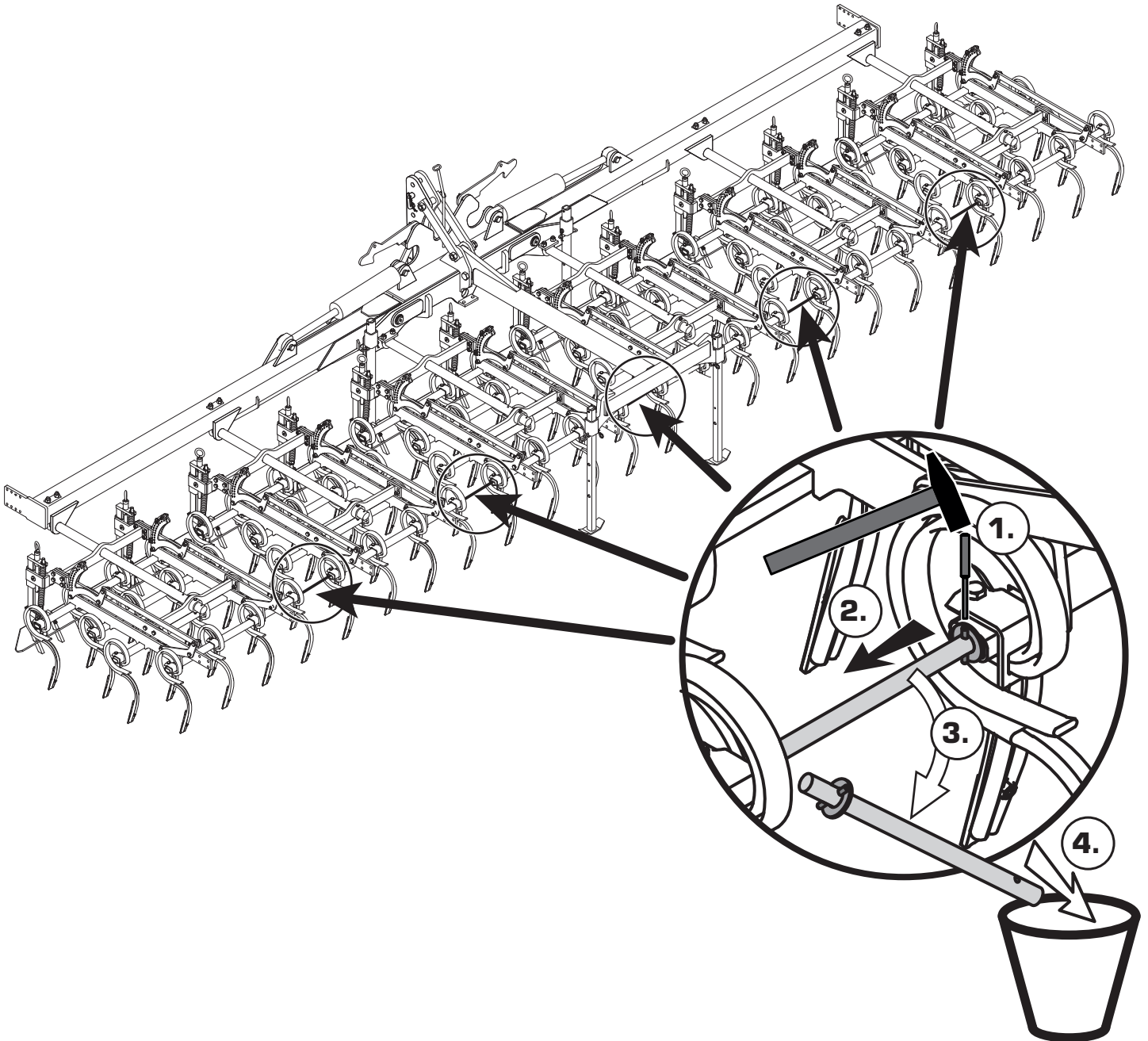

ADDENDUM TO TETRA 7501L, 9001 L AND TETRA 4501 LS WITH CROSSKILL ROLLER

5 SWITCH OFF THE MACHINE

Concerning:

Tetra 7501L, 9001L and 4501 LS with Crosskill roller without rear parking supports.



DANGER
Danger of tipping in machines without rear parking supports.

- Only park named machines folded out.

Rear parking supports

Tetra 4501 LS

Tetra 7501 L

Tetra 9001 L

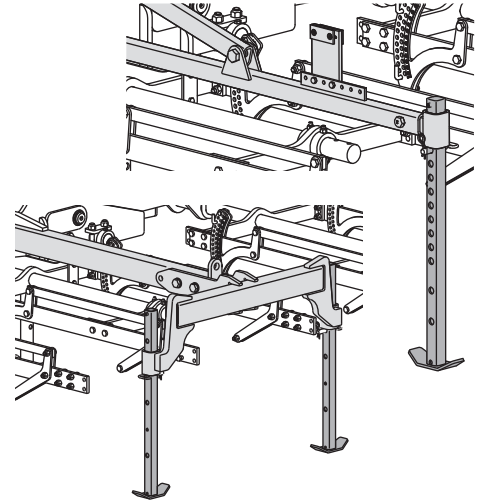

Example: Tetra 4501 LS with Crosskill roller folded out

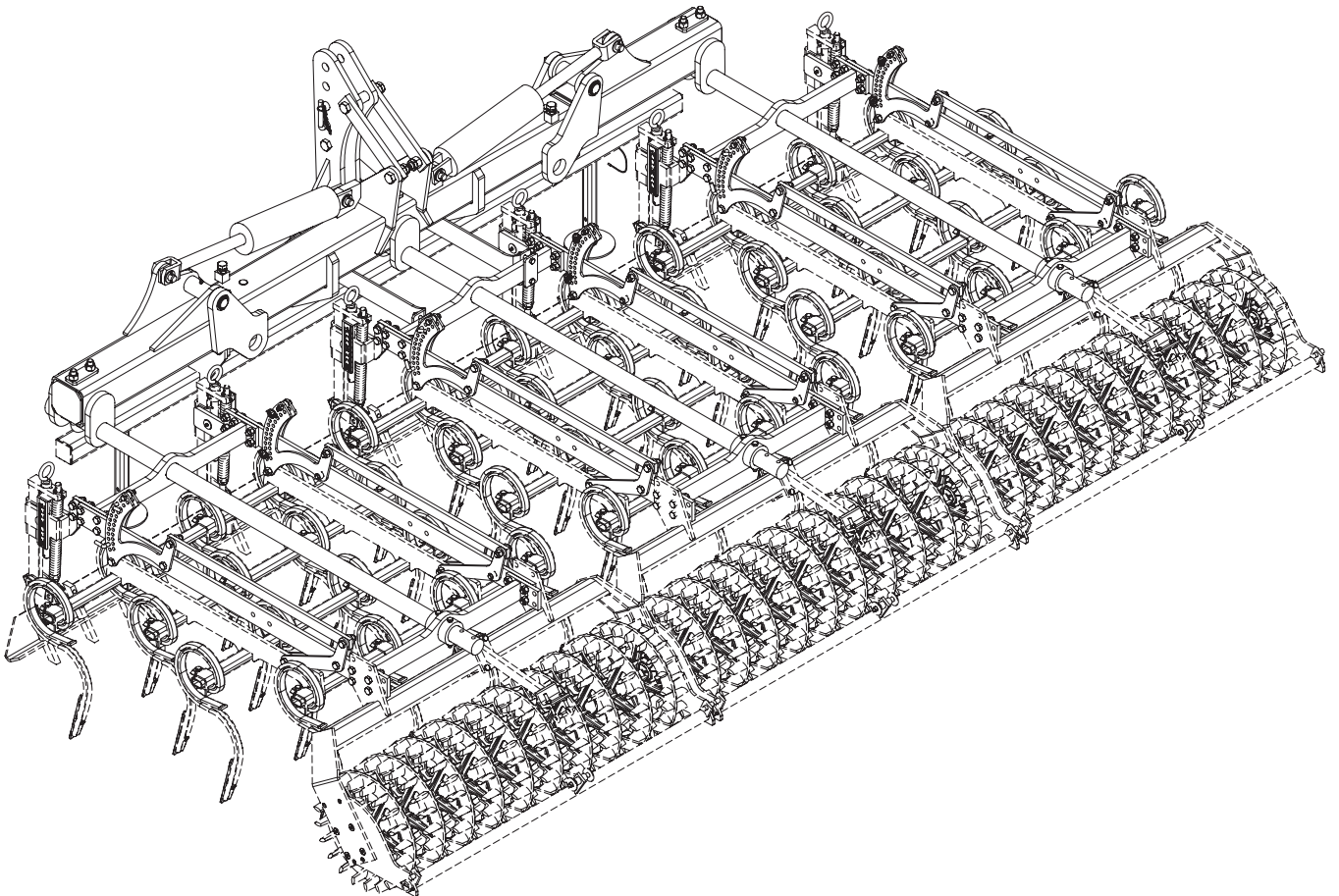

ADDENDUM TO TETRA 6001 L WITH TOOL CARRIER FOR MARK ERADICATOR

6 SWITCH OFF THE MACHINE



Attention! Transport width of 3.0 metres exceeded.

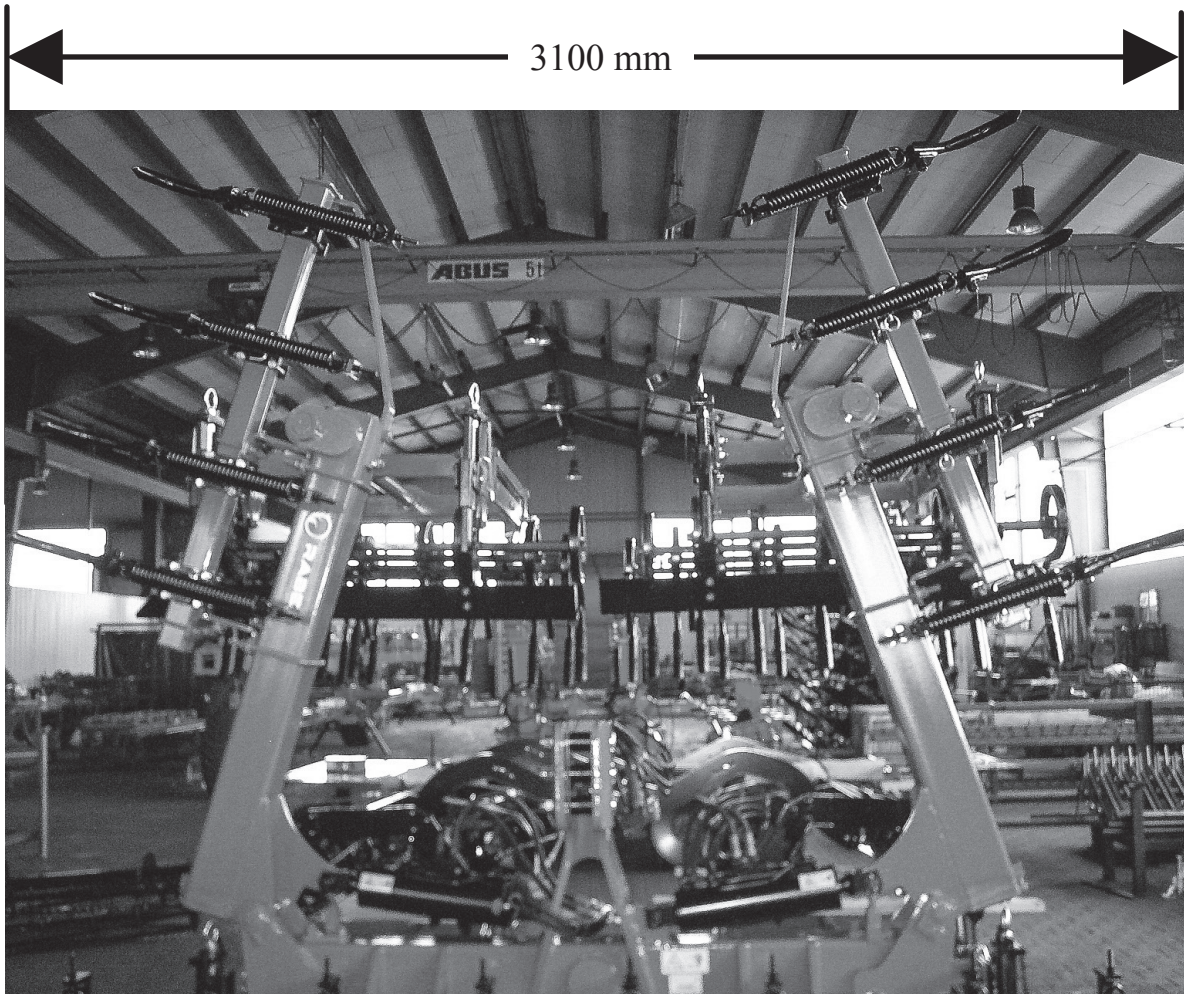

NOTE

Before transport, set all wheel track eradicators up to the lowest working depth.

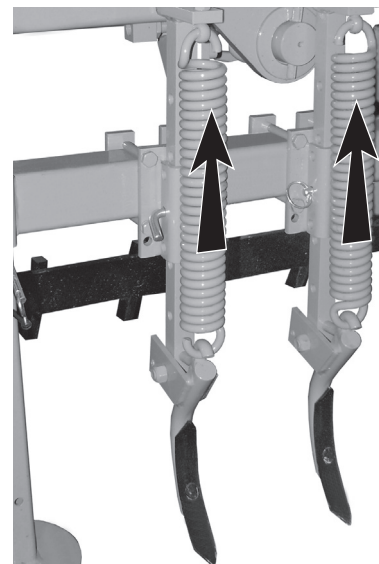



RABE

Am Rabewerk 1
49152 Bad Essen
Germany

Tel: +49 (0) 54 72 771 - 0
Fax +49 (0) 54 72 771 -195
info@rabe-gb.de
www.rabe-gb.de