



Order-No. 9900.01.08GB03

Operating Instructions **MegaSeed**



Read and follow the safety instructions!

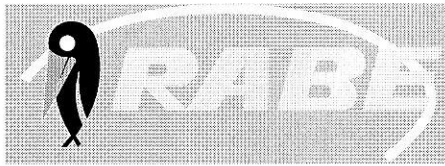

EC Declaration of Conformity

(Directive 89/392/EEC, Annex II, sub A)

We ***RABE Agrarsysteme GmbH+Co.KG***

Am Rabewerk, D-49152 Bad Essen

Declare under our sole responsibility, that the product

Min-Till Seed Drill *MEGASEED*

is in conformity with the provisions of the following other EEC directives:

Directive 89/392/EEC
93/44/EEC and 93/68/EEC, Annex I

To ensure the proper implementation of the EU's Health and Safety Guidelines,
the following norm(s) and/or specification(s) has/have been given consideration:

EN 292-1 and EN 292-2

Bad Essen

17.07.2002

Wilhelm von Allwörden,
Managing Director

Friedrich Gerdom,
Head of Design



Operating instructions

MegaSeed

Before operating the seed drill for the first time, please read carefully through these operating instructions and the safety precautions ("For your own safety") and ensure that they are observed.

Ensure that the operators are properly qualified, trained in its use and everyday maintenance, and familiar with the hazards. Make sure that other users are supplied with the safety precautions.

Ensure that all applicable accident prevention regulations are observed, along with other generally recognized safety procedures and any legislation that may apply with respect to road traffic and to health and safety in the workplace.

Observe the warning labels at all times! (DIN 4844-W9)

Instructions in this manual which are marked with this symbol, and its presence on the unit, warn of danger (for explanation see appendix).



The 'Beware' symbol indicates safety instructions which, if not observed, may cause danger to the unit and its operation.



The 'Note' symbol indicates machine-specific instructions which should be followed for trouble-free operation of the unit.



Loss of warranty

This trailed seed drill is designed and built exclusively for standard agricultural use. Use for any other purpose will be regarded as unauthorized operation and no liability whatsoever will be accepted for any damage or injury that may occur as a result.

The term "authorized operation" also covers the full observance of all operating, maintenance and servicing specifications and the exclusive use of original spare parts.

The use of non-original accessories, spares and/or consumables that do not carry specific approval from RABE shall void all warranty liabilities.

We accept no liability for damage, loss or injury resulting from the carrying out of unauthorized repairs and/or modifications to the unit nor from failure to supervise its use.

Delivery claims (transit damage, missing parts) should be made immediately and in writing.

Warranty claims, warranty conditions and our liability exclusions are based on our general terms of delivery.

Table of contents	Page
Description of unit	5
Machine data	6
Safety precautions	8
Commissioning and use	9
1. Connection	10
1.1 Coupling the unit	10
1.2 Brakes	10
1.3 Electrical connections	10
1.4 Hydraulic connections	10
2. Laying up the unit	11
2.1 Disconnecting brakes	11
2.2 Hydraulic connections	11
2.3 Electrical connections	11
3. Preparation for transport	12
3.1 Unit	12
3.2 Rear Harrow	12
3.3 Marker arms and ground wheel	12
3.4 Retraction of coulter bar and tilling tools/rollers	12
3.5 Safety	13
4. Conversion to operational mode	14
5. Commissioning and set-up	14
5.1 Soil preparation	14
5.1.1 Turbo tiller	14
5.1.2 Mulch disc unit	14
5.1.3 Harrow tines	14
5.1.4 Front tine levelling board and wheel mark eradicators	14
5.2 Rollers	15
5.2.1 Toothed packer roller	15
5.3 Coulter bar	15
5.3.1 Setting the coulter pressure	15
5.3.2 Setting the sowing depth/pressure roller	15
5.4 Rear harrow	16
5.5 Marker arms	16
5.6 Sowing and metering	17
5.6.1 Calibration	18
5.7 Tramline marking	19
5.8 Radar	19
5.9 Power supply	19
6. Fan speed	20
7. Recommended metering settings on Rabe pneumatic seed drills with hydraulic fan drive	21
7.1 Exchanging metering wheels on pneumatic seed drills	22
8. Distributor head/tramline	23
9. Checking sowing precision on seed drills with electrically driven metering wheel	24
9.1 Tips for use	24
10 Maintenance	25
10.1 Fuses	26
10.2 Faults and their resolution	27
11 Transport precautions	30
12 Positioning of warning symbols on the unit	31

Description of unit

The Turbodrill MegaSeed is a trailed seed drill with a working width of either 3m, 4m, 4,5m and 6m. The seed rows are 12.5 cm apart.

Thanks to the design of its seed coulters, the seed drill is suitable for conventional drilling of ploughed land (even if the seed-bed has been poorly prepared), and equally for mulch drilling / Min Till (conservational soil preparation).



This is where the machine sows in a mixture of soil and chopped plant remains (surface mulch) which has been created through a previous operation.

In light soil conditions, mulch sowing as a direct process is also possible, i.e. without the soil having been prepared beforehand, sowing is possible by taking advantage of the machine's own cultivating effect.

The MegaSeed may optionally be equipped with a twin-row Turbo Tiller, a harrow combination with two rows of steeply angled 'Vibra-tines' or two rows of dragged tines, or with a set of double row mulch discs. The tilling tools are combined respectively with a GZW toothed roller (diameter 660mm), a MPW mulch roller (diameter 640mm), or a SPW cage roller (diameter 640mm).

'Vibra-tine' wheel mark eradicator tines

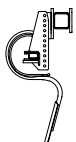

hydr. adj. Turbo Tiller

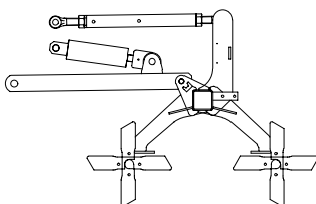

hydr. adj. disc set

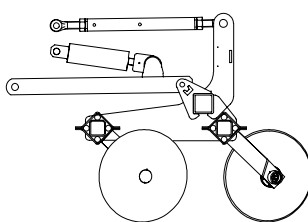

hydr. adj. tine levellingboard steeplyangled 'Vibra-tines'

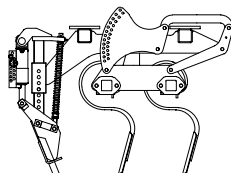

Toothed packer roller GZW

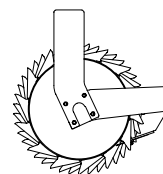

Mulch roller MPW

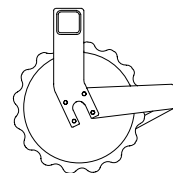

Machine data

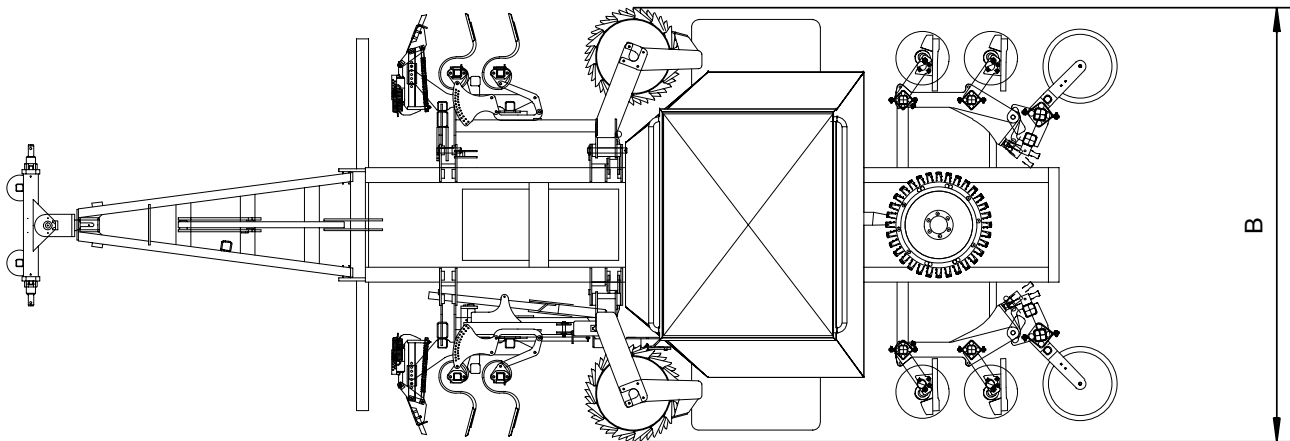
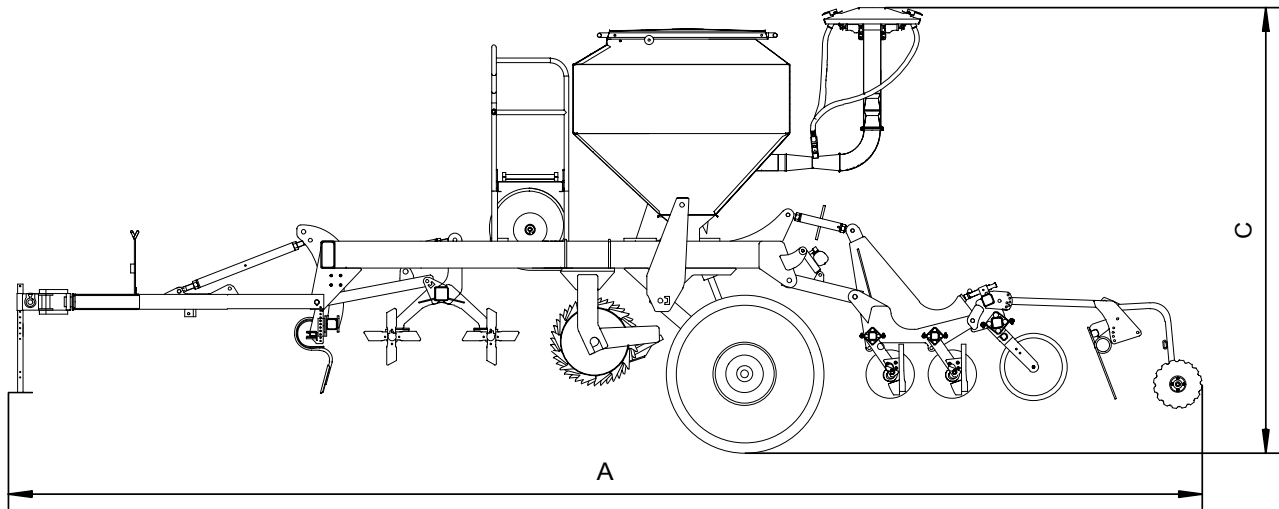

MegaSeed				
Model	MegaSeed 3m	MegaSeed 4m	MegaSeed 4,5m	MegaSeed 6m
Unladen weight kg (ca.) Leergewicht in kg (ca.)	4560	5620	6680	9695
Min horse power requ. (kW/HP)	88/120	110/150	117/160	147/200
Working width in mm (approx.)	3000	4000	4500	6000
Length A in mm (approx.)	9000			9820
Transport width B in mm (approx.)	3000			
Transport height C in mm (approx.)	3000			3750
Maximum supported load	1500			1165
Maximum overall weight	8750			11500

Dimensions and weights are for basic models

Subject to technical change without notice

Machine data

MegaSeed				
Basic model	MegaSeed 3m	MegaSeed 4m	MegaSeed 4,5m	MegaSeed 6m
Seed hopper content	2300 litres			3500 litres
Number of rows (row spacing=125mm)	24	32	36	48
Tyres (low pressure)	600/50-22.5			700/45-22.5
Brake system	Air or oil brakes			
Seed distributor	pneumatic			
Metering drive	Electronically controlled electric motor			
Fan drive	Blade wheel blower with hydraulic motor			
Hitching	Lower links category III N (narrow) or drawbar hitch (pin hole dia 41 mm)			
Hydr. spool valves required	2 x double acting, 1 x single acting, 1 x unpressurised return pipe			
Hydraulic pressure	200 bar maximum			
Control/monitoring system	electronic			
Working speed	Up to 15 km/h			
Speed on public roads	25 or 40 km/h* * depending on traffic permit			

Noise level for driver when machine is running is less than 70dB(A)

Safety precautions

DO not allow anyone to stand between the tractor and the unit during coupling or uncoupling. Note that this includes stepping between the tractor and unit to operate the external hydraulic controls! Risk of injury!



Set the tractor's hydraulic lifting system to "position control" before coupling and uncoupling!

Before operating the tractor and the unit, always ensure that they fulfil operating and road traffic safety requirements. Observe permitted axle loads (with full seed hopper), and overall weight! When transporting, all necessary protective equipment must be available and in place!

Before starting or operating the unit, always check to ensure that no one is standing within its turning circle or operating area. Also take into account the reach of the marker arms!

DO NOT stand or ride on the unit or remain within its turning circle or operating area!

Before leaving the tractor unattended or performing adjustments or maintenance, lower the unit front and rear, switch off the engine and remove the ignition key!

There is danger of crushing and shearing within the areas of the three point linkage, the hydraulic extension and retraction gear, the marker arm mechanism!

Danger exists from disc and roller parts continuing to rotate if the unit is raised while moving at high speed. Only approach these parts after they have ceased to rotate!

Handle hydraulic transmission components and hoses with care, as they become hot during operation!

Immediately shut down the hydraulic drive if the blower begins to vibrate – then check the fan blade wheel as it has been dynamically balanced! Imbalance indicates danger and damage to the blower

Before maintenance or adjustment of the metering equipment, and when travelling on public roads, switch off the electronic system (to '0') and make the unit free of current (disconnect the supply and unit circuits)!

When transporting, lock the tractor's hydraulic control unit against accidental activation!

Only carry out adjustment or other work on the unit when it has been lowered front and rear!

When filling the hopper with dressed seeds, and cleaning the unit with compressed air, beware that dressing is poisonous. Protect sensitive body parts accordingly (e.g. protective goggles, mouth protection, gloves). Before the first use, and after a long period of disuse, ensure that all bearings are sufficiently lubricated, that all screws are tightened, that the hydraulic equipment has no leaks, and that the tyre pressure is correct!

- maximum overall length (tractor + unit) 18m
- width from 2.55m to 3m maximum
- maximum height 4m
- maximum overall weight of the combination 16t, of which 20% on the front axle
- maximum working pressure of the hydraulic system 200bar
- the manufactures plate **(1)** is documentary evidence, and must not be tampered with or defaced.



Typ:		
Fz.-Ident.-Nr.		
zul. Stuetzlast		kg
zul. Achslast		kg
zul. Gesamtgewicht		kg
Eigengewicht		kg
Baujahr:	Nr.	

Rabe Agrarsysteme
GmbH & Co. KG,
D-49152 Bod. Essen

1

Operating and functions

The unit is used in "position control" when working.

The desired sowing depth is achieved by adjusting the spindles **(4/1)** which are close to the rear pressure rollers **(4/4)**.

These rear rollers ensure that the earth is well firmed over, and at the same time guarantee a consistent sowing depth. The broad flexible 'firming tyres' stop loose earth from falling in, as well as a build up of earth where the soil is sticky.

The notched sowing discs **(4/2)**, which are fitted with ball bearings, clean the seed rows of plant residues. In their 'shadows', the integrated sowing units **(4/3)** place the seed.

The high pressure (up to 80bar) allows the sowing units to work smoothly even at high working speed, and thus contribute to an even sowing depth even when soil conditions are changeable.

If the soil has an insufficient load bearing capacity, the undercarriage can be lowered to relieve the coulters when tilling.

The rear harrow can be adjusted to the current soil conditions by adjusting the its steepness, and it will run without becoming blocked, even when there is a high proportion of plant residue.

The models with Turbo Tiller and with mulch discs are particularly recommended for work with a high proportion of plant residue and trash, because only rotary implements are in use in the overall combination.

This combination is less aggressive than the models with 'Vibra-tines' or dragged tines, which for example are very suitable for sowing ploughed land with a coarse soil structure.

The electronically controlled metering unit allows an exact quantity setting, and with the patented pre-metering unit, offers the possibility of starting sowing from the initial standing position, thus avoiding unsown areas (sowing windows) at the beginning of a session.

The centre marking markers can be hydraulically folded in an up right position within the working width of the seed drill.

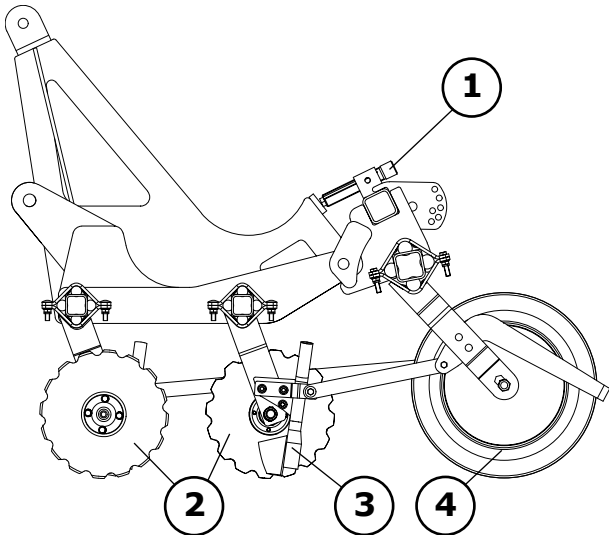

4



5

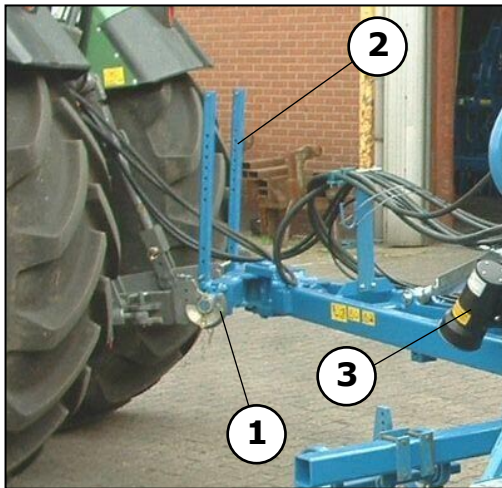

6

1. Connection

1.1 Coupling the unit

Connect the lower link cross shaft **(6/1)**.
Secure the coupling unit correctly.
Lock the tractor's lower link arms in a central position.

Raise the support stands **(6/2)**.

1.2 Brakes

Connect the yellow brake hose **(7/2)**.

Connect the red brake hose **(7/1)**.

The spring brake releases itself once the pressure has built up in the system.

1.3 Electrical couplings

There are three electrical connections on the front of the machine:

- supply cable **(8/1)** for the metering drive
- control cable **(8/2)** for the drilling computer
- connection cable for the lighting on the trailed seed drill

1.4 Hydraulic couplings

Depending on the model, the following hydraulic couplings are required:

- single acting control unit with an unpressurised return (22 mm diameter) for the hydraulic fan drive (group 4 plug-in coupling).
- Double acting control unit for the under-carriage
- Double acting control unit for the marker arms. As necessary can be switched to adjust the reservoir pressure for applying hydraulic coulters bar pressure.
- Double acting control unit for the front tilling tools or folding in. The desired function can be selected with valve **(8.2/1)**.

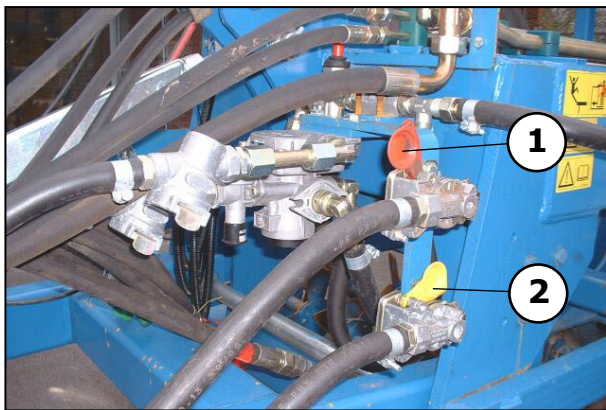

7

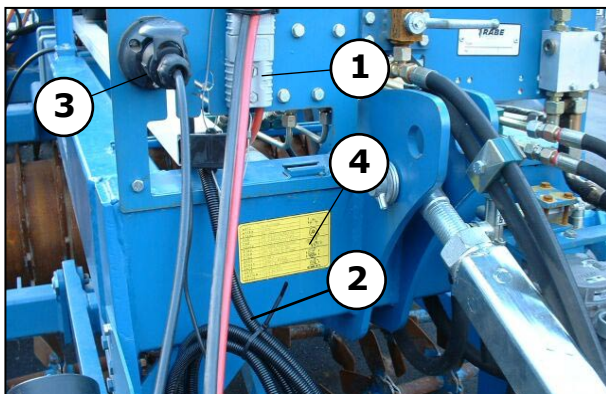

8

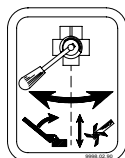

8.1

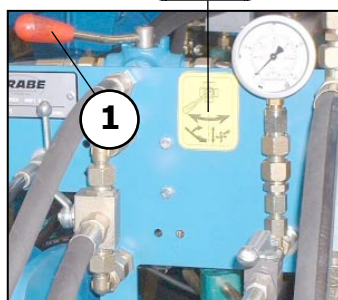

8.2

Expand or retract the MegaSeed only in the fully raised position.

It is forbidden to modify the hydraulic reservoir **(8.1)** mechanically, by welding, or in any other way. Before any work on the hydraulic system is carried out, the liquid in the hydraulic reservoir must be fully relieved of pressure. Maintenance, repair, or removal of parts may only be carried out by trained workshop staff.



9

2. Laying up the unit

The unit may be parked in either the retracted (9) or the extended position.

For overwintering, it is recommended to lay up the unit in the extended position, and to lower it fully.

Laying up when retracted:

Lower the undercarriage as far as possible. Close both shut-off cocks on the undercarriage cylinders (12/1).

In addition, support the unit on both sides of the frame to avoid accidental lowering.

Secure the unit from accidentally rolling away by placing chocks under the wheels (9/1).



9.1

2.1 Disconnecting the brakes

Disconnect the red brake hose and hang it in the support (7/1).

Disconnect the yellow brake hose and hang it in the support (7/2).

The spring brake acts on the undercarriage. When the compressed air reservoir is full, the red knob on the brake valve (10.1/1) can be used to release the brakes once without having to connect the brake hoses.

2.2 Hydraulic couplings

Disconnect all hydraulic couplings from the tractor. Protect the hydraulic couplings from dirt using sealing caps, and hang them on the supports provided.

2.3 Electrical couplings

Disconnect all cable connections from the tractor. Store removable control boxes and cables in a dry place. Carefully cover sockets on the unit and tractor.



10

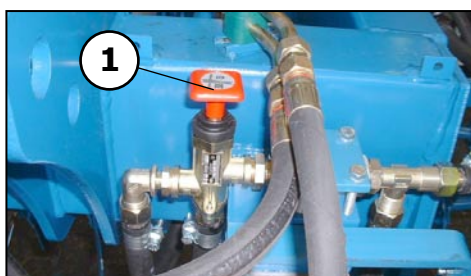

10.1



11



3. Preparation for transport

3.1 Unit

Extend the unit front and rear, so that the frame is extended horizontally. **(11)**

Close the shut-off valves on both extension cylinders. (12/1)

Attention! turn altering spindle (19/1) at transport quite in (19).



12

3.2 Rear Harrow

Set individual harrow elements vertically for transport. Secure with pins **(14/1)**.

3.3 Marker arms and ground wheel (if fitted)

Retract the marker arms and secure with pins **(13/1)**.

Fold up the ground wheel and secure with pin (illustrated: 4 and 4.5m working width).

3.4 Retraction of coulter bar and tilling tools/rollers for 4 and 4.5m working width:

For extension and retraction, the unit must be fully extended **(11)**.

Retract the folding parts using the double acting control unit.

The folding sections are locked hydraulically in the retracted position.

Note: Lock the tractor control valves against accidental use during transport. Switch off and unplug the electronic controls.

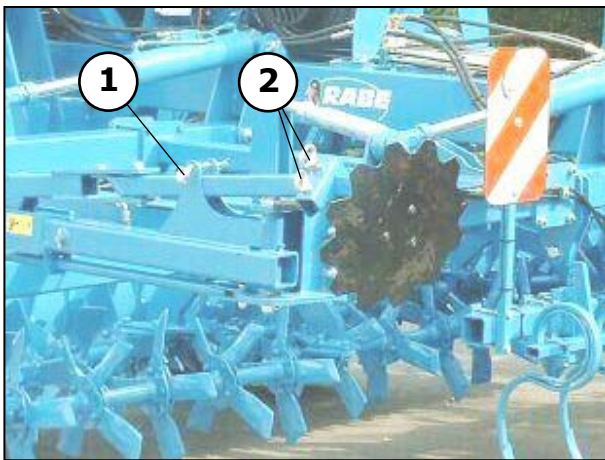

13

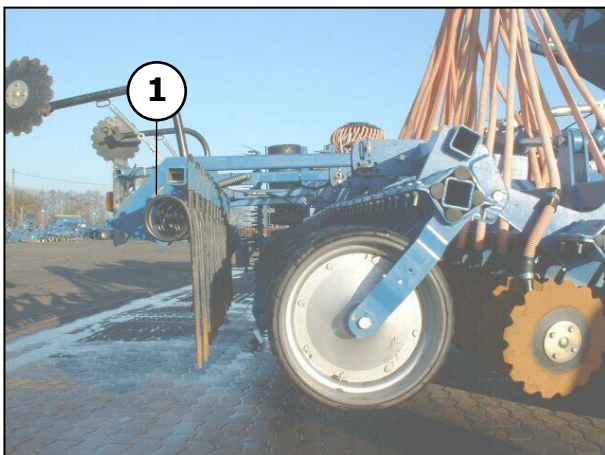

14



14.1

3.5 Safety

The centre of gravity can be lowered for road transport by lowering the unit. This should then give 25 to 30 cm clearance from the ground. **(11)**

(Do not forget to close the shut-off valves)

Before transporting on public roads, protective equipment must be always applied and the unit's lighting must be checked. Observe transport instructions.

4. Conversion to working position

Extend the extensible tools and coulter bars using the double acting control valves (from 4m +).

Extend the cylinders fully.

Open both shut-off valves on the undercarriage cylinders. **(12/1)** Lower the unit front and rear.

Bring the marker arms **(14.1/1)** ground wheel and rear harrow **(14/1)** into their working positions.

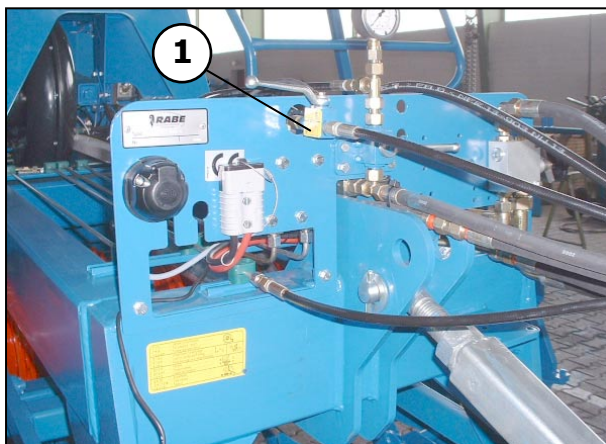

50

Attention: For the 3m machine, the shut-off valve (50/1) must be put into the closed position before transporting.

Switch on the electronic controls.

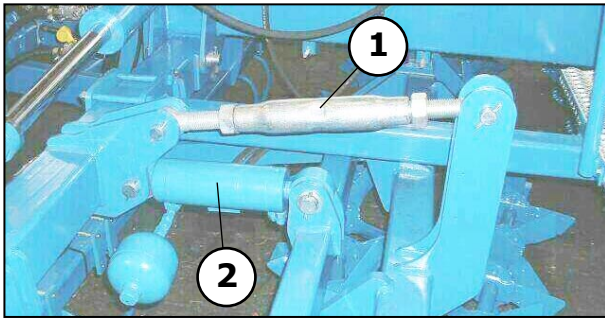

15

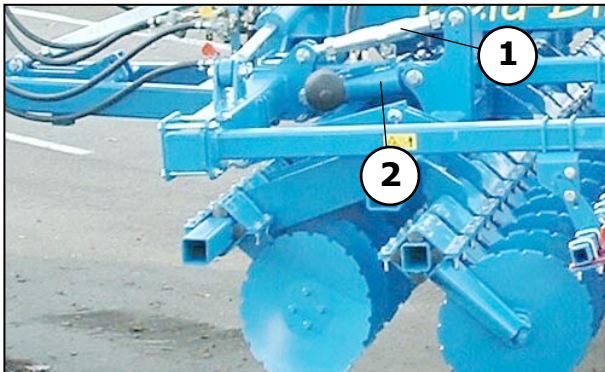

15.1

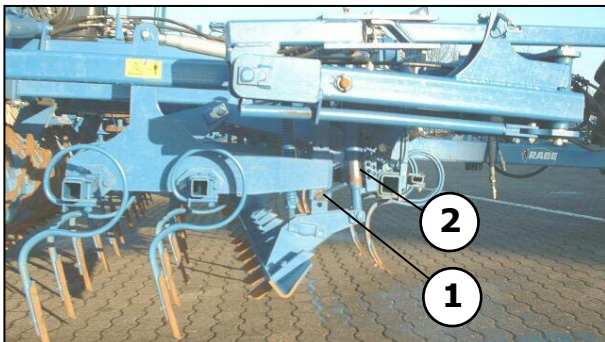

16



16.1

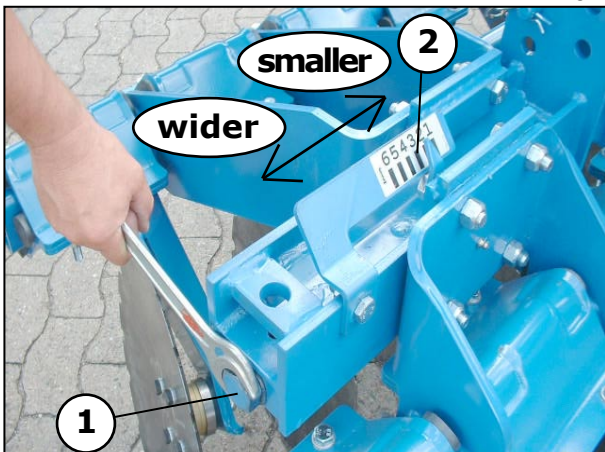

17.1

5. Operation and set-up

5.1 Soil preparation

5.1.1 Turbo Tiller

The working angle of the twin-row Turbo Tiller is infinitely adjustable using the turnbuckle **(15/1)**, independent of the mainframe. The front and rear sets of knives should work at the same depth. On light soils it is advisable to raise the front set slightly. Do not travel too fast when using the Turbo Tiller **(12 km/h maximum)**. Adapt the drill speed to the mulch quality. This will also benefit the quality of sowing. Set the working depth (pressure applied) with the cylinder **(15/2)** using the double acting control unit on the tractor.

5.1.2 Mulch disc unit

The working angle of the mulch disc unit is infinitely adjustable using the turnbuckle **(15.1/1)**, independent of the mainframe. The front and rear mulch discs should work at the same depth. On light soils it is advisable to raise the front set slightly. Adapt the drill speed to the quality of mulching. This will also benefit the quality of sowing. Set the working depth (pressure applied) with the cylinder **(15.1/2)** using the double acting control unit on the tractor.

Adjustment of disc offset

Depending on the firmness of the soil it may be necessary to correct the disc offset with a spanner (SW 36) **(17.1/1)**. As delivered, the disc offset is set to position 3 **(17.1/2)**. The offset of front and rear disc sets must be the same. Setting 0 = no offset (disc separation is uniform) Setting 5 = discs are set 130 mm towards each other. The firmer the soil, the greater the offset required.

5.1.3 Tine harrow sections

For secondary cultivation, harrows with Vibra tines or Drag tines may be used.

To set harrowing depth: Use the turnbuckle **(15/1)** and the cylinder **(15/2)** to infinitely adjust the working depth and angle.

5.1.4 Front levelling bar and track eradicators

The springloaded levelling bar levels the soil in front of the harrow tines and break up coarse clods. They are operating independent of the harrowing depth. Fix the levelling bar **(16/1)** in such a way that only a small wall of earth is pushed forwards. The angle of the tine unit is set with plugged pins on the adjusting cylinder **(16/2)**.

If walls of earth are suddenly pushed forward, they can be cleared by pivoting the tine unit out of the way using the hydraulics.

Track eradicators on Vibra tines (16.1): (fixed or sprung) – adjust this to the track width. The depth **(16.1/1)** can be adjusted with a plug. Do not set the loosener too deep. The loosener coulters can be reversed.

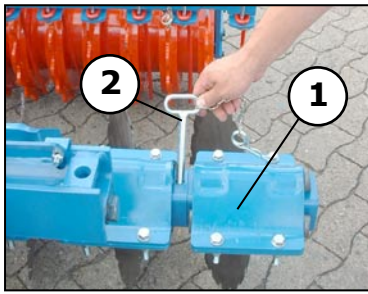

17.2

Mounted unit

Lower the unit until it is about 5 cm from the ground, and bring the front right and rear left **outer disc units (17.2/1)** into the working position. Secure the disc unit with locking pin **(17.2/2)**.

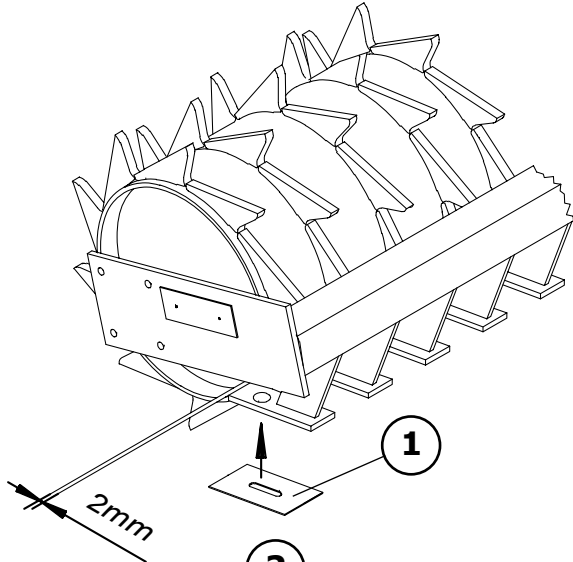

17

5.2 Rollers

5.2.1 Toothed packer roller

Re-adjust the scraper **(17/1)** regularly. Bring the scraper up to the roller until it makes light contact. When tightening up the nuts, ensure that the scraper makes contact along its whole length.

Use scrapers with extra hard coatings (24/1) and fit them so that the coating is upwards relative to the roller casing, and at a **distance of about 2mm from the roller**.

The toothed packer roller can be kept clean by washing and protecting from corrosion each time it is used. If soil dries onto the roller casing, this will slow down the roller.

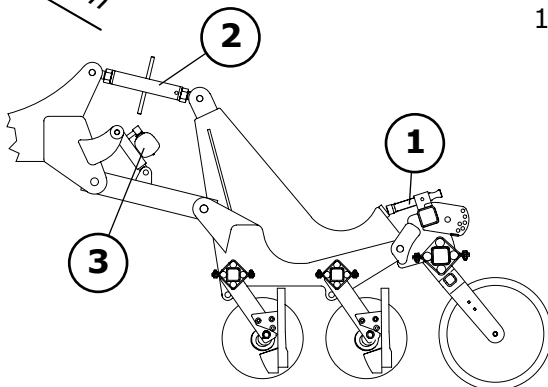

19

5.3 Coulters bar

5.3.1 Setting the coulters pressure

The coulters pressure is effectively fixed. It depends on that portion of the weight of the unit which is transferred to the various knives and rollers. The coulters elements, mounted from a parallelogram, can displace themselves upwards against two cylinders which are under gas pressure. Loading of the coulters bars is carried out once before starting work. The recommended setting is 80 to 100bar. The individual coulters discs are fitted in sprung rubber elements.

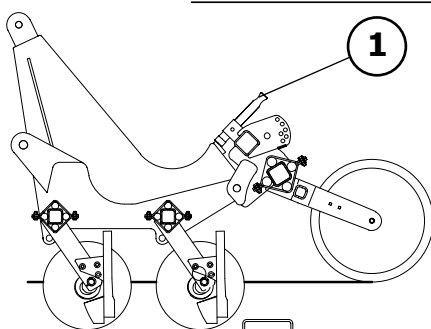

19.1

5.3.2 Setting the sowing depth/press roller

Set the coulters bars horizontally using the turnbuckle **(19/2)**. Set the desired sowing depth using the pressure rollers – adjustment spindle **(19, 19.1)**. If the spindle is shortened, the sowing depth is deeper **(19.1/1)**. If the spindle is lengthened, the sowing depth is shallower **(19/1)**.

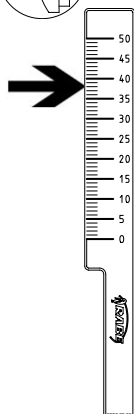

19.2

Ensure that the adjustments on the press rollers are also the same on the foldable extensions!

... for 'normal' sowing depth, set the pressure rollers in the yard on a level platform to the same level as the discs (about 38 on the scale **(19.2)**). If necessary, once working in the field, correct the sowing depth by adjusting the spindle length.

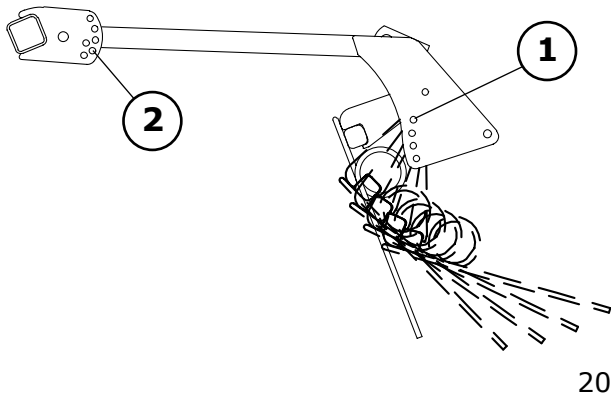

5.4 Rear Harrow

The angle of the rear harrow fitted to the MegaSeed can be adjusted by repositioning the pin in the holed bar **(20/1)**.

The normal setting for the harrow angle should be about 45° on easily friable soil.

- on heavy soils set the tines somewhat steeper.
- If there is a high trash or straw content, set the tines flatter (reduces the danger of blocking).

The pin must always be set below the level of the harrow bracket **(20/1, 2)**. If the harrow is fixed, it cannot move with freedom when the machine is lowered.

The harrow tines should be set vertically for transporting.

(see transport setting)

5.5 Marker arms

The marker arms can be adjusted to the centre line of the tractor. They can be shifted or retracted with a double acting control unit from the tractor.

When using, release the transport safety connectors **(13/1)**. (Keep the connectors on the marker arm)

Set the disc support point correspondingly based on the tractor midline:

For measurements see **(22)**:

a) from the coulter rail **A=half the working width**

b) from the outside coulter

$A1 = \frac{\text{Working width} + \text{row spacing}}{2}$

2

By turning the disc axis **(13/2)**, the disc can be given a greater or lesser degree of grip, according to the soil conditions.

Overload security: Use only a shear bolt of type M 10 x 35 DIN 601 4.6.

When retracting and extending the marker arms, ensure that no-one is in the danger area. Before retracting the tilling equipment into the transport position, the marker arms should be retracted and fixed with connectors **(13/1)**. When retracting, be aware of the transport height (high tension overhead cables).

After the marker arms have been extended, a reciprocal lowering of the marker arms takes place.

After the marker arms have been lowered, the unit must stay in the floating position.

(Only at 3 m of work breadth)

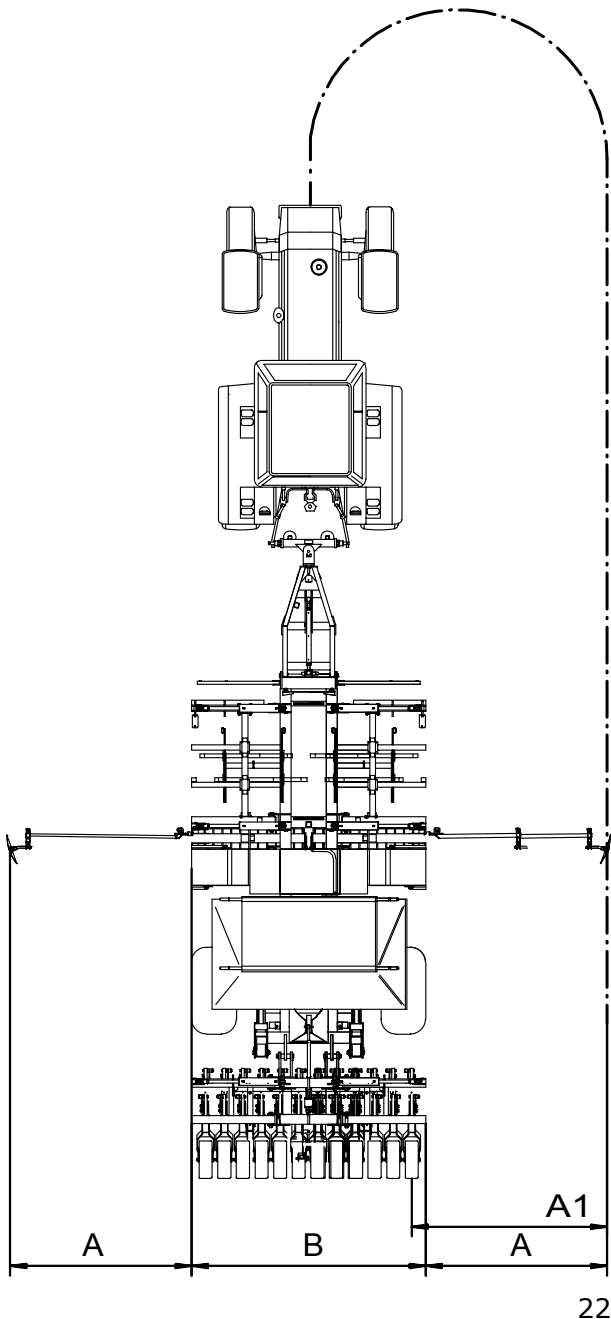

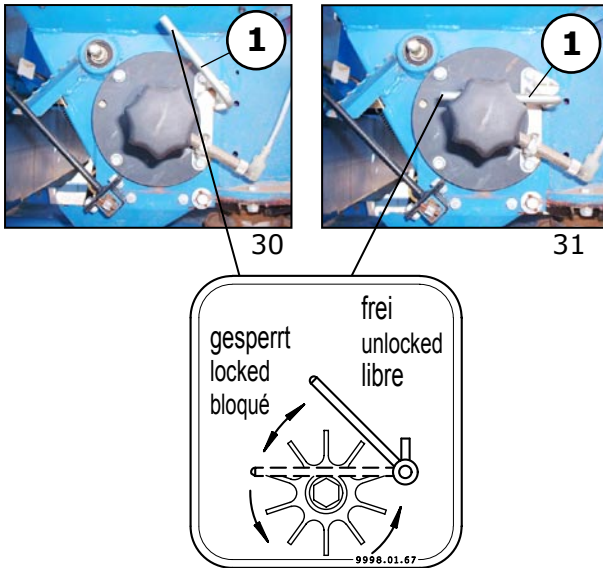

5.6 Sowing and metering

Metering unit

The metering unit is driven by an electronically controlled electric motor. The sowing rate is adjusted by changing the speed of rotation or by setting the metering wheel.

Settings to be borne in mind

1. Metering wheel selection
2. Bottom flap
3. Calibration flap
4. Agitation shaft

1. Metering wheel setting

The metering unit has a large metering wheel **(32/1)** for **coarse seed** and two small metering wheels **(32/2 and 3)** for **fine seed**, as well as three settings **(33)**: Use the star grip **(33/2)** to shift the shaft while turning gently, and then fix with the pin **(33/3)** (bottom flap at setting 1).

- (33)** Position I – Fine metering wheel 1
 Position II – Fine metering wheel 1 and 2
 Position III – Coarse metering wheel

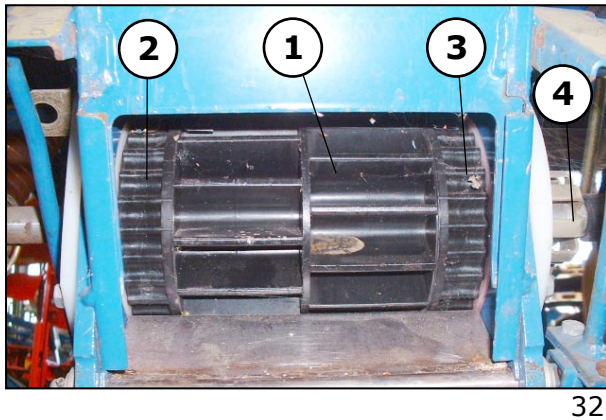

In positions **I** and **II** (fine seed) the coarse metering wheel must be locked with the lever **(31/1)**:

- Lever is set horizontally and engaged at the front **(31/1)** = coarse metering wheel is locked
- Lever is set upwards and engaged **(30/1)** = metering wheel position III. The coarse metering wheel is active and the fine metering wheels are stationary.

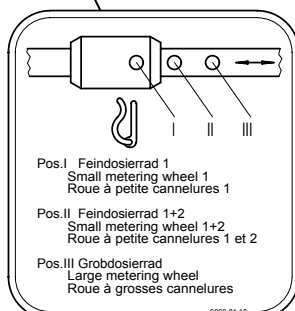
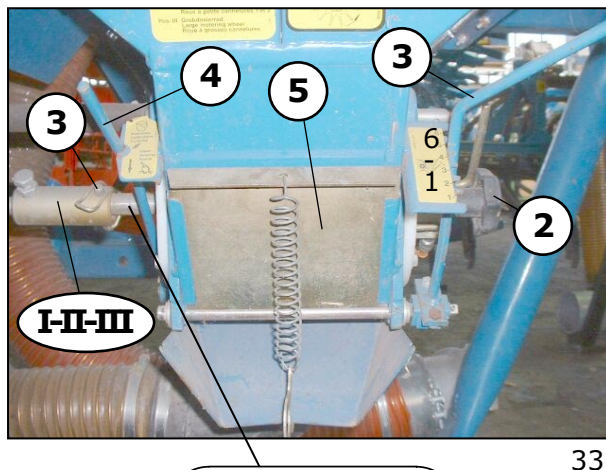

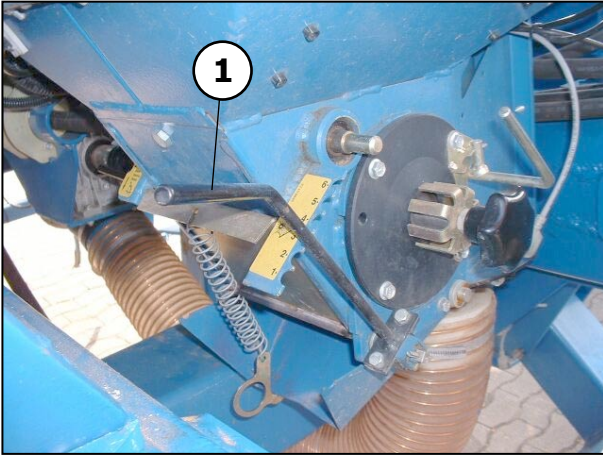

33.1

2. Bottom flap (33.1)

Set the bottom flap with the adjustment lever **(33.1/1)** as per 'Recommended settings for metering'. The bottom flap is below the metering wheels, and closes off the metering housing. It is sprung, and can move out of the way if there are foreign bodies in the seeds. If during calibration it is observed that seeds are breaking, the bottom flap should be opened one stop more than specified in the recommendations.

3. Calibration flap (33.2)

Put the lever **(33.2/1)** in the upper position only for calibration. At this setting the calibration flap is open.

Setting when working = lever downwards

The calibration flap monitoring control shows the driver an error message on the monitor and stops the metering motor if at the start of work (blower running at nominal rate) the calibration flap is still open.

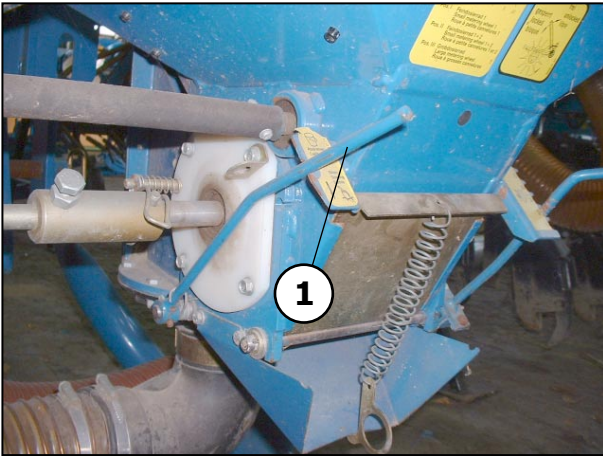

33.2

4. Agitator shafts (33.3)

The agitator shaft **(33.3/1)** ensures that the seed flows evenly.

The clip on the outer agitator fingers should be facing inwards. Remove the agitator fingers **(33.3/2)** from the agitator shaft for rapeseed. This can also be done for freely flowing seeds, such as peas or beans.

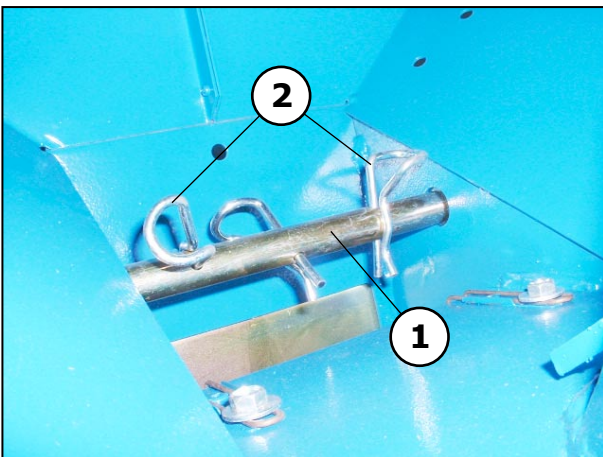

33.3

5.6.1 Calibration

Further information on the calibration procedure is to be found in the description and instructions for use for the Artemis II control.

To ensure a trouble-free current supply, the tractor engine should be running during calibration.

By opening the calibration flap, the metering stop of the monitor device is disabled.



As seeds can behave very differently because of specific weight, grain size, shape, and dressing, it is essential to carry out a calibration test before each change of seed!

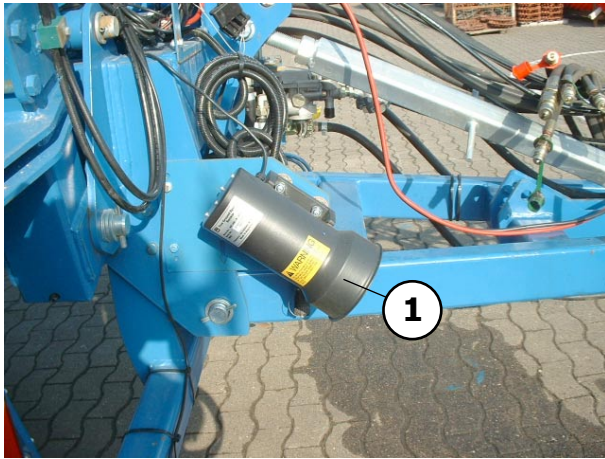

25

5.7 Tramline marking

When laying 'tramlines', the discs of the tramline markers mark the tramline path behind the seed harrow. Switching occurs automatically.

Set the discs to the tramline width, and adjust the grip to suit the soil conditions.

For transport raise and fix the disc booms.

For working, release them from the raised non-working position.

The impulse for electronic forward switching of the tramlines occurs when the machine is raised at the headland.

5.8 Radar

The control of the distance-dependent components is provided by radar. The measurement of distance occurs free of contact. If the rotational speed of the blower is too low, metering does not occur (protection against blockage).

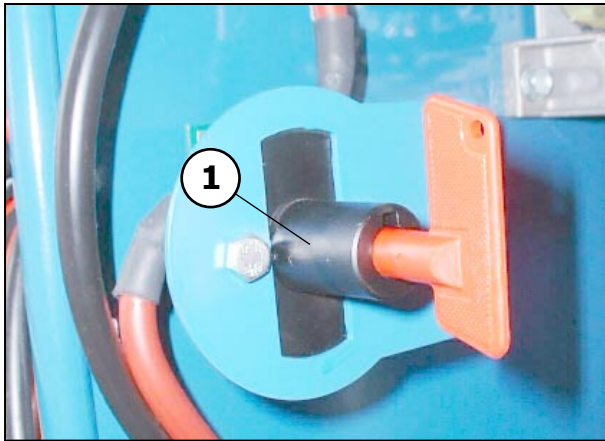

26

5.9 Power supply

Supply current is provided directly by the tractor battery. The supply network including main fuses, main switch (**26/1**), and plug, is firmly mounted on the tractor.

6. Fan speed

A blower speed should be chosen corresponding to the working width and the air supply for the selected seed type.

Fan speeds		
Working width	Fan speed	
	min	max
3m	2200	3000
Greater than 4m	2500	3500

The current fan speed is shown on the computer terminal (34). For the maximum fan speed, an oil volume of about 30 litre/min. is necessary. A hydraulic safety valve (35/2) protects the blower from excessive speed. For running at minimum fan speed, the handwheel (35/1) should be screwed outwards until the desired speed is achieved.

- turning outwards reduces the volume (lower speed)
- turning inwards increases the volume (higher speed)

For running at maximum fan speed, the handwheel should be screwed inwards until the desired speed is achieved. The handwheel should then be fixed in position. The hydraulic fan drive requires an oil cooler on the tractor, as well as a single or double acting control unit with Float position and an unpressurised return with a NW 22 pipe and a size 4 hydraulic coupling. For hydraulic fan drive, the following are required on the tractor:

- with an open hydraulic system, a separate circuit for the hydraulic drive
- a single or double acting control unit with:
 - oil level adjustment and Float position with Load Sensing Control.

- Or with a closed hydraulic system
 - unpressurised return with an NW 22 pipe and a size 4 hydraulic coupling
 - hydraulic oil cooler

If the blower is driven by a double acting control unit, then the control unit must be switchable from the working position directly into the Float position when switching off.

The working pressure is displayed directly on the manometer (35/3).

Working setting	Guideline pressure	
	3m	Greater than 4m
Coarse seed	70 - 90 bar	80 - 100 bar
Fine seed	30 - 40 bar	30 - 50 bar

Attention!

To avoid fluctuations in blower speed where tractors have Load Sensing System, all further loads (coulters pressure setting, marker arms, etc) should be set to the **lowest possible oil quantity** consistent with normal working (adjust on the tractor).

Position 'Lower' = Fan driven Float position = Fan disconnected This will avoid damage to the tractor hydraulic system. If necessary check with tractor manufacturer about running the hydraulic motor continuously.

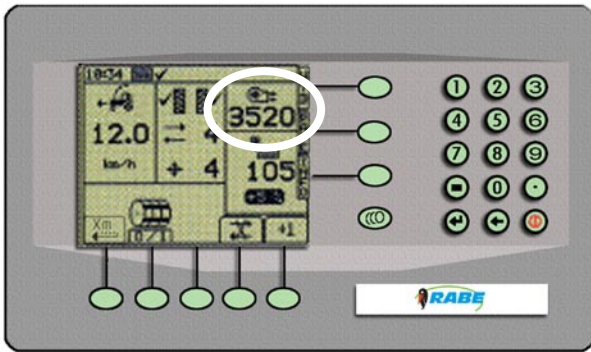

34

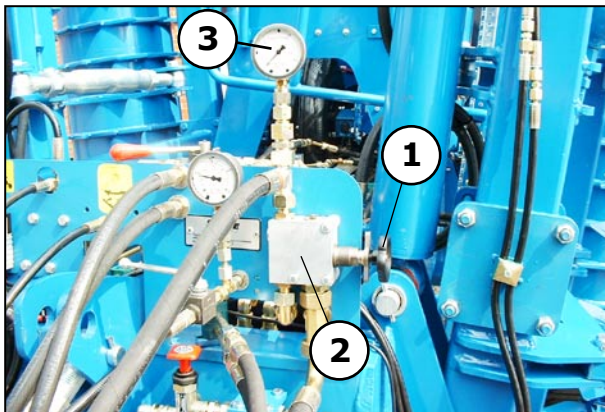

35

7. Seed wheel settings for pneumatic seed drills with hydraulic fan drive

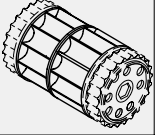
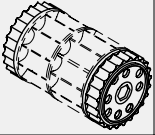
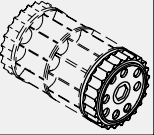
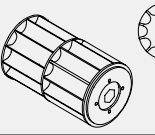
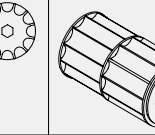
Seed Variety	Seed wheels					Bottom flap position	Fan setting
	Standard seed wheels			Coarse seed wheel (100% filled) Order No. 9001.24.30	Coarse seed wheel (50% filled) Order No. 9001.24.31		
	Coarse seed wheel engaged	2 small seed wheels engaged	1 small seed wheel engaged				
							
Wheat	X			O	O	1	N
Barley	X			O		1	N
Rye	X			O	O	1	N
Triticale	X			O	O	1	N
Oats	X			O	O	1	N
Spelt(Grain)	X			O		1	N
Oilseed rape		X I	O I (<2,5kg/ha)		O I	2	R
Foder rape		O I			X I	2	R
Red clover		O I			X I	1	R
Lucerne	O				X	1	R
Turnips		X I	O I			1	R
Lupins	O I			X I		3	N
Mustard	O I				X I	1	R
Radish	O I				X I	1	R
Phacelia		O			X	1	R
Vetches	X			O		1	N
Grass seed	X (>20kg/ha)	O (<12kg/ha)			O (>10 kg/ha)	1	N/R*
Peas	O I			X I		4	N
Beans	O I			X I		4	N
Flax	O				X	1	N
Linseed					X	1	R
Sunflower		O I			X I	2	N
Soja	O I			X I		3	N

X Standard setting

O Use possible

I without agitating fingers

Fan rpm		
Fan setting	up to 3m	> 3m
Normal (N)	3000	3500
Reduced (R)	2300	2800

* Use the reduced fan drive setting (R) for seed rates below 20 kg/ha. The kg/ha figures are only approximate

7.1 Exchanging metering wheels on pneumatic seed drills



All metering wheel settings must be carried out only when the machine is stopped. Remove plug from mains supply.

1. Free the cleaning springs **(1)** and push upwards (in the empty seed hopper).
2. Disconnect the metering shaft connection from the drive by removing the clip holding the rod **(2)** and the holding pin **(2)** (if present).
3. Remove the fixing screws **(4)** from the bearing cover together with the sensor holder and sensor **(3)**.
4. Remove the entire metering wheel unit and set the bottom flap to position 6.
5. Note the number of packing shims **(7)**.
6. Exchange of metering wheels.
 - Standard metering wheel combination **(8 and 9)**
 - 1 Coarse and 2 fine metering wheels
 - Coarse metering wheel **(10)** (100% filling volume) part number 9001.24.30
 - Coarse metering wheel **(11)** (50% filling volume) part number 9001.24.31
7. Refit the parts in reverse order.
 - Push the desired set of metering wheels onto the metering shaft **(13)**.
8. Limit the sideways play between metering wheel and bearing **(12)** cover to 1mm maximum with shims **(7)** as required.
9. Check that the locking rod **(5)** functions correctly. Only when the small metering wheels are in use should the locking rod be effective.

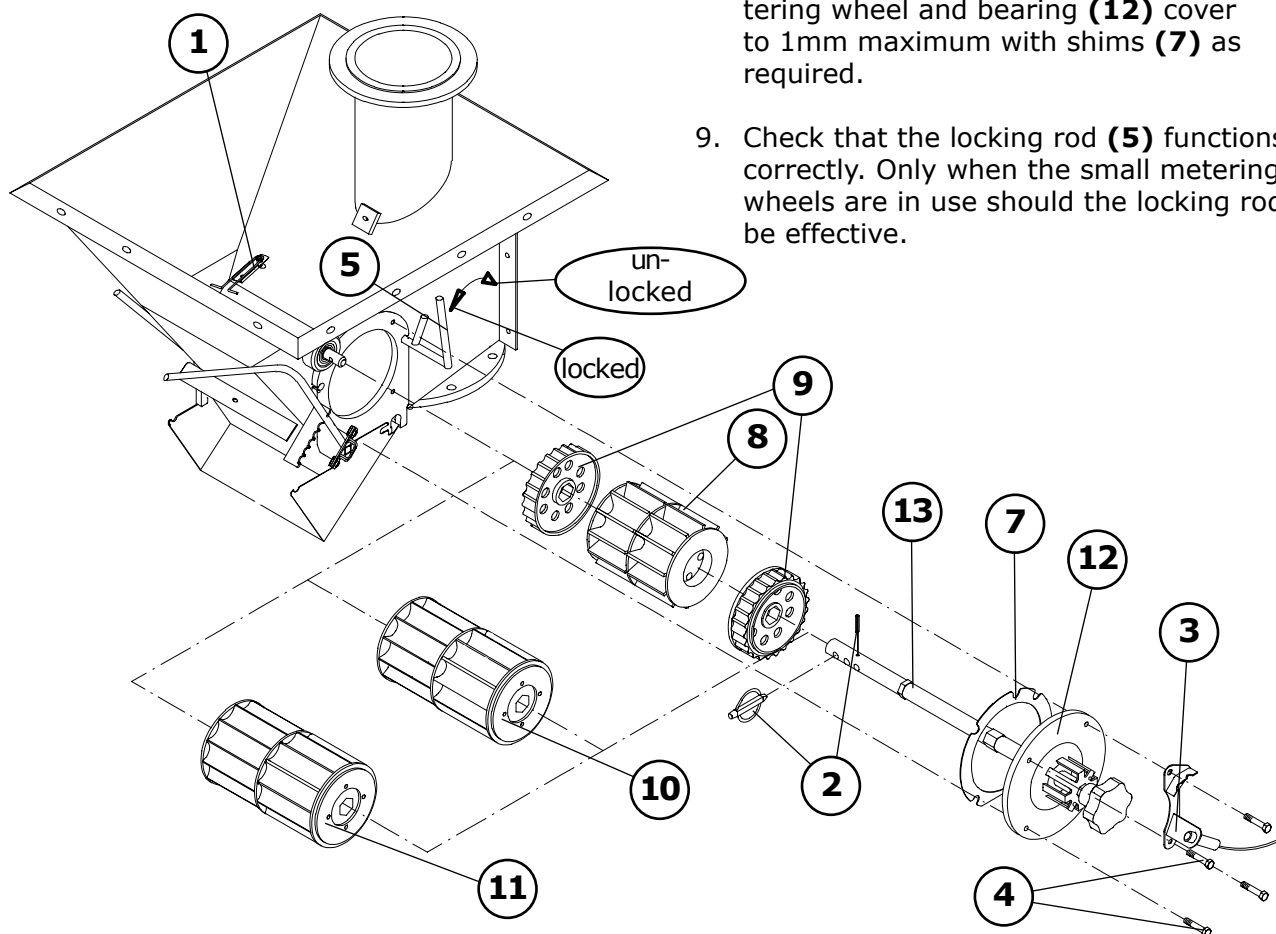

8. Distributor head/tramlining

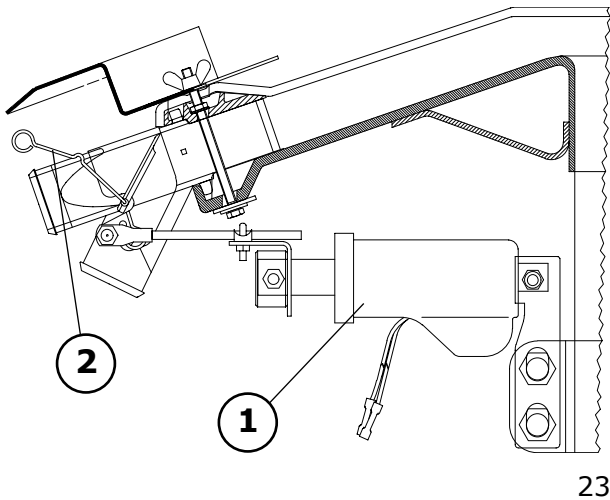

23

The metered seed is dispensed evenly within the distributor head and led through spiral tubes to the coulters.

Make sure that there is a fall in the tubes to the coulters.

If tubes are sagging, shorten them, or reposition them with a fall.

When the tramline is active, the seed is fed back from the affected outlets, **and the metered quantity is automatically reduced by this amount.**

On the tramline outlets, the lower lid lever is connected with the servo-motor by a screwed spring (**23/1**).

The spring length must be set with the thread clamp so that when the tramline is active, the lid lies up against the outlet wall.

The upper lid lever (23/2) (left) must in no circumstances be held fixed on the tramline outlets.

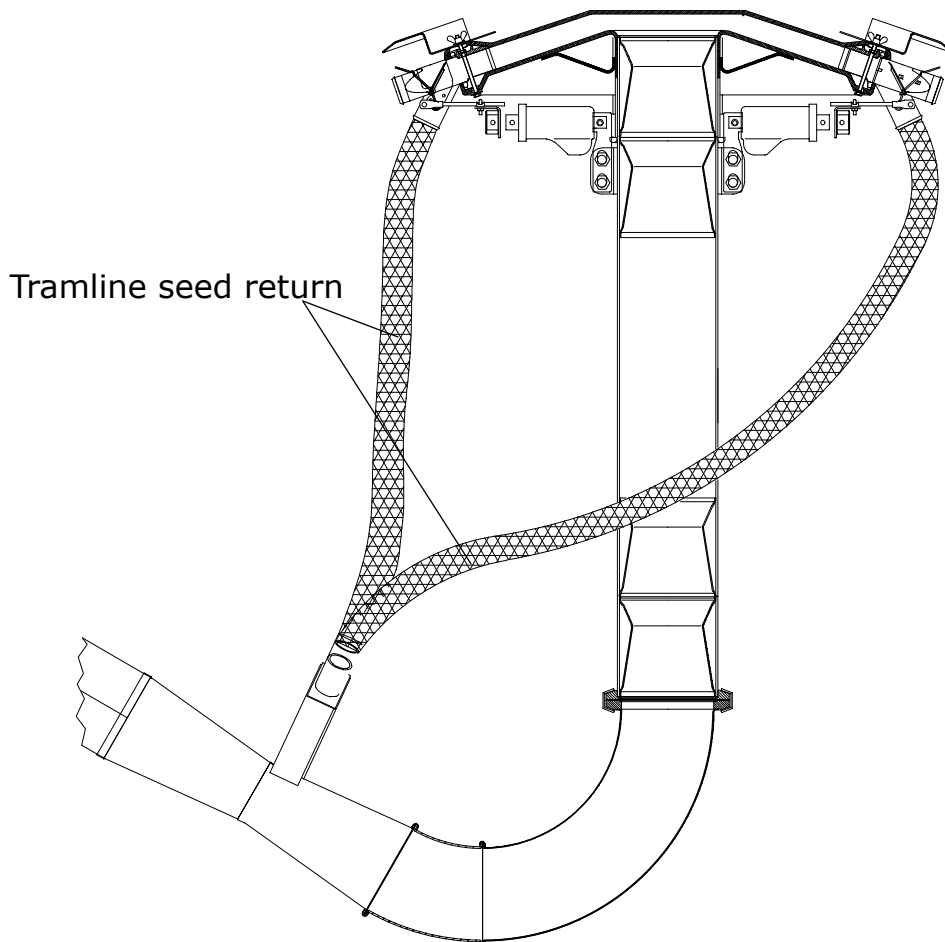

9. Checking sowing precision on seed drills with electrically driven metering wheels

Rule 1

The electrical calibration test and the manual calibration test on the tailwheel should always give the same calibration values (only negligible differences are acceptable).

Rule 2

The setting of the electronic area counter must be based on the working width of the machine.

Rule 3

Undertake the calibration procedure **only** when the tramline is not switched on.

Rule 4

Undertake the calibration procedure **only** when "increased sowing rate" is not active.

Rule 5

Select metering wheel and bottom flap settings which have been recommended.

Rule 6

Use tested scales (household scales). Do not use spring balances or sack scales.

Only by following these rules will the most accurate sowing rates be achieved.

9.1 Tips for use

- Make the drill combination ready for use: track eradicators, tilling tools, undercarriage, ground wheel, markers, tramline system, pre-emergence marking, fan speed/hydraulic motor.
- Check settings (such as calibration test): metering wheel setting (lock coarse metering wheel for fine seeds), bottom flap, agitator shaft (remove agitator fingers for rape-seed), calibration flap, seed quantity setting.
- Switch on the electronics, check tramline rhythm, set cycle position for the first run.
- When starting (even before engaging) run at **1/2** motor speed as a minimum, then maintain constant speed.
- When engaging and starting sowing, the seed requires a certain time to reach the sowing coulters from the metering unit (about 1 sec. for every 2 metres). Remember this after a pause. Therefore raise the unit and set back (see pre-metering).
- **Before sowing, check all coulters for blockages, and re-examine regularly thereafter.**
- Check sowing depth.
- Adjust the travelling speed to the quality of work, so that the seedbed stays even.
- Always keep the control unit for the marker arms in floating position while sowing (see also marker arms).
- When filling the seed hopper, ensure that no foreign bodies (pieces of paper, attachments to sacks) get into the hopper. Keep the hopper lid closed while working. Keep an eye on the seed level in the hopper (Low level warning).
- Because of the hygroscopic nature of seed and dressing, empty the seed hopper and metering unit when laying up the unit for a long period. Beware that dressing is an irritant and is poisonous.

Removal of residues: lower the drill machine, place a vessel under the outlet funnel, open the emptying flap. After emptying, turn all metering wheels a little (**with star grip 33/2**), and with the control, run the blower briefly to remove all residues (to avoid attracting rodents). Leave the emptying flap open.

10. Maintenance

Sensor setting: the inductive sensor is set with a gap of 1 to 3 mm. Set the fan sensor **(39/1)** as follows: turn the fan shaft so that the flat side of the shaft does not face the threaded hole of the sensor. Turn the sensor by hand until it touches the fan shaft, Then turn it three and a half revolutions back, and fix with the nut. A function control (light diode) is built into the sensor, so that in case of a correction or a test circuit, the functioning of the sensor can be seen.

Remove dirt from the drill computer box with a soft cloth and mild household cleaner (do not use solvents). Do **not** dip the housing into liquids.

When carrying out welding on the tractor or the connected unit, and when charging the tractor battery or connecting a second battery (as starting help), always break the connection to the electronics panel.

Because of the hygroscopic nature of seed and dressing, empty the seed hopper and metering unit when laying up the unit for a long period. To completely empty the seed pipes, run the blower briefly.

After cleaning, leave the emptying and calibration flaps open so that no rodents are attracted.

When cleaning, remember that dressing is an irritant, and is poisonous. Protect sensitive body parts such as mucous membranes, eyes, and breathing passages.

Do not let soil dry onto the coulters. Regularly grease bearings which have grease nipples (every 100 hours). Toothed rollers remain clean if they are cleaned and protected from corrosion every time after every use. After cleaning the MegaSeed, and protecting coulters and tracking discs, store it in a dry building. Protect electronic cases and cables from damp, and store in the dry. Seal the plug for the supply cable network (possibly protect from dirt).

Check hydraulic hoses regularly and replace if damaged or perished (see spare parts list). Hoses will age naturally, and should not be used for more than 6 years.

When cleaning, do not aim water jets (especially high pressure) directly at bearings. (The inductive sensors on monitoring equipment should be set at a gap of 1 to 3 mm **(26.1)**. A function control (light diode) is built into the sensor, so that in case of a correction or a test circuit, the functioning of the sensor can be seen. For sensor settings see Maintenance).

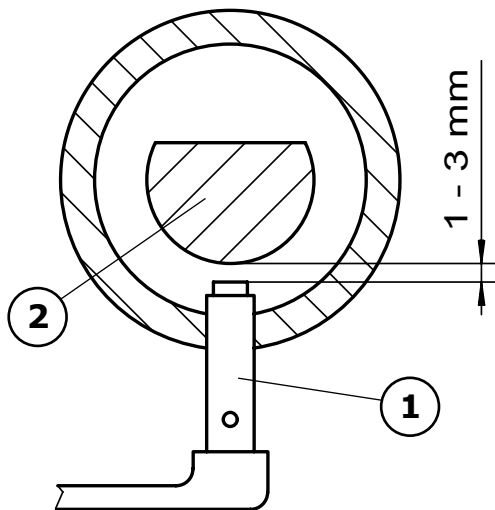

39

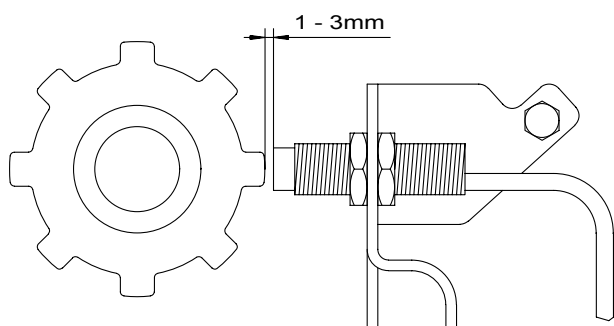

26.1

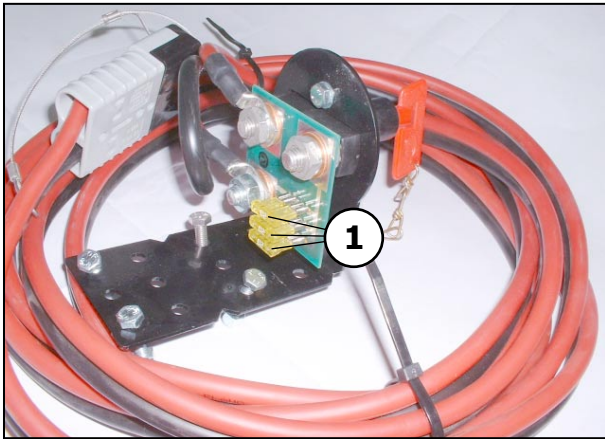

26.2

10.1 Fuses

Fuses – overview		
Location	Designation of fuse	Rabe part number
Supply circuit (26.2/1)	Vehicle flat fuse 20 A	9012.14.34
Tramline (26.3/1)	Vehicle flat fuse 10 A	9012.14.10

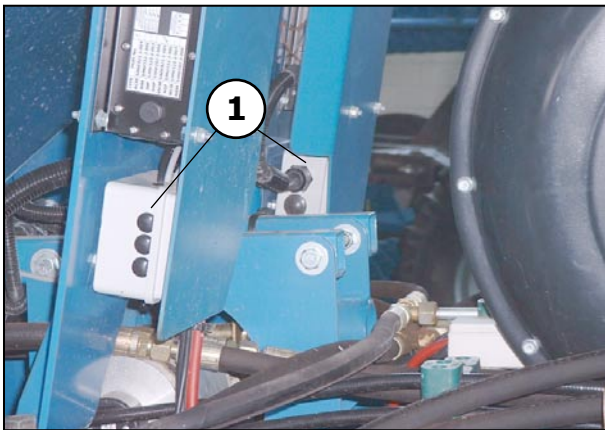

26.3

Residual risk	
Area of danger	Instructions
Folding extensions	Operating instructions
Transport position	Operating instructions
Hydraulic accumulators	Operating instructions – maintenance

10.2 Faults and their resolution

Faults

10.2.1 Electronic faults

1. The electronics do not switch on.
2. The motor for tramline switching is inactive.
3. The metering shaft monitoring does not work.
4. Tramline does not switch forward.
5. Metering motor permanently runs at full speed when the electronics are switched on.
6. Machine can be calibrated electronically but does not start drilling.

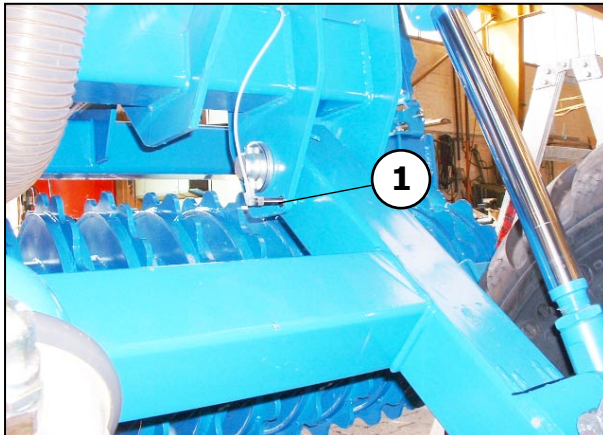

40

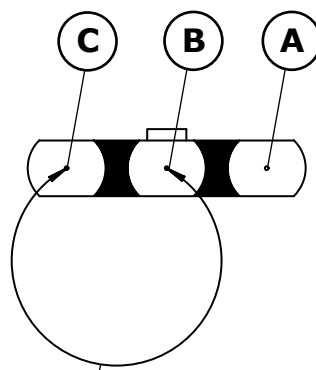

bridging wire

41

Resolution

Check the main fuses (vehicle flat fuses **26.2/1**) in the supply cable network. Check whether supply plug is correctly inserted. Check main switch.

Check 10A fuse in the distribution plug **(26.2/1)**.

Check the functioning of the sensor and its distance from the contact cage **(26.1)**. If necessary set the contact cages to a warning response delay of 20 sec.

Check that the sensor is correctly seated in the undercarriage **(40/1)**.

The machine framework is under a voltage of +12V. Switch off the electronics.

Fault (short circuit or contact fault) within the connection between the rotation pulse generator and the electronic circuits.

- check contact points
- check for broken cables
- check connection clips for contact and tight fit

Rotation pulse generator (on tailwheel) is faulty.

- replace rotation pulse generator

It is possible to check whether the fault is due to faulty current supply to the rotation pulse generator, or whether this is itself faulty as follows:

Checking whether pulse generator on tail wheel is faulty:

- break the connection to the driver rocker arm

With the calibration flap open and the blower stopped, bridge pin 1 and pin 2 on and off (imitate impulses). See adjacent photograph. The metering motor should turn slowly.

The metering motor should turn slowly.

If this happens, the pulse generator is very probably faulty.

- C. -0V (blue)
- B. signal (green/yellow)
- A. +12V (brown)

Faults and their resolution

Faults

10.2.2 Mechanical faults

1. Sowing stops for a row

- a) individual tubes blocked due to blockage in couler.
- b) individual tubes blocked due to poor tube positioning (sagging)
- c) insufficient air supply
- d) Blockage in distributor head due to foreign bodies
- e) Pattern of tramline switching motor is set falsely

2. Marker arm function does not change

- a) Change valve **(41/1)** is dirty.
- b) Change mechanism affected by ingress of air into hydraulic system.
- c) Change valve is faulty.

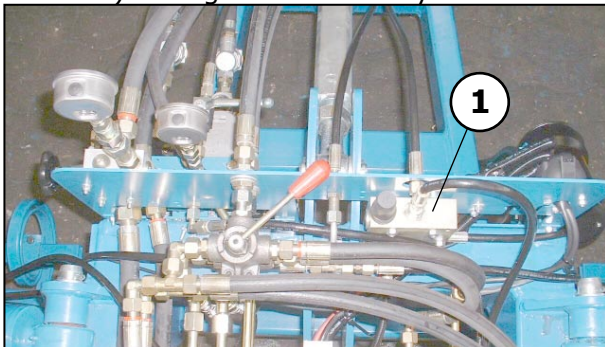

42

3. Counting rhythm of tramline switching functions irregularly or not at all.

- a) Hydraulic pressure switch on change valve set wrongly, or wrong sensor setting on undercarriage.
- b) Poor hydraulic connection on tractor
- c) Incorrectly use of hydr. controls on tractor

Resolution

Remove blockages.

Set tubes with a fall or shorten slightly to ensure regular flow.

Ensure sufficient air supply (adhere to nominal blower speed from at the start of sowing onwards)

Remove foreign bodies.

Check pattern (adjustment)

a) Blow through and clean change valve with compressed air.

b) Bleed air from hydraulics by releasing connections on the cylinders.

c) Replace change valve

See also Electronic faults

Reset the pressure switch on the change valve.

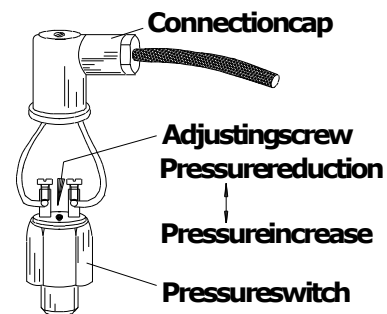

Replace hydraulic couplings on tractor

Allow hydr. control unit time enough to warm up to build up pressure for switching

Faults

Resolution

5. Shear bolts on marker arms shear frequently because

- a) Grip on marker discs is too strong.
- b) The marker arms are used when in the blocked position

6. Tramline switching functions irregularly or not at all

- a) Tramline motor does not pull.
- b) Lever mechanism on distributor outlet is faulty.

7. Desired output rate is not achieved.

- a) Through faulty calibration.
- b) Because of stuck or blocked sowing wheels
- c) Blocked sieve. **(43/1)**
- d) Seeds stick together because they are dirty or sticky.

Reset marker discs

Only use marker arms in the floating position.

See also Electronic faults

Check rhythm. Check functioning of the motor. Check power supply.

Renew distributor outlet.

See directions in the operating instructions and description.

Clean metering wheels. For fine seeds, check wear on the cleaning springs in the metering housing. Replace cleaning springs.

Clean sieve. For spelt, work without a sieve.

Use seeds which are in good condition.

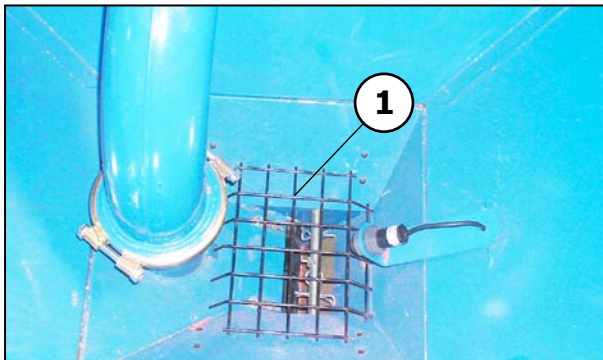

43

11. Transport precautions

Put the unit into the transport position. Check that it is suitable to be transported. Travelling on the unit and staying within its area of danger are forbidden. Towed units weighing more than 3 t require a traffic permit. If the axle load is greater than 3 t, they must have a braking system.



Depending on the traffic permit, maximum speed is either 25 km/h or 40 km/h.

Adapt transport speed to the conditions of the highway.

Take care on slopes and in curves. Take the centre of gravity into account.

Observe the requirements of the road traffic regulations. These make the user responsible for the tractor and trailer being connected together in a way that is safe to traffic when travelling on public highways.



Working equipment must not impede the safe movement of the combination. The connected unit must not cause the permitted tractor axle load, overall weight, and the load bearing capacity of the tyres (depending on speed and air pressure) to be exceeded. To ensure steering safety, the front axle loading must be at least 20% of the unladen vehicle weight.



The maximum permitted width for transport is 3m. The overall length of the combination may be 18m maximum.

If the maximum permitted dimensions are exceeded, a special permit must be obtained. To avoid danger to traffic, no part must project from the outline of the vehicle more than is absolutely necessary. If it cannot be avoided that parts project, they should be covered and made conspicuous. Safety measures must also be taken to make the outermost contours of the unit conspicuous, and to ensure safety at the rear. For example, fit red/white striped warning shields (423 x 423mm, stripes 100mm width at an angle of 45° running outwards and downwards).



Towed or saddle units should be fitted with red rear reflectors, and yellow reflectors at the side when being moved, as well as having their lights illuminated, even during the day (as well as clearance lights when the unit projects more than 400mm beyond the tractor lights).

The safety coverings required for transport in traffic on public highways are available from RABE.

The safety information (TÜV) required for a traffic permit can also be obtained from RABE.

When transporting on public roads in Poland, fit the warning triangle **(40/1)** centred on the unit.

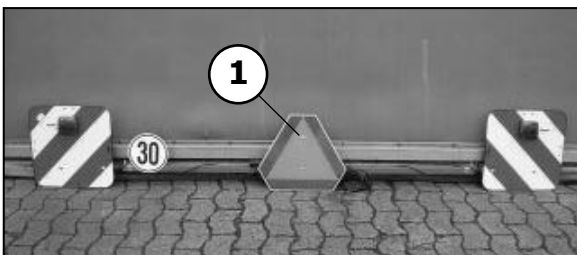

40

12. Positioning of warning symbols on the unit

