



Operating instructions

Seed drill monitor

Multitronic II for

Turbodrill L / XL ... A

Turbodrill XL Combi-Speed ... A



Multitronic II – Seed drill monitor for TURBODRILL

Contents	Page
1) General information	1
2) Operating features of the seed drill monitor	2
2.1) Electrical connection	2
2.2) Technical data	2
2.3) Operating functions	2
3) Starting the seed drill monitor for the first time	3
4) Quick startup instructions for the TURBODRILL	3
4.1) Control panel of the Multitronic II seed drill monitor	3
4.2) Readout pushbuttons	3
4.3) Alarm functions	3
4.4) Main menu (quick guide)	4
5) Multitronic II main menu for TURBODRILL	5
5.1) Default settings	5
5.1.1) Tramline rhythm	5
5.1.2) Operating width	5
5.1.3) Calibration of the hectare meter or entry of wheel impulses	5
5.1.3.1) Calibration of the hectare meter	5
5.1.3.2) Entry of wheel impulses	6
5.1.4) Sowing shaft monitoring	6
5.1.5) Hopper level monitoring	6
5.1.6) Delay time	7
5.1.7) Fan unit monitoring	7
5.1.8) Number of distributor head outlets	7
5.1.9) Number of seed coulters	8
5.1.10) Saving the machine settings	8
5.2) Sensor test	9
5.3) Calibration assistance	10
6) Display (readout) pushbuttons	10
6.1) Hectare meter	10
6.1.1) Partial / total surface area counter display	10
6.1.2) Partial hectare meter reset	11
6.1.3) Partial surface area and total hectare meter reset	11
6.2) Drive speed display	11
6.3) Sowing shaft turning speed display	11
6.4) Fan unit turning speed display	11
6.5) Tramline cycle	11
6.5.1) Tramline cycle display / adjustment	11
6.5.2) Automatic relaying interruption	11
7) Alarm functions	12
7.1) Sowing shaft alarm	12
7.2) Hopper level alarm	12
7.3) Fan unit alarm	13
8) Configuring for machine type and local language	13

1) General information

In order to avoid operating and adjustment errors, please read the following references and explanations thoroughly before operating the unit.

2) Operating features of the seed drill monitor

2.1) Electrical connection

Power is supplied to the seed drill monitor from the tractor's 12V electrical system via a DIN 9680 plug connection. These three-pin plugs also exist in two-pin format, as only the two main terminals (+12V, earth) are required here.

On request, the seed drill monitor can also be fitted to operate via an ISO 11786 signal socket.

2.2) Technical data

Operating voltage: +10V+15V

Power consumption of the seed drill monitor 70 mA

Operating temperature range: -5°C +60°C

Storage temperature -25°C +60°C

Protection rating IP65

Fuse 6A multi-fuse in power supply plug

The circuit breaker resets itself automatically, once the short circuit has been dealt with and after a delay period of approx. 2 min has passed.

LCD unit: Four-line back-lit display

2.3) Operating functions

The Multitronic II seed drill monitor is a compact on-board computer, which carries out a number of useful functions. It helps run important control and monitoring functions, providing practical display and system utility functions designed to simplify operation and save work.

The monitor is designed as a highly versatile unit, suitable for trouble-free application throughout both the "MULTIDRILL ME/MEL" range of mechanical seed drill machines and the "TURBODRILL" range of air-operated units.

There now follows a brief overview of these operating functions:

Control functions:

- Tramline setup
- Additional tramline marking setup
- Automatic or manual relaying of tramline cycles
- Interruption of automatic relaying of tramline cycles driving in order to drive around obstacles

Display functions:

- Tramline cycle and tramline rhythm display
- Partial surface area hectare meter
- Total surface area hectare meter
- Drive speed
- Sowing shaft revolutions
- Fan unit turning speed

Monitoring functions:

- Sowing shaft monitoring
- Hopper level monitoring
- Fan unit monitoring

System utility functions:

- Sensor test
- Calibration assistance for calculation and inclusion of crank handle revolutions
- Calibration of hectare meter (adaptation of hectare meter to ground conditions)
- Adjustable time delay for automatic relaying of tramline cycle
- Menu language selection in English, German or French

turb

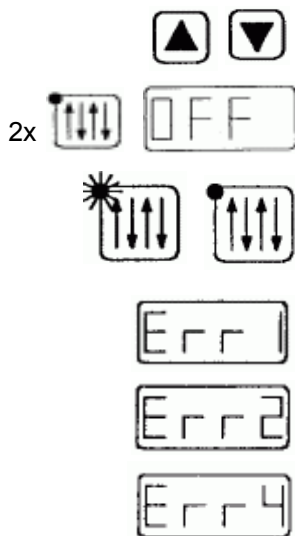
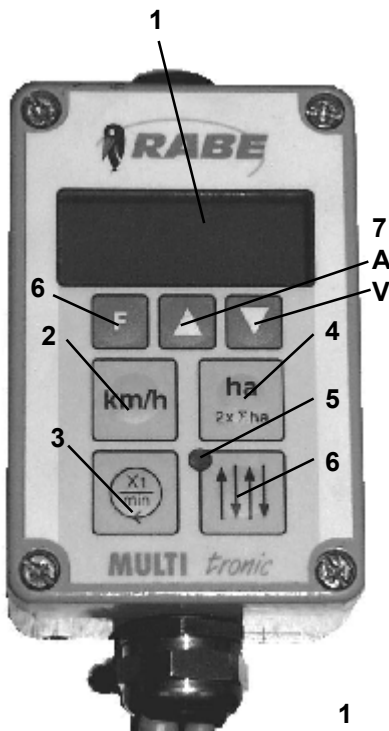

3) Starting the seed drill monitor for the first time

The Multitronic II seed drill monitor is activated by inserting the power supply plug in the socket. A short horn signal indicates that the unit is active. The display is then active for about two seconds, to show the type of machine in use: <E-EL> for the MULTIDRILL ME/MEL range of units or <turb> for the TURBODRILL range of units.

Displays can now be activated for drive speed, hectare meter, sowing shaft revolutions or tramline circuit.

<E-EL> should be displayed for the MULTIDRILL range.

<turb> should be displayed for the **TURBODRILL** range.

If the wrong type of machine is displayed, the unit must be readjusted according to machine type (see sect. 8) before the seed drill monitor can operate correctly.

4) Multitronic II quick startup instructions for the TURBODRILL

4.1) Control panel of the Multitronic II seed drill monitor

Readout/Display (1/1), Function key Drive speed (1/2), Sowing shaft revolutions (1/3) Hectare meter (1/4), LED (1/5), Tramline (1/6) and fan unit turning speed (1/3), Arrow keys (1/7, A,V) and F-key (1/7)

4.2) Readout pushbuttons

The green keys are readout pushbuttons

Drive speed indicator (1/2)

Push once to readout drive speed

Readout Hectare meter (1/4)

Push once to display partial surface area hectare meter

Push twice to display total surface area hectare meter

To reset the partial surface area hectare meter, press both arrow keys **A** and **V** for 2 sec.

To reset both hectare meters, press the two arrow keys **A** and **V** for 10 sec.

Display Turnings (1/3)

Press once to display sowing shaft revolutions

Press twice to display fan unit turning speed

Tramline cycle and Tramline rhythm indicator (1/6)

Use the arrow keys **A** or **V** to alter the tramline cycle manually.

Press twice to switch <OFF>

LED (1/5) ON = tramline active

LED (1/5) OFF = tramline inactive

4.3) Alarm messages

<Err1> = Sowing shaft monitoring alarm

<Err2> = Hopper level monitoring alarm

<Err4> = Fan unit monitoring alarm

4.4) Main menu

Press the **F** function key to activate the main menu.

The seed drill unit is now running with its default settings <AdJU>. This operation also activates the system utility functions sensor test <SEns> and calibration assistance <CAL>.

Quick guide Multitronic II TURBODRILL

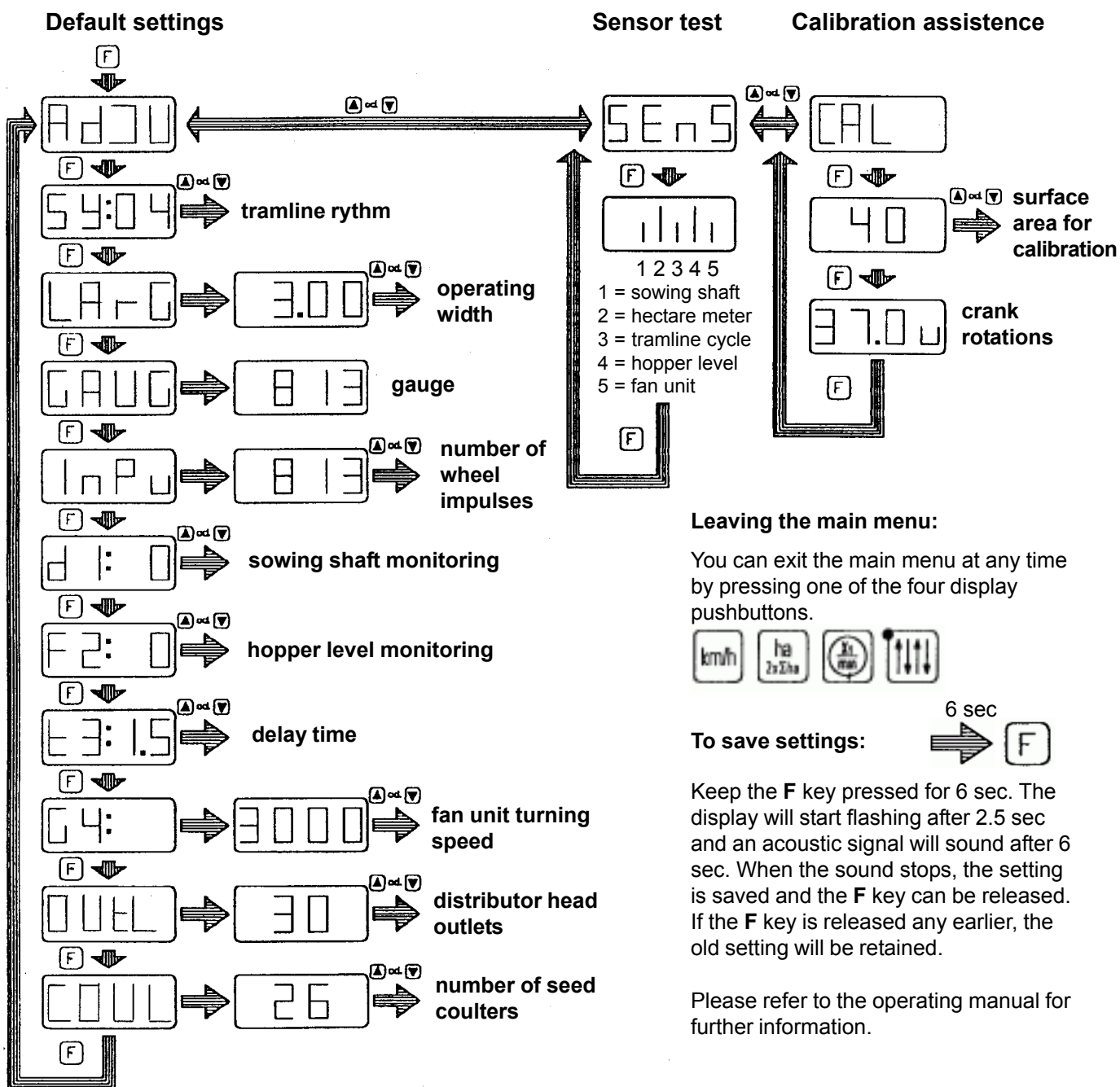

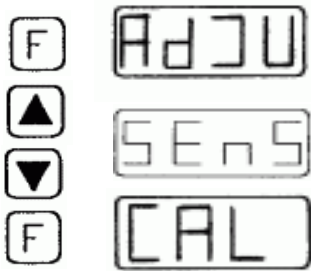

5) Multitronic II main menu for TURBODRILL

Three different functions can be activated via this menu:

- Seed drill unit default settings <AdJU>
- Sensor test <SEnS>
- Calibration assistance <CAL>

Press the **F** key and use arrow key **A** or **V** to select the desired function. Press the **F** key again to activate the selected function.

5.1) Default settings

The default settings must be established before the seed drill monitor can be used for the first time. This operation allows the seed drill monitor to receive data on the configuration of the seed drill unit.

Erroneous default settings lead to functioning errors and incorrectly calculated readouts.

Press the **F** key and use **A** or **V** to select the default setting. Press the **F** key again to activate the default setting.

This operation displays the tramline rhythm setting.

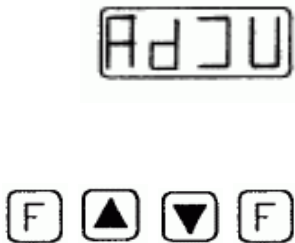

5.1.1) Tramline rhythm

This menu allows adjustment of the symmetric and asymmetric tramline rhythms, or deactivation of the tramline circuit.

Symmetric tramline rhythms:

<SY:02>, 03, 04, 05, 06, 07, 08, 09, 10, 11, 12

Asymmetric tramline rhythms:

<AS:02>, 04, 06, 08, 10, 12

Deactivated tramline circuit: <FG:00>

Use **A** or **V** to select the tramline rhythm and press **F** to save. (See sect. 5.1.10)

The next stage is adjustment of the seed drill unit operating width

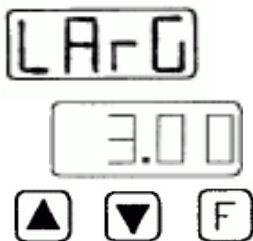

5.1.2) Operating width

The operating width symbol <LArG> is now displayed and, after three seconds, the previously set operating width.

Use **A** or **V** to select the operating width and press **F** to save. (See sect. 5.1.10)

The following stage is hectare meter calibration.

5.1.3) Calibration of the hectare meter or entry of wheel impulses

An impulse count for an operating length of 100 m is required for accurate hectare metering and correct drive speed display.

This can be determined in two different ways:

Entry of wheel impulses using the table

Or by taking an actual reading of the number of impulses

The table value should always be entered first. Calibration of the hectare meter should only be carried out if the unit is giving inaccurate readings.

5.1.3.1) Calibration of the hectare meter

Calibration of the hectare meter involves adapting it to the ground conditions of the land being cultivated. This operation should only be carried out if the unit is giving inaccurate readings.

Calibration is carried out directly in the field.

The calibration symbol <GAUG> will appear first, followed after 3 seconds by the previously set wheel impulse count.



Stop calibration:

If you need to stop the calibration procedure, or carry it out later, briefly press the **F** key. The program will then jump directly to the next adjustment setting menu, wheel impulses <InPu>.

Calibrating the unit:

Proceed as follows if calibration is required:

Drive the machine to the beginning of the field test section.

Measure out a 100 m stretch of field

Press arrow key **A** to display a zero

Drive along the test section. The seed drill monitor will now total up the number of hectare meter impulses.

After reaching the end of the test section, press arrow key **V** and the seed drill monitor will stop recording the number of impulses.

Press the **F** key to save the impulse reading. (See sect. 5.1.10)

The program will now move on to the next adjustment setting menu: wheel impulses <InPu>.

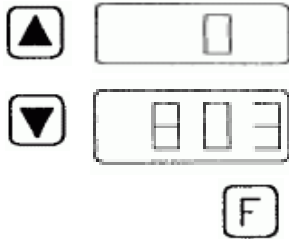

5.1.3.2) Entry of wheel impulses

The wheel impulse symbol <InPu> will be displayed first, followed after 3 sec by the previously set impulse count.

In the case of the TURBODRILL, impulse count depends on operating width:

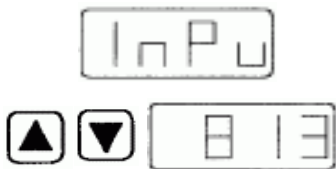

TURBODRILL	Impulse count / 100m
3 m	813
4 m	1084
4,5 m	1220
5 m	1355
6 m	1626

Use arrow key **A** or **V** to select impulse count and press the **F** key to save. (See sect. 5.1.10)

The following step is sowing shaft monitoring adjustment.

5.1.4) Sowing shaft monitoring

Sowing shaft monitoring is enabled or disabled in this menu.

Sowing shaft monitoring on = <d1: 1>

Sowing shaft monitoring off = <d1: 0>

Use arrow key **A** or **V** to enable or disable the monitoring function and press the **F** key to save. (See sect. 5.1.10)

The following step is hopper level monitoring adjustment.

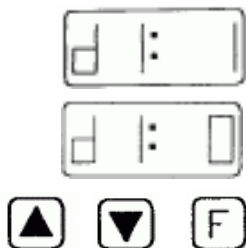

5.1.5) Hopper level monitoring

This menu is used to enable or disable hopper level monitoring.

Hopper level monitoring on = <F2: 1>

Hopper level monitoring off = <F2: 0>

Use arrow key **A** or **V** to enable or disable the monitoring function and press the **F** key to save. (See sect. 5.1.10)

The following step is delay time adjustment.

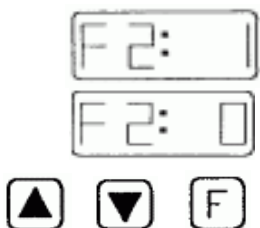

5.1.6) Delay time

Delay time **t3** (t=time) involves delaying the switching impulses for automatic relaying of the tramline cycles. The purpose of this function is to avoid incorrect activation. Delay time is adjustable between 0.5 sec and 7.0 sec, steps of 0.5 sec.

The following values should be entered before operating the unit.

Automatic relaying via:	Display readout (= delay time in sec)
Automatic marker arm sensor	1.5
Shuttle valve pressure switch	1.5
Fendt signal plug socket	1.5
Ground wheel sensor	4.0

Other values can also be entered however. Use arrow keys **A** or **V** to select delay time and press the **F** key to save. (See sect. 5.1.10)

The following step is fan unit monitoring adjustment.

5.1.7) Fan unit monitoring

This menu is used to enable or disable the fan unit monitoring function. The symbol **<G4>** is displayed first, followed after 3 sec by the previously set fan unit turning speed.

When activating fan unit monitoring, there are 3 different fan unit turning speeds to take into account: 2300, 3000 or 3500 rpm.

The following table shows the speed that needs to be entered for each operation.

Machine type	Drive system	Metering	Turning-speed
XL300A	V-belt	Coarse-grain seed	3000
		Fine-grain seed	3000
	Hydraulic motor	Coarse-grain seed	3000
		Fine-grain seed	2300
XL400A – XL600A	V-belt	Coarse-grain seed	3500
		Fine-grain seed	3500
	Hydraulic motor	Coarse-grain seed	3500
		Fine-grain seed	2300

Use arrow keys **A** or **V** to select a fan unit turning speed from the table and press the **F** key to save. (See sect. 5.1.10).

To disable fan unit monitoring, use arrow keys **A** or **V** to select a fan unit turning speed of **<0>** and press the **F** key to save. (See sect. 5.1.10).

The following stage is adjustment of the number of distributor head outlets.

5.1.8) Number of distributor head outlets

The number of distributor head outlets is entered using this menu. This data is necessary for the correct operation of the calibration assistance function.

The symbol for the number or distributor head outlets **<OutL>** appears first, followed after 3 sec by the previously set number. An outlet count of 20, 24, 30, 40, 48 or 60 units can be selected.

Use arrow keys **A** or **V** to select the number of distributor head outlets and press the **F** key to save. (See sect. 5.1.10)

The following stage is adjustment of the number of seed coulters.

E3: 1.5



G4:

2300

3000

3500



0

OutL

30

40



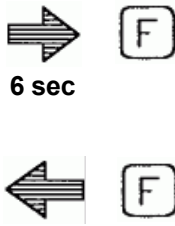
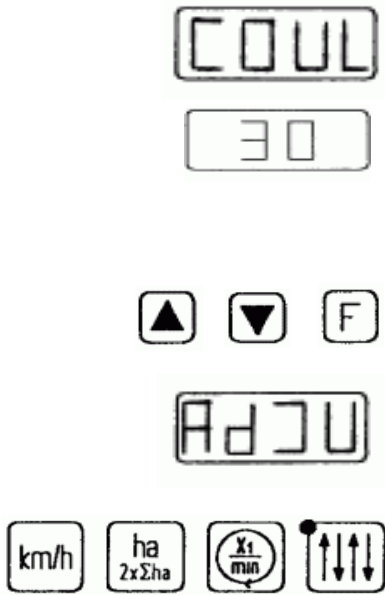

5.1.9) Number of seed coulters

This menu is used to enter the number of seed coulters. This data is necessary for the correct operation of the calibration assistance function.

The seed coulter number symbol <COUL> appears first, followed after 3 seconds by the previously set number.

10 to 60 seed coulters can be selected, but remember that it is not possible to select more seed coulters than there are distributor head outlets.

Seed coulter number from 10 to 20 units: adjustment in single steps.

Seed coulter number from 20 to 60 units: adjustment in double steps.

Used arrow keys **A** or **V** to select seed coulter number and press the **F** key to save. (See sect.5.1.10).

The seed drill unit default adjustment setting procedure is now complete. The program will now return to the main menu and the default setting symbol <AdJU> will be displayed once more.

Press any of the four green display pushbuttons to exit this menu.

5.1.10) Saving the machine settings

If the pre-set default settings are altered, they must be saved to memory.

All settings can be saved in the same way:

Keep the **F** key pressed for 6 sec.

The display will start flashing after 2.5 sec and an acoustic signal will sound after 6 sec.

When the sound stops, the setting is saved.

The **F** key can now be released, giving automatic access to the following menu.

If the **F** key is released early, access is gained to the following menu, but any new setting that may have been entered will be ignored and the previous setting retained.

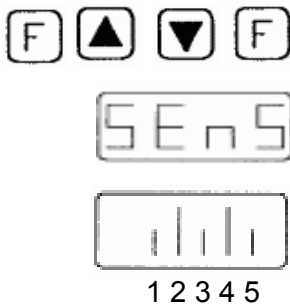

5.2) Sensortest

The sensor test offers a method of testing the function of the seed drill unit sensors.

Press the **F** key and use arrow keys **A** or **V** to select the sensor test function, then press the **F** key again to start the test.

A five-bar display will now appear:

- 1=Sowing shaft monitoring
- 2=Hectare meter
- 3=Tramline cycle relaying
- 4=Hopper level monitoring
- 5=Fan unit monitoring

Each bar shows the activation status of its corresponding control function.

For the hectare meter (Sensor with opening function):

- Long bar = no metal detected
- Short bar = metal detected

Tramline cycle relaying via

Automatic marker arm sensor (sensor with opening function)

- Long bar = no metal detected
- Short bar = metal detected

Shuttle valve pressure switch

- Long bar = Switch under pressure
- Short bar = Switch pressure released

Fendt signal plug socket

- Long bar = lifting gear raised
- Short bar = lifting gear lowered

Ground wheel sensor (sensor with closing function):

- Long bar = metal detected
- Short bar = no metal detected

For hopper level monitoring (limit switch with closing function)

- Long bar = sensor angle vertical (seed hopper full)
- Short bar = sensor angle horizontal (seed hopper empty)

For sowing shaft monitoring without fan module (sensor with opening function)

- Long bar = no metal detected
- Short bar = metal detected

For fan unit monitoring (always with fan unit module)

If the sensor moves up against metal, a long bar is displayed for 0.5 sec and then a short bar once more. If a change occurs in under 0.5 sec, a constant long bar is displayed. If no signal is received, a constant short bar is displayed.

For sowing shaft monitoring with fan unit module

If the sensor moves away from metal, a long bar is displayed for 0.5 sec and then a short bar once more. If a change occurs in under 0.5 sec, a constant long bar is displayed. If no signal is received, a constant short bar is displayed.



You can test the functioning of a sensor by holding a metallic object (e.g. a screwdriver) in front of it and then moving it away again.

Pressure switch functioning, with closed hydraulic circuit, can be tested by raising the marker arms.



When the sensor test is over, press any one of the four green display pushbuttons to leave the menu.

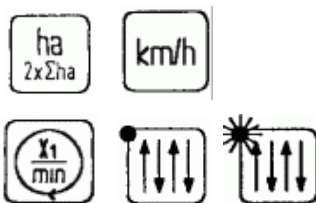
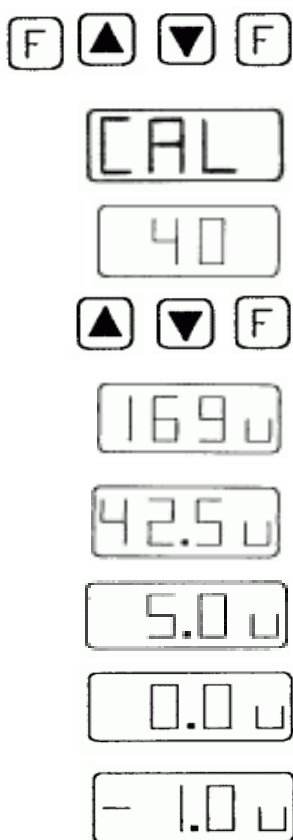

5.3) Calibration assistance

Calibration assistance is a system utility for the seed calibration test. This function computes the number of crank rotations, showing them on the display, and also counts the number of crank rotations during the calibration test.

Press the **F** key and use arrow keys **A** or **V** to select calibration assistance <CAL>. Press the **F** key again to activate the function.

The following choice of surface areas for calibration will now be displayed:

1/10 ha display <10>
 1/20 ha display <20>
 1/40 ha display <40>

Use arrow keys **A** or **V** to select the size of surface area to be calibrated and confirm the selection by a short press on the **F** key.

The seed drill monitor will now compute the number of crank rotations and display the figure. During this operation, values greater than 100 revolutions are displayed as whole figures. Values under 100 revolutions are shown exactly to the nearest half-turn.

The calibration test can now start. The seed drill monitor will now count the number of hand crank rotations, starting from the displayed value and running in reverse, thus providing a constant display of the crank turns that remain to be carried out. The final five turns of the crank are accompanied by an additional acoustic signal, in order to warn the operator of the impending end of the calibration procedure.

Once the value reaches zero <0> a constant acoustic signal is activated to warn the operator to stop calibration immediately.

If calibration does continue, the display will show the corresponding negative value and the constant acoustic signal will continue to be heard until no more impulses are being detected at the hectare meter.

To repeat the calibration test: press the **F** key, the calibration test will restart from the beginning.

To stop the calibration test, press any one of the four green display pushbuttons to leave this menu.

6) Display (readout) pushbuttons

The green keys are the display pushbuttons, which are used to operate the following functions:

- Display / reset hectare meter
- Display drive speed
- Display sowing shaft revolutions
- Display fan unit turning speed
- Display / alter tramline cycle

6.1) Hectare meter

The seed drill monitor operates via two separate hectare meters: namely a partial area meter and a total surface area meter.

Data are displayed as follows, with floating decimal point:

0.00 – 9.99 10.00 – 99.99 100 – 999 1000 – 9995

6.1.1) Partial / total surface area meter display

Press the display key to show the partial surface area count.

Press the display key again and the total surface area count will appear for 5 sec, followed once more by the reading for the partial surface area hectare meter.

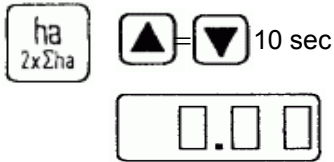
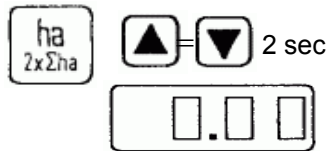

6.1.2) Partial hectare meter reset

Press the display key to show the partial surface area meter. Now press both arrow keys **A** and **V** at the same time and maintain pressed for 2 sec. The display will now start flashing and will reset to zero <0> after a further 2 sec, when it will stop flashing. This completes the reset procedure.

6.1.3) Partial surface area and total hectare meter reset

Press the display key again to show the total hectare meter. Now press both arrow keys **A** and **V** at the same time and maintain pressed for 10 sec. The display will now start flashing and will reset to zero <0> after a further 10 sec, when it will stop flashing. This completes the reset procedure.

6.2) Drive speed display

Press the display key to show drive speed in km/h.

6.3) Sowing shaft revolutions display

Press the display key to show sowing shaft revolutions as a rotating <0>.

6.4) Fan unit turning speed display

Press the display key again to show fan unit turning speed. This reading is shown rounded off to the nearest 100 rpm.

6.5) Tramline cycle

The tramline cycle can be displayed and altered, with tramline cycle relaying being carried out either automatically or manually. It is also possible to interrupt automatic relaying, when avoiding obstacles for example, without altering the tramline cycle itself.

6.5.1) Tramline cycle display / adjustment

Press the display key to show the tramline cycle and rhythm.

Left : **Tramline cycle**

Right : **Tramline rhythm**

Please refer to sect. 5.1.1 for details of tramline rhythm adjustment.

Tramline cycle relaying:

The tramline cycle is automatically relayed by means of sensors or pressure switches, although it can also be activated manually.

Use arrow keys **A** or **V** to alter the tramline cycle

Once a tramline is established, the red LED in the tramline display key will light up.

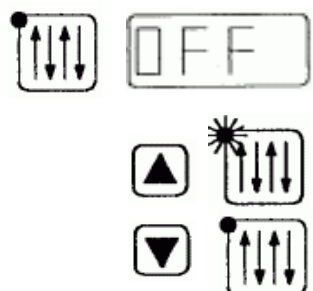
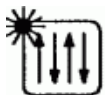
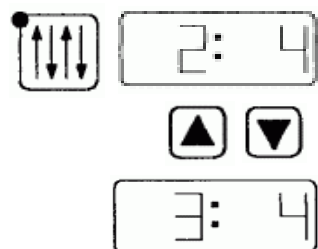

6.5.2) Automatic relaying interruption

Press the display key again to make <OFF> appear. This operation interrupts automatic relaying of the tramline cycle. It is now possible to operate the marker arms or raise the seed drill unit, without relaying the tramline cycle. The tramline can now also be directly activated or deactivated:

Tramline ON: press arrow key **A** (LED lights up)

Tramline OFF: press arrow key **V** (LED goes out)

Press the display key again to return to normal tramline cycle relaying. The tramline cycle that was active before the interruption will now reappear on the display.

7) Alarm functions / messages

Seed hopper level, fan unit turning speed and sowing shaft revolutions can be monitored, on condition that the seed drill unit is fitted with the corresponding activated monitoring device. (See sections 5.1.4 and 5.1.5 for information on activating hopper level and sowing shaft monitoring. For fan unit monitoring, see sect. 5.1.7).

The monitoring systems are only active when the seed drill unit is in operating position (with lowered seed drill unit and/or marker arms).

The monitoring systems are not active when the seed drill unit is in transport position (with raised seed drill unit and/or marker arms).

7.1) Sowing shaft alarm

The sowing shaft monitoring system controls the turning of the sowing shaft. (Please refer to sect. 5.1.4 for information on how to activate sowing shaft monitoring).

A sensor receives impulses from a transmitting device on the sowing shaft. If 10 seconds pass without an impulse being received (with the unit in operating mode), visual and acoustic alarm signals are activated.

Acoustic alarm = intermittent sound

Visual alarm = <Err1>

The alarm can be stopped by pressing one of the green display keys, but will nevertheless be reactivated if the marker arms are operated or the machine is raised.

In the event of a fault occurring that cannot be dealt with immediately (e.g. a faulty sensor), it is possible to disable the monitoring system completely as a temporary measure, until the fault can be rectified. (Please refer to sect. 5.1.4 for details on how to disable sowing shaft monitoring).

7.2) Hopper level alarm

The hopper level monitoring system controls the amount of seed in the hopper. (Refer to sect. 5.1.5 for details of how to activate hopper level monitoring).

The level display receives a sensor signal when the quantity drops to a certain level, activating an acoustic and visual alarm signal.

Acoustic alarm = intermittent sound

Visual alarm = <Err2>

The alarm can be stopped by pressing one of the green display keys, but will nevertheless be reactivated if the marker arms are operated or the machine is raised.

In the event of a fault occurring that cannot be dealt with immediately (e.g. a faulty sensor), it is possible to disable the monitoring system completely as a temporary measure, until the fault can be rectified. (Please refer to sect. 5.1.5 for details on how to disable hopper level monitoring).

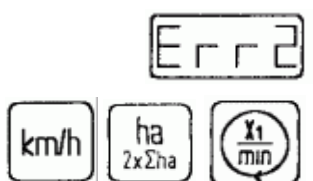
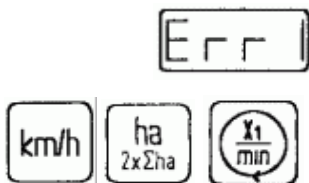

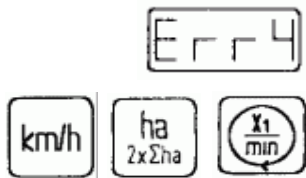

7.3) Fan unit alarm

The fan unit monitoring systems controls the turning speed of the fan unit. (Please refer to sect. 5.1.7 for details on how to activate fan unit monitoring). A sensor receives impulses from the fan unit shaft at a rate of one impulse for each turn of the shaft. The seed drill monitor uses this data to calculate fan unit turning velocity in rpm, and compared this value to the preset target speed. An acoustic and visual alarm is activated whenever the detected speed deviates by more than **500** rpm either way from the preset value.

Acoustic alarm = intermittent sound

Visual alarm = <Err4>

The alarm can be stopped by pressing one of the green display keys, but will nevertheless be reactivated if the marker arms are operated or the machine is raised.

In the event of a fault occurring that cannot be dealt with immediately (e.g. a faulty sensor), it is possible to disable the monitoring system completely as a temporary measure, until the fault can be rectified. (Please refer to sect. 5.1.7 for details on how to disable fan unit monitoring).

8) Configuring for machine type and local language

The Multitronic II seed drill monitor can be operated with both the MULTIDRILL range of mechanical seed drill machines and the TURBODRILL range of air-operated units.

The menus can be configured to appear in English, German or French.

The seed drill monitor is supplied factory-adjusted for the corresponding machine, but the user can change these parameters at any time:

Remove the power supply plug from its socket

With the **F** key pressed, push the plug back into the socket.

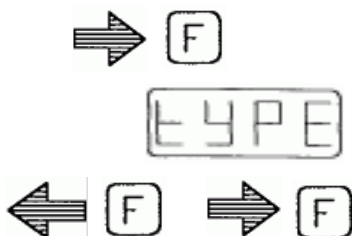

The display will show <tYPE> for the corresponding type of machine

Release the **F** key once more

Press the **F** key again to activate machine type configuration.



Use arrow keys **A** or **V** to select machine type **MULTIDRILL ME/MEL** (display <E-EL>)



and press the **F** key to save. (See sect. 5.1.7)

The display will show <tYPE> once more



Use arrow keys **A** or **V** to activate local language configuration (and to display <nAt>)



Press the **F** key to activate the language selection feature.

Use arrow keys **A** or **V** to select the desired language



English Anzeige <EnGL>

French Anzeige <FrAn>

German Anzeige <EnGL>



Press the **F** key to save the selected language. (See sect. 5.1.7).

The display will show <nAt>once more



Configuration is now complete. Press any one of the green display pushbuttons to leave the menu.